

**AGENDA**  
**REGULAR BOARD MEETING**  
**June 21, 2023**

1. CALL TO ORDER
2. CONSIDER ADOPTION OF AGENDA
3. CLOSED SESSION
4. OPEN SESSION/REPORT ACTION FROM CLOSED SESSION
5. CONSENT CALENDAR
6. STAFF REPORTS
7. REVIEW DISTRICT MEETING DATES/TIMES FOR JULY 2023
8. CORRESPONDENCE
9. *Action Item* CONSIDER ADOPTING ORDINANCE O2023-03 INCREASING WATER, SEWER AND SOLID WASTE SERVICE CHARGES AND STORM DRAINAGE AND SECURITY SPECIAL TAXES
10. *Action Item* CONSIDER ADOPTING RESOLUTION R2023-08 APPROVING THE PROPOSED BUDGET FOR FISCAL YEAR 2023-24, INCLUDING CAPITAL PROJECTS
11. *Action Item* CONSIDER APPROVAL OF DRAFT BOARD RESPONSE TO THE COMMUNITY REGARDING THE 2022-2023 SACRAMENTO COUNTY GRAND JURY REPORT
12. *Action Item* CONSIDER APPROVAL OF THE SAFETY CENTER REPLACEMENT
13. *Action Item* CONSIDER REQUEST FROM KHOV FOR PARTIAL FUNDING ON LIFT STATION 6B
14. *Action Item* CONSIDER ADOPTING CHANGES TO UTILITY WORKER AND OPERATOR JOB DESCRIPTIONS
15. CONSIDER VOTING FOR CSDA ELECTION
16. *Action Item* CONSIDER APPROVAL FOR PURCHASE OF A COMMUNOTOR FOR MAIN LIFT NORTH
17. COMMENTS FROM THE PUBLIC
18. DIRECTOR COMMENTS/SUGGESTIONS
19. ADJOURNMENT (*Motion*)



# RANCHO MURIETA COMMUNITY SERVICES DISTRICT

15160 JACKSON ROAD  
RANCHO MURIETA, CALIFORNIA 95683  
916-354-3700  
FAX – 916-354-2082

## AGENDA

*“Your Independent Local Government Agency Providing  
Water, Wastewater, Drainage, Security, and Solid Waste Services”*

### REGULAR BOARD MEETING

**June 21, 2023**

Closed Session 4:00 p.m./Open Session 5:00 p.m.  
Rancho Murieta, CA 95683

---

#### BOARD MEMBERS

Tim Maybee	President
Martin Pohll	Vice President
Linda Butler	Director
Randy Jenco	Director
Stephen Booth	Director

---

#### STAFF

Mimi Morris	General Manager
Michael Fritschi	Director of Operations
Susan Wren	Interim Director of Administration
Andrew Ramos	District General Counsel
Amelia Wilder	District Secretary
Kelly Benitez	Security Supervisor
Travis Bohannon	Chief Plant Operator

# RANCHO MURIETA COMMUNITY SERVICES DISTRICT

June 21, 2023

## REGULAR BOARD MEETING

Call to Order

Closed Session 4:00 p.m./Open Session 5:00 p.m.

Note that this meeting will be held in-person at the address set forth above, and not via videoconference. In order to comply with the State's COVID-related Guidance for the use of face coverings, it is strongly recommended that all persons, regardless of vaccination status, continue to mask while in indoor public settings and businesses.

All persons present at District meetings will place their cellular devices in silent and/or vibrate mode (no ringing of any kind). During meetings, these devices will be used only for emergency purposes and, if used, the party called/calling will exit the meeting room for conversation. Other electronic and internet enabled devices are to be used in the "silent" mode. Under no circumstances will recording devices or problems associated with them be permitted to interrupt or delay District meetings.

## AGENDA

ESTIMATED RUNNING TIME 5:00

### 1. CALL TO ORDER - Determination of Quorum – President Maybee **(Roll Call)**

### 2. CONSIDER ADOPTION OF AGENDA **(Motion)**

*The Board will discuss items on this agenda, and may take action on those items, including informational items and continued items. No action or discussion will be undertaken on any item not appearing on the agenda, except that (1) directors or staff may briefly respond to statements made or questions posed during public comments on non-agenda items, (2) directors or staff may ask a question for clarification, make a brief announcement, or make a brief report on his or her own activities, (3) a director may request staff to report back to the Board at a subsequent meeting concerning any matter or request staff to place a matter on a future Board meeting agenda, and (4) the Board may add an item to the agenda by a two-thirds vote determining that there is a need to take immediate action and that the need for action came to the District's attention after posting the agenda.*

*The running times listed on this agenda are only estimates and may be discussed earlier or later than shown. At the discretion of the Board, an item may be moved on the agenda and or taken out of order. **TIMED ITEMS** as specifically noted, such as Hearings or Formal Presentations of community-wide interest, will not be taken up earlier than listed.*

### 3. CLOSED SESSION

- A. Conference with legal counsel concerning significant exposure to litigation pursuant to Gov. Code 54956.9(d)(2) and (e)(1) (one case) and potential initiation of litigation pursuant to Gov. Code 54956.9(d)(4) (one case)
- B. Public employee performance evaluation of the General Manager (Gov. Code section 54957).

### 4. OPEN SESSION/REPORT ACTION FROM CLOSED SESSION

**5. CONSENT CALENDAR** (Motion) **(Roll Call Vote)** (5 min.) All items in this agenda item will be approved as one motion if they are not excluded from the motion adopting the consent calendar.

A. Approval of Board Meeting and Committee Meeting Minutes

1. May 17, 2023 Regular Board Meeting Minutes

2. June 7, 2023 Regular Board Meeting Minutes

B. Bills Paid Listing for April and May

C. Discontinuation of Repairs to Lake 11 and Continue the Contracting Emergency Declaration

**6. STAFF REPORTS** (Receive and File)

A. General Manager's Report

B. Administration/Financial Report

C. Security Report

D. Utilities Report

**7. REVIEW DISTRICT MEETING DATES/TIMES FOR JULY 2023**

A. Improvements – July 5, 2023 at 8:00 a.m.

B. Finance – July 5, 2023 at 10:00 a.m.

C. Communications – July 6, 2023 at 8:30 a.m.

D. Security – July 6, 2023 at 10:00 a.m.

E. Regular Board Meeting – July 19, 2023 - Open Session at 5:00 p.m.

**8. CORRESPONDENCE**

A. Email from Janis Eckard

B. Email for Richard Gehrs

**9. Action Item CONSIDER ADOPTING ORDINANCE O2023-03 INCREASING WATER, SEWER AND SOLID WASTE SERVICE CHARGES AND STORM DRAINAGE AND SECURITY SPECIAL TAXES** (Discussion/Action) (Motion) **(Roll Call Vote)**

**10. Action Item CONSIDER ADOPTING RESOLUTION R2023-08 APPROVING THE PROPOSED BUDGET FOR FISCAL YEAR 2023-24, INCLUDING CAPITAL PROJECTS** (Discussion/Action) (Motion) **(Roll Call Vote)**

**11. Action Item CONSIDER APPROVAL OF DRAFT BOARD RESPONSE TO THE COMMUNITY REGARDING THE 2022-2023 SACRAMENTO COUNTY GRAND JURY REPORT** (Discussion/Action) (Motion) **(Roll Call Vote)**

**12. Action Item CONSIDER APPROVAL OF THE SAFETY CENTER REPLACEMENT** (Discussion/Action) (Motion) **(Roll Call Vote)**



**13. Action Item CONSIDER REQUEST FROM KHOV FOR PARTIAL FUNDING ON LIFT STATION 6B** (Discussion/Action) (Motion) **(Roll Call Vote)**

**14. Action Item CONSIDER ADOPTING CHANGES TO UTILITY WORKER AND OPERATOR JOB DESCRIPTIONS** (Discussion/Action) (Motion) **(Roll Call Vote)**

**15. CONSIDER VOTING FOR CSDA ELECTION** (Discussion/Action) (Motion) **(Roll Call Vote)**

**16. Action Item CONSIDER APPROVAL FOR PURCHASE OF A COMMUNOTOR FOR MAIN LIFT NORTH** (Discussion/Action) (Motion) **(Roll Call Vote)**

**17. Action Item CONSIDER ADOPTING RESOLUTION R2023-10 FOR CALPERS 180 DAY WAIT PERIOD EXCEPTION FOR DONNA MCLEOD AS ACCOUNTING TECHNICIAN** (Discussion/Action) (Motion) **(Roll Call Vote)**

## **18. COMMENTS FROM THE PUBLIC**

*Members of the public may comment on any item of interest within the subject matter jurisdiction of the District and any item specifically agendized. Members of the public wishing to address a specific agendized item are encouraged to offer their public comment during consideration of that item. With certain exceptions, the Board may not discuss or take action on items that are not on the agenda. If you wish to address the Board at this time or at the time of an agendized item, as a courtesy, please state your name and address. Speakers presenting individual opinions shall have 3 minutes to speak. Speakers presenting opinions of groups or organizations shall have 5 minutes per group.*

## **19. DIRECTOR COMMENTS/SUGGESTIONS**

*In accordance with Government Code 54954.2(a), directors and staff may make brief announcements or brief reports of their own activities. They may ask questions for clarification, make a referral to staff or take action to have staff place a matter of business on a future agenda.*

## **20. ADJOURNMENT** (Motion)

In accordance with California Government Code Section 54957.5, any writing or document that is a public record, relates to an open session agenda item and is distributed less than 24 hours prior to a special meeting, will be made available for public inspection in the District offices during normal business hours. If, however, the document is not distributed until the regular meeting to which it relates, then the document or writing will be made available to the public at the location of the meeting.

In compliance with federal and state laws concerning disabilities, if you are an individual with a disability and you need a disability-related modification or accommodation to participate in this meeting or need assistance to participate in this meeting, please contact the District Office at 916-354-3700 or awilder@rmcsd.com. Requests must be made as soon as possible.

Note: This agenda is posted pursuant to the provisions of the Government Code commencing at Section 54950. The date of this posting is June 16, 2023. Posting locations are: 1) District Office; 2) Rancho Murieta Post Office; 3) Rancho Murieta Association; 4) Murieta Village Association.



**RANCHO MURIETA COMMUNITY SERVICES DISTRICT  
REGULAR BOARD MEETING MINUTES**

May 17, 2023

Open Session 5:00 p.m.

**1. CALL TO ORDER/ROLL CALL**

President Maybee called the Regular Board Meeting of the Board of Directors of Rancho Murieta Community Services District to order at 4:30 p.m. in the District meeting room, 15160 Jackson Road, Rancho Murieta. Director's present at the District office were Timothy Maybee, Martin Pohll, Randy Jenco, and Linda Butler. Director Stephen Booth was absent. Also present at the District office were Michael Fritschi, Interim General Manager; Travis Bohannon, Interim Director of Operations; Kelly Benitez, Security Supervisor; Andrew Ramos, District General Counsel; and Amelia Wilder, District Secretary.

**2. CONSIDER ADOPTION OF AGENDA**

**Motion/Maybee to adopt the Agenda. Second/Jenco. Roll Call Vote: Ayes: Maybee, Pohll, Jenco, Butler. Noes: None. Absent: Booth: Abstain: None.**

**3. BOARD ADJOURNED TO CLOSED SESSION TO DISCUSS THE FOLLOWING ITEMS:**

- A. *Conference with legal counsel concerning significant exposure to litigation pursuant to Gov. Code 54956.9(d)(2) and (e)(1) (one case) and potential initiation of litigation pursuant to Gov. Code 54956.9(d)(4) (one case)*
- B. *Closed session regarding appointment of the General Manager (Gov. Code, § 54957.)*
- C. *Closed session regarding labor negotiations (Gov. Code, § 54957.6.) District representative(s): Directors Maybee and Pohll. Unrepresented employee: General Manager*

**4. OPEN SESSION/REPORT ACTION FROM CLOSED SESSION**

Director Maybee reported that no decisions were made.

**5. CONSIDER APPOINTMENT OF MELINDA MORRIS AS GENERAL MANAGER AND APPROVAL OF EMPLOYMENT AGREEMENT**

Director Maybee read a statement referring to the proposed agreement located in the Board Packet.

**Motion/Maybee to accept the GM agreement as proposed. Second/Butler. Roll Call Vote: Ayes: Maybee, Pohll, Jenco, Butler. Noes: None. Absent: Booth: Abstain: None.**

**6. CONSENT CALENDAR**

**Motion/Maybee to approve Consent Calendar. Second/Pohll. Roll Call Vote: Ayes: Maybee, Pohll, Jenco, Butler. Noes: None. Absent: Booth. Abstain: None.**

**7. REVIEW DISTRICT MEETING DATES/TIMES FOR JUNE/JULY 2023**

Director Maybee suggested that all Committee meetings for June would be canceled. He announced that Cal-Waste would be having a meeting May 31, 2023 to discuss the Organics Waste program, and there will be an Open House for Mimi Morris June 7, 2023.

8.

**CORRESPONDENCE**

None.

**9. COMMENTS FROM THE PUBLIC**

None.

**10. RECEIVE UPDATE FROM MARTIN POHLL ON THE GENERAL MANAGER TRANSITION AD HOC COMMITTEE**

Director Pohll updated the Board on the progress of the Ad Hoc Committee.

**11. CONSIDER FORMALIZED PROCESS FOR SECURITY SERVICES WITH RMA**

Director Maybee announced that he has started the process with RMA to formalize the process for Security Services with RMA. An Ad Hoc Committee will be formed.

**12. DIRECTOR COMMENTS/SUGGESTIONS**

Director Butler commented on the March 18, 2023 IWMP town hall meeting.

**13. BOARD ADJOURNED TO CLOSED SESSION TO DISCUSS THE FOLLOWING ITEMS:**

- A. *Closed session regarding General Manager goal setting and performance evaluation process (Gov. Code, § 54957.)*

**14. OPEN SESSION/REPORT ACTION FROM CLOSED SESSION**

Director Maybee reported that no was taken.

**15. ADJOURNMENT**

Director Maybee recognized John Sullivan, former Board Member. **Motion/Maybee to adjourn at 7:05 p.m. Second/Butler. Roll Call Vote: Ayes: Pohll, Jenco, Butler. Noes: None. Absent: Booth. Abstain: None.**

Respectfully submitted,

Amelia Wilder  
District Secretary



## RANCHO MURIETA COMMUNITY SERVICES DISTRICT REGULAR BOARD MEETING MINUTES

June 7, 2023

Open Session 5:00 p.m.

### 1. CALL TO ORDER/ROLL CALL

President Maybee called the Regular Board Meeting of the Board of Directors of Rancho Murieta Community Services District to order at 5:00 p.m. in the District meeting room, 15160 Jackson Road, Rancho Murieta. Director's present at the District office were Tim Maybee, Martin Pohll, Linda Butler, and Stephen Booth. Director Jenco was absent. Also present were Mimi Morris, General Manager; Michael Fritschi, Director of Operations; Susan Wren, Interim Director of Administration; Kelly Benitez, Security Supervisor; Travis Bohannon, Chief Plant Operator; Andrew Ramos, District General Counsel; and Amelia Wilder, District Secretary.

### 2. CONSIDER ADOPTION OF AGENDA

**Motion/Maybee to adopt the Agenda. Second/Booth. Roll Call Vote: Ayes: Maybee, Pohll, Butler, Booth. Noes: None. Absent: Jenco. Abstain: None.**

### 3. CONSENT CALENDAR

**Motion/Maybee to approve Consent Calendar. Second/Booth. Roll Call Vote: Ayes: Maybee, Butler, Pohll, Booth. Noes: None. Absent: Jenco. Abstain: None.**

### 4. REVIEW DISTRICT MEETING DATES/TIMES FOR JUNE/JULY 2023

No changes.

### 5. CORRESPONDENCE

Director Maybee acknowledged the correspondence in the Board Packet.

### 6. PUBLIC HEARING TO INTRODUCE ORDINANCE O2023-03 INCREASING WATER, SEWER AND SOLID WASTE SERVICE CHARGES AND STORM DRAINAGE AND SECURITY SPECIAL TAXES

- A. Director Maybee opened the Public Hearing at 5:02. Mimi Morris, General Manager, introduced the Ordinance, and waived the first reading.
- B. Director Maybee opened the Public Hearing for public comment. There was no comment.
- C. Director Maybee closed the Public Hearing at 5:06. Amelia Wilder, District Secretary, reported that the District had received three (3) protest letters, and there are 2,862 rate payers.
- D. **Motion/Booth to introduce Ordinance O2023-03 and waive the first reading. Second/Maybee.** The Board discussed the rate increases. **Roll Call Vote: Ayes: Maybee, Butler, Pohll, Booth. Noes: None. Absent: Jenco. Abstain: None.**

### 7. INTRODUCE RESOLUTION R2023-08 APPROVING THE PROPOSED BUDGET FOR FISCAL YEAR 2023-24, INCLUDING CAPITAL PROJECTS

Ms. Morris read Resolution R2023-08. She continued with a detailed presentation of the FY23-24 Budget. Susan Wren, Interim Director of Administration, answered questions from the Board and residents John Merchant, Betty Ferraro, and Ted Hart.

Michael Fritschi, Director of Operations, gave a detailed explanation of the proposed Capital Projects.

## **8. CONSIDER APPROVAL OF DISTRICT RESPONSE TO 2022-2023 SACRAMENTO COUNTY GRAND JURY REPORT**

Andrew Ramos, District Legal Counsel, gave a presentation about Grand Jury Reports, and the one prepared about the District. Two responses were prepared, one by Legal Counsel, to be sent to the Grand Jury, and one for the Community prepared by the Board. The response to the Grand Jury is due June 13, 2023. **Motion/Booth** to approve the response prepared for the Grand Jury by Mr. Ramos, with any non-substantive edits from the Board and return it to the Grand Jury. **Second/Pohll. Roll Call Vote: Ayes: Maybee, Butler, Pohll, Booth. Noes: None. Absent: Jenco. Abstain: None.** There was continued discussion about the postings of the Reports on the website. ***The Community response from the Board will be an item at the June 21, 2023 Board Meeting.***

## **9. COMMENTS FROM THE PUBLIC**

Bob Kiel commented on the 670 FSA, the process of permitting of his pending development, and the water infrastructure of the Country Club.

## **10. DIRECTOR COMMENTS/SUGGESTIONS**

The Directors thanked Ms. Morris for joining the District and thanked her and Ms. Wren for their efforts on the Budget.

Director Maybee appointed Directors Booth and Butler to the RMA Security Ad Hoc Committee.

## **11. ADJOURNMENT**

**Motion/Butler** to adjourn at 7:17 p.m. **Second/Booth. Roll Call Vote: Ayes: Maybee, Pohll, Butler, Booth. Noes: None. Absent: Jenco. Abstain: None.**

Respectfully submitted,

Amelia Wilder  
District Secretary

DATE: June 13, 2023  
TO: Board of Directors  
FROM: Susan Wren, Interim Director of  
SUBJECT: Administration Receive and File Check Journal

Attached is a list of checks numbered 11004 through 11083 issued between April 1, 2023 and April 30, 2023. Invoices were presented by departments, reviewed by administration staff and subsequent checks were issued. All checks were in conformity with the District's policies and procedures. Monies were available to pay the amounts listed.

The Board is asked to receive and file this information.

#### FISCAL ANALYSIS

Seventy-two (72) checks totaling \$371,973.93 were issued and eight checks were voided between April 1, 2023 and April 30, 2023.

#### ATTACHMENT

Accounts Payable Vendor Check Register Report from April 1, 2023 through April 30, 2023.

Ranges: From: To: From: To:  
 Check Number First Last Check Date 4/1/2023 4/30/2023  
 Vendor ID First Last Checkbook ID First Last  
 Vendor Name First Last

Sorted By: Check Date

\* Voided Checks

Check Number	Check Date	Vendor	Checkbook ID	Amount
0011004	4/4/2023	ABA Protection Inc.	CSD CHECKING	\$3,203.18
0011005	4/4/2023	ABS Direct	CSD CHECKING	\$2,949.75
0011006	4/4/2023	A Leap Ahead IT	CSD CHECKING	\$8,922.83
0011007	4/4/2023	Apple One Employment Services	CSD CHECKING	\$4,027.15
0011008	4/4/2023	Aramark Uniform & Career Apparel, LLC	CSD CHECKING	\$189.85
0011009	4/4/2023	Caltronics	CSD CHECKING	\$132.63
0011010	4/4/2023	Camberos Landscaping	CSD CHECKING	\$385.00
0011011	4/4/2023	Clark Pest Control	CSD CHECKING	\$739.00
0011012	4/4/2023	Corelogic Solutions, LLC	CSD CHECKING	\$225.10
0011013	4/4/2023	Daily Journal Corporation	CSD CHECKING	\$535.50
0011014	4/4/2023	Domenichelli and Associates, Inc	CSD CHECKING	\$1,330.00
0011015	4/4/2023	Ferrellgas	CSD CHECKING	\$238.73
0011016	4/4/2023	HDR Engineering, Inc	CSD CHECKING	\$7,040.60
0011017	4/4/2023	LUXURY CLEANING SERVICE	CSD CHECKING	\$2,000.00
0011018	4/4/2023	Metal Samples Company	CSD CHECKING	\$219.62
0011019	4/4/2023	Mobile Mini Solutions	CSD CHECKING	\$242.44
0011020	4/4/2023	Operating Engineers Local Union No. 3	CSD CHECKING	\$731.04
0011021	4/4/2023	Ron Greenfield	CSD CHECKING	\$110.60
0011022	4/4/2023	Stephanie Bianchi	CSD CHECKING	\$297.26
0011023	4/4/2023	Tree Tech Services	CSD CHECKING	\$2,130.00
0011024	4/4/2023	Ueware, Inc.	CSD CHECKING	\$2,280.00
0011025	4/4/2023	Vitaliy Perepelka	CSD CHECKING	\$93.38
0011026	4/4/2023	Wagner & Bonsignore Consulting Civil Engine	CSD CHECKING	\$195.00
0011027	4/4/2023	Walker's Office Supplies, Inc	CSD CHECKING	\$517.20
0011028	4/4/2023	Wenker, Ryan	CSD CHECKING	\$76.36
0011029	4/4/2023	Amelia Wilder	CSD CHECKING	\$64.98
0011030	4/4/2023	Zep Sales & Service	CSD CHECKING	\$4,474.99
0011031	4/11/2023	A&D Automatic Gate and Access	CSD CHECKING	\$224.36
0011032	4/11/2023	ABA Protection Inc.	CSD CHECKING	\$1,230.13
0011033	4/11/2023	Adkins Consulting Engineering, LLP	CSD CHECKING	\$20,043.75
0011034	4/11/2023	A Leap Ahead IT	CSD CHECKING	\$95.33
0011035	4/11/2023	Applications By Design, Inc.	CSD CHECKING	\$35.00
0011036	4/11/2023	Aqua-Metric Sales Company	CSD CHECKING	\$7,181.54
0011037	4/11/2023	Aramark Uniform & Career Apparel, LLC	CSD CHECKING	\$185.14
0011038	4/11/2023	California Laboratory Services	CSD CHECKING	\$1,579.00
0011039	4/11/2023	ECS House Industries, Inc.	CSD CHECKING	\$2,569.84
0011040	4/11/2023	GM Crane Services, Inc	CSD CHECKING	\$475.00
0011041	4/11/2023	James Colas	CSD CHECKING	\$128.26
0011042	4/11/2023	Mel Outram	CSD CHECKING	\$120.10
0011043	4/11/2023	Ojo Technology	CSD CHECKING	\$2,402.91
0011044	4/11/2023	Pace Supply Corp	CSD CHECKING	\$3,642.90
0011045	4/11/2023	Rancho Murieta Country Club	CSD CHECKING	\$795.36
0011046	4/11/2023	RingCentral Inc	CSD CHECKING	\$10,077.90
0011047	4/11/2023	Rogers Machinery Company, Inc	CSD CHECKING	\$2,750.00
0011048	4/11/2023	Solitude Lake Management LLC	CSD CHECKING	\$2,275.00
0011050	4/11/2023	United Rentals Northwest, Inc.	CSD CHECKING	\$3,549.47
0011051	4/11/2023	waterTALENT LLC	CSD CHECKING	\$5,694.00
0011052	4/11/2023	Wenker, Ryan	CSD CHECKING	\$110.00
0011053	4/11/2023	W.W. Grainger Inc.	CSD CHECKING	\$2,440.54
0011054	4/11/2023	Zenon Environmental Corporation	CSD CHECKING	\$13,058.76
0011055	4/13/2023	Beau Kirby	CSD CHECKING	\$72.00
0011056	4/13/2023	County of Sacramento	CSD CHECKING	\$664.00
0011057	4/13/2023	FIDELITY NATIONAL TITLE	CSD CHECKING	\$150.00
0011058	4/13/2023	Tawanda Mitchell	CSD CHECKING	\$1,500.00
0011059	4/20/2023	Apple One Employment Services	CSD CHECKING	\$1,273.44
0011060	4/20/2023	California Waste Recovery Systems	CSD CHECKING	\$87,277.34
0011061	4/20/2023	Corelogic Solutions, LLC	CSD CHECKING	\$225.10
0011062	4/20/2023	CUES, Inc.	CSD CHECKING	\$5,149.54

\* Voided Checks

Check Number	Check Date	Vendor	Checkbook ID	Amount
0011063	4/20/2023	FIDELITY NATIONAL TITLE	CSD CHECKING	\$234.32
0011064	4/20/2023	FIRST AMERICAN TITLE CO	CSD CHECKING	\$147.12
0011065	4/20/2023	Greenfield Communications	CSD CHECKING	\$448.99
0011066	4/20/2023	K.Hovnanian Homes Northern California INC	CSD CHECKING	\$42,748.37
0011067	4/20/2023	Kirby's Pump & Mechanical Inc.	CSD CHECKING	\$5,000.00
0011068	4/20/2023	Lucy & Company	CSD CHECKING	\$16,174.73
0011069	4/20/2023	Operating Engineers Local Union No. 3	CSD CHECKING	\$731.04
0011077	4/20/2023	State of California	CSD CHECKING	\$175.00
0011078	4/20/2023	Watchdogs Surveillance	CSD CHECKING	\$888.75
0011079	4/20/2023	Useware, Inc.	CSD CHECKING	\$380.00
0011080	4/20/2023	Tyler Technologies, INC	CSD CHECKING	\$1,820.00
0011081	4/20/2023	Stratus Engineering Associates LLC	CSD CHECKING	\$8,147.71
0011082	4/20/2023	Streamline	CSD CHECKING	\$300.00
0011083	4/20/2023	State of California	CSD CHECKING	\$74,450.00
				-----
Total Checks:	72		Total Amount of Checks:	\$371,973.93



DATE: June 13, 2023  
TO: Board of Directors  
FROM: Susan Wren, Interim Director of Administration  
SUBJECT: Receive and File May 2023 Check Journal

Attached is a list of checks numbered 11084 through 11190 issued between May 1, 2023 and May 31, 2023. Invoices were presented by departments, reviewed by administration staff and subsequent checks were issued. All checks were in conformity with the District's policies and procedures. Monies were available to pay the amounts listed.

The Board is asked to receive and file this information.

#### FISCAL ANALYSIS

One hundred and seven (107) checks totaling \$983,590.25 were issued between May 1, 2023 and May 31, 2023.

#### ATTACHMENT

Accounts Payable Vendor Check Register Report from May 1, 2023 through May 31, 2023.

Ranges: From: To: From: To:  
 Check Number First Last Check Date 5/1/2023 5/31/2023  
 Vendor ID First Last Checkbook ID First Last  
 Vendor Name First Last

Sorted By: Check Date

\* Voided Checks

Check Number	Check Date	Vendor	Checkbook ID	Amount
0011084	5/5/2023	A Leap Ahead IT	CSD CHECKING	\$181.02
0011085	5/5/2023	ABS Direct	CSD CHECKING	\$1,300.00
0011086	5/5/2023	Accounting & Association Software Group	CSD CHECKING	\$4,186.25
0011087	5/5/2023	Adkins Engineering and Surveying, Inc.	CSD CHECKING	\$51,667.88
0011088	5/5/2023	Bartkiewicz, Kronick & Shanahan	CSD CHECKING	\$12,626.48
0011089	5/5/2023	Best Best & Krieger	CSD CHECKING	\$7,216.00
0011090	5/5/2023	Caltronics	CSD CHECKING	\$125.99
0011091	5/5/2023	Clark Pest Control	CSD CHECKING	\$739.00
0011092	5/5/2023	Concentra DBA Occupational Health Centers	oCSD CHECKING	\$706.00
0011093	5/5/2023	Domenichelli and Associates, Inc	CSD CHECKING	\$4,290.00
0011094	5/5/2023	FIRST AMERICAN TITLE CO	CSD CHECKING	\$169.02
0011095	5/5/2023	GSRMA	CSD CHECKING	\$259,929.72
0011096	5/5/2023	HDR Engineering, Inc	CSD CHECKING	\$1,512.53
0011097	5/5/2023	Heather Pedro	CSD CHECKING	\$188.50
0011098	5/5/2023	Municipal Resource Group, LLC	CSD CHECKING	\$4,003.64
0011099	5/5/2023	Pitney Bowes	CSD CHECKING	\$506.70
0011100	5/5/2023	Public Agency Retirement Services	CSD CHECKING	\$2,035.57
0011101	5/5/2023	Rancho Murieta Association	CSD CHECKING	\$1,007.04
0011102	5/5/2023	Robert Half	CSD CHECKING	\$1,757.88
0011103	5/5/2023	Sierra Foothill Fire Extinguisher Service	CSD CHECKING	\$771.24
0011104	5/5/2023	Tyler Technologies, INC	CSD CHECKING	\$9,955.00
0011105	5/5/2023	Walker's Office Supplies, Inc	CSD CHECKING	\$585.26
0011106	5/15/2023	ELK GROVE TOYOTA	CSD CHECKING	\$32,892.57
0011107	5/15/2023	A&D Automatic Gate and Access	CSD CHECKING	\$448.73
0011108	5/15/2023	ABA Protection Inc.	CSD CHECKING	\$796.25
0011109	5/15/2023	Accounting & Association Software Group	CSD CHECKING	\$1,128.75
0011110	5/15/2023	Adkins Consulting Engineering, LLP	CSD CHECKING	\$690.00
0011111	5/15/2023	Aramark Uniform & Career Apparel, LLC	CSD CHECKING	\$410.17
0011112	5/15/2023	Arnolds For Awards	CSD CHECKING	\$55.68
0011113	5/15/2023	Charlene Bastian	CSD CHECKING	\$123.01
0011114	5/15/2023	Best Best & Krieger	CSD CHECKING	\$1,276.00
0011115	5/15/2023	Borges & Mahoney	CSD CHECKING	\$928.50
0011116	5/15/2023	Camberos Landscaping	CSD CHECKING	\$385.00
0011117	5/15/2023	Corrpro Companies, Inc.	CSD CHECKING	\$820.00
0011118	5/15/2023	County of Sacramento	CSD CHECKING	\$664.00
0011119	5/15/2023	Dewberry Engineers Inc.	CSD CHECKING	\$1,062.00
0011120	5/15/2023	East Bay Municipal Utility District	CSD CHECKING	\$859.00
0011121	5/15/2023	Folsom Lake Ford, Inc.	CSD CHECKING	\$697.11
0011122	5/15/2023	Holt of California	CSD CHECKING	\$2,871.42
0011123	5/15/2023	JWC Environmental	CSD CHECKING	\$4,682.45
0011124	5/15/2023	Pace Supply Corp	CSD CHECKING	\$490.31
0011125	5/15/2023	Prodigy Electric & Controls Inc.	CSD CHECKING	\$20,412.00
0011126	5/15/2023	Russ Branson Consulting	CSD CHECKING	\$8,810.41
0011127	5/15/2023	S. M. U. D.	CSD CHECKING	\$18,018.47
0011128	5/15/2023	State of California	CSD CHECKING	\$636.23
0011129	5/15/2023	USA Blue Book	CSD CHECKING	\$5,236.47
0011130	5/15/2023	waterTALENT LLC	CSD CHECKING	\$12,967.50
0011131	5/15/2023	WECO Industries	CSD CHECKING	\$956.60
0011132	5/17/2023	49ER WATER	CSD CHECKING	\$950.00
0011133	5/17/2023	ABS Direct	CSD CHECKING	\$7,550.30
0011134	5/17/2023	Applications By Design, Inc.	CSD CHECKING	\$1,260.00
0011135	5/17/2023	Aramark Uniform & Career Apparel, LLC	CSD CHECKING	\$369.93
0011136	5/17/2023	B & M BUILDERS	CSD CHECKING	\$20,017.00
0011137	5/17/2023	California Waste Recovery Systems	CSD CHECKING	\$87,948.50
0011138	5/17/2023	Caltronics Business Systems	CSD CHECKING	\$582.74
0011139	5/17/2023	Chemtrade Chemicals US LLC	CSD CHECKING	\$7,417.91
0011140	5/17/2023	CIT	CSD CHECKING	\$475.22
0011141	5/17/2023	Concentra DBA Occupational Health Centers	oCSD CHECKING	\$547.00

\* Voided Checks

Check Number	Check Date	Vendor	Checkbook ID	Amount
0011142	5/17/2023	Connexus Industries	CSD CHECKING	\$1,087.82
0011143	5/17/2023	County of Sacramento	CSD CHECKING	\$84.00
0011144	5/17/2023	Greenfield Communications	CSD CHECKING	\$448.99
0011145	5/17/2023	Intelligent Technical Solutions, LLC	CSD CHECKING	\$7,350.08
0011146	5/17/2023	LUXURY CLEANING SERVICE	CSD CHECKING	\$2,000.00
0011147	5/17/2023	Municipal Resource Group, LLC	CSD CHECKING	\$9,281.25
0011148	5/17/2023	Operating Engineers Local Union No. 3	CSD CHECKING	\$731.04
0011149	5/17/2023	Robert Half	CSD CHECKING	\$16,043.72
0011150	5/17/2023	SIERRA VALLEY CONTRACTORS	CSD CHECKING	\$7,855.00
0011151	5/17/2023	Solitude Lake Management LLC	CSD CHECKING	\$8,125.00
0011152	5/17/2023	State of California	CSD CHECKING	\$64.00
0011153	5/17/2023	Streamline	CSD CHECKING	\$300.00
0011154	5/17/2023	The Pun Group, LLC	CSD CHECKING	\$98,019.31
0011155	5/17/2023	TNT Industrial Contractors Inc.	CSD CHECKING	\$39,874.00
0011156	5/17/2023	Tyler Technologies, INC	CSD CHECKING	\$2,795.00
0011157	5/17/2023	Univar Solutions USA Inc	CSD CHECKING	\$4,961.16
0011158	5/17/2023	Univar USA Inc.	CSD CHECKING	\$4,238.95
0011159	5/17/2023	USA Blue Book	CSD CHECKING	\$535.80
0011160	5/17/2023	waterTALENT LLC	CSD CHECKING	\$3,510.00
0011161	5/30/2023	Big Valley Tractor LLC	CSD CHECKING	\$7,610.38
0011162	5/31/2023	ABA Protection Inc.	CSD CHECKING	\$2,466.77
0011163	5/31/2023	ABS Direct	CSD CHECKING	\$5,955.83
0011164	5/31/2023	Accounting & Association Software Group	CSD CHECKING	\$371.25
0011165	5/31/2023	Aadkins Consulting Engineering, LLP	CSD CHECKING	\$7,390.00
0011166	5/31/2023	Aestiva Software, Inc.	CSD CHECKING	\$5,167.29
0011167	5/31/2023	Aramark Uniform & Career Apparel, LLC	CSD CHECKING	\$181.65
0011168	5/31/2023	Best Best & Krieger	CSD CHECKING	\$3,322.00
0011169	5/31/2023	Borges & Mahoney	CSD CHECKING	\$591.13
0011170	5/31/2023	Caltronics	CSD CHECKING	\$11,360.00
0011171	5/31/2023	Compressed Air Services	CSD CHECKING	\$1,077.91
0011172	5/31/2023	Concentra DBA Occupational Health Centers	CSD CHECKING	\$979.00
0011173	5/31/2023	Corelogic Solutions, LLC	CSD CHECKING	\$225.10
0011174	5/31/2023	Domenichelli and Associates, Inc	CSD CHECKING	\$34,252.50
0011175	5/31/2023	Domino Solar LTD	CSD CHECKING	\$8,063.04
0011176	5/31/2023	EataFig Productions	CSD CHECKING	\$200.00
0011177	5/31/2023	Lucy & Company	CSD CHECKING	\$9,198.75
0011178	5/31/2023	Mel Outram	CSD CHECKING	\$44.61
0011179	5/31/2023	Michael Fritschi	CSD CHECKING	\$180.00
0011180	5/31/2023	Robert Half	CSD CHECKING	\$2,127.96
0011181	5/31/2023	Roger Formanek	CSD CHECKING	\$100.00
0011182	5/31/2023	S. M. U. D.	CSD CHECKING	\$19,481.63
0011183	5/31/2023	SIERRA VALLEY CONTRACTORS	CSD CHECKING	\$2,100.00
0011184	5/31/2023	Staples Construction Co., Inc	CSD CHECKING	\$22,495.92
0011185	5/31/2023	Tree Tech Services	CSD CHECKING	\$4,200.00
0011186	5/31/2023	USA Blue Book	CSD CHECKING	\$39.46
0011187	5/31/2023	Useware, Inc.	CSD CHECKING	\$4,750.00
0011188	5/31/2023	Valley Oak Press, Inc.	CSD CHECKING	\$275.00
0011189	5/31/2023	Wagner & Bonsignore Consulting Civil Engine	CSD CHECKING	\$585.00
0011190	5/31/2023	waterTALENT LLC	CSD CHECKING	\$10,595.00

Total Checks: 107

Total Amount of Checks: \$983,590.25

## Memorandum

Date: June 21, 2023  
To: Board of Directors  
From: Mimi Morris, General Manager  
Subject: General Manager's Report

---

### **ADMINISTRATION**

#### **GENERAL STAFFING UPDATE**

Mimi Morris began as the new General Manager for the District on the 17<sup>th</sup> of May.

Michael Fritschi will be resuming his duties as the Operations Director and aiding Ms. Morris as she becomes situated in her new position. Travis Bohannon will be resuming his duties as Chief Plant Operator.

In late April, Director of Administration Paula O'Keefe left the District to accept another job. Susan Wren, a Retired Annuitant, is currently filling the role as the Interim Director of Administration. The District expects to initiate a formal recruitment for the Director of Administration within the next few weeks. The position is being restructured to encompass both administration and financial management. The Accounting Manager position will be eliminated. This is a return to a staffing model that existed over ten years ago.

#### **FEMA DISASTER RELIEF**

The 2022 New Year's Eve storm resulted in extensive damage to District infrastructure. The District was eligible for federal assistance for these costs and has worked with FEMA to request reimbursements. The District is nearing completion of the reporting effort and will likely receive a reimbursement of 75% of funds expended attending to and repairing issues caused by the New Year's Eve flood.

#### **DROUGHT RELIEF WATER RECLAMATION GRANTS**

The District is working with a consultant to establish potential project funding through a drought relief grant funding opportunity from the State Water Resources Control Board. The Integrated Water Master Plan will include drought relief and source development alternatives. One of the potentially funded projects is expected to include the use of automatic meter reading technology at every connection that does not currently have the capability to provide real time use and leak detection.

### **CONFERENCE/EDUCATIONAL OPPORTUNITIES**

#### **SACRAMENTO REGIONAL WASTEWATER TOUR**

On June 15<sup>th</sup>, The General Manager, Operations Director, and the Chief Plant Operator attended a tour of the Sacramento Regional Treatment Facility organized by the California Water Environment Association to introduce various wastewater treatment practices.

## UPCOMING CONFERENCES & TRAININGS

California Special Districts Association (CSDA) is offering Leadership Academy Conference on October 22-25 (Santa Rosa) and the Annual Conference on August 28-31 (Monterey). American Water Works Association (AWWA) is offering a rate setting Essentials Seminar on November 15-17 (San Diego). Ms. Morris will be attending the General Manager Leadership Summit in Lake Tahoe on June 25 – 27th.

## EMPLOYEE TRAINING

Amelia Wilder attended the City Clerks Training put on by the City Clerks Association of California. Travis Bohannon completed a 2023 CWEA Leadership Training Program.

## EXAMS PASSED

Heather Pedro passed her Water Treatment II Exam, Ed McMurray passed his Water Treatment III Exam, and Travis Bohannon passed his Water Treatment IV Exam. Congratulations Ms. Pedro, Mr. McMurray, and Mr. Bohannon!

## **DEVELOPMENT**

### RESIDENCES EAST

The Residences East and Residences West Developer (River Canyon Properties, LLC) has submitted the initial development deposits to provide review of the grading and drainage studies for the Residence East and West. The District met with the representatives of River Canyon and discussed the development process.

### RETREATS NORTH

With the exception of work on Retreats North infrastructure that cannot be accessed due to soil saturation, and lead times for Lift station 6B equipment, K Hovnanian Homes has completed the utility items on the punch list for the North phases of the Retreats development. K Hovnanian has submitted the required items needed for the District Board to formally accept the infrastructure and start the warranty period for the donated infrastructure. The Resolution approving the acceptance of the utility infrastructure will be presented to the Board at the July Board meeting. Once accepted, the infrastructure will be booked into a District depreciation schedule.

### PET HOSPITAL

Water line re-alignment has successfully occurred for the Pet Hospital and the building progress has continued.

### RIVERVIEW

The District is in the process of reviewing the record drawings for the completed Riverview phase 1A & 1B improvements and has provided comments regarding the Phase 2 design of utilities improvements.

## **OUTREACH & REGIONAL COMMUNICATION**

### GRAND JURY REPORT RESPONSES

On June 12<sup>th</sup> the District submitted the formal response to the 2023 Grand Jury Report to the Presiding Judge of the Grand Jury.

The District will also be finalizing a Community response to the Grand Jury report which will contain a more substantial response to the findings and recommendations and will also provide links to the supporting documents.

**6B Administration/Finance Report - Pending**

## MEMORANDUM

Date: June 21, 2023  
To: Board of Directors  
From: Kelly Benitez, Security Supervisor  
Subject: Security Update Report for the Month of April-May

---

### **OPERATIONS UPDATES**

The Department:

1. Currently has eight full-time and two part-time gate officers and three patrol officers.
2. Is holding vacant three patrol officer positions due to the budget reductions;
3. We had 90 patrol shifts in April and 34 were not covered. We had 93 patrol shifts in May and 35 of them were not covered.
4. Responded to a total of 553 calls between January 1<sup>st</sup> and June 1<sup>st</sup>, 2023. Of these:
  - a. 483 (87.4%) calls originated inside the RMA gates and
  - b. 70 (12.6%) calls originated outside the RMA gates
5. Upgraded security vehicles with the purchase of a new Toyota truck, with RMCS Security signage and radios.
6. Received Ballistic Vests for the patrol officers.
7. Purchased uniforms for part-time employees at the 6-month mark, this was a cost-saving measure.

### **Rancho Murieta Association activity:**

Security staff continue to work with the RMA Leadership on a regular basis to improve our level of service and have positive contact with residents. Current topics include:

- General non-architectural rules enforcement (see Violation Summary Report); continued to attend RMA Compliance meetings.
- Spoke with the Director of Compliance (Chris Smith)
- South Beach incident (RMA rule)
- New General Manager (July 4<sup>th</sup> Coverage)
- Vandalism Wash
- Garage Door Open issue
- Boat citation increase due to increased monitoring and enforcement. This RMA rule has seen an increase in CSD citations.

### **Community Meetings**

- Met with Lt. Greg Coauette SSD.
- Met with President Garden HOA.
- Sgt Outram E-Center.

**Rancho Murieta Association**  
**Violation Item Summary Report -- 2023**  
(This report includes RMA & CSD issued violations)

Violation Item Summary Report	Jan		Feb		March		April		May		June		July	
	CSD	RMA	CSD	RMA	CSD	RMA	CSD	RMA	CSD	RMA	CSD	RMA	CSD	RMA
<b>Motor vehicle violations:</b>														
Motorcycle														
No drivers license			0	1					1	0				
Speeding	0	37	16	70	19	47	29	48	25	27				
Speeding - twice speed limit														
Stop signs	17	7	35	18	11	9	29	1	18	9				
Bus stop signs														
Use of streets							0	1	1	0				
<b>Parking:</b>														
Driveway parking	0	3			10	16	4	7	0	13				
Guest parking					3	0	2	4	1	4				
Overnight street parking	0	1			2	13	12	4	27	7				
Unauthorized Vehicle (24 hr pass)			1	0	1	6	0	3	0	1				
Accumulation/dumping of debris			0	2			0	1	0	1				
Boat Usage					1	0	2	0	3	0				
Barbeques, open fires, bonfires														
Carrying passengers/overloaded cart									0	1				
Clothes lines														
Commercial vehicle lettering	0	1							0	1				
Construction overnight parking														
Park hours / curfew			2	0			1	0						
Decorative lights														
Discharge of firearm														
Chickens					0	1	0	1	0	3				
Dwelling exterior alterations														
Failure to identify														
Fences, screens & enclosures														
Guest w/o resident in comm areas			1	0					0	1				
Home business activities														
Noxious activities									1	0				
Open garage doors									9	0				
Pets - off leash / teathered / noise	0	1	1	0	0	1	1	0						
Property maintenance			0	4	0	3	0	28	0	22				
Sign rules					0	1								
Skating in common area														
Sports equip/trampoline/basketball	0	2	0	2	0	6	0	5	0	8				
Storage of building materials														
Stored vehicles							0	1	0	5				
Trash containers			0	2	0	3	0	1	0	4				
Use of common areas & facilities	0	2	0	2										
Vandalism														
Vehicle repair or maintenance														
Interference RMA/RMCS														
Working days & hours														
<b>Total Violations</b>	<b>17</b>	<b>54</b>	<b>56</b>	<b>101</b>	<b>47</b>	<b>106</b>	<b>80</b>	<b>105</b>	<b>86</b>	<b>107</b>	<b>0</b>	<b>0</b>	<b>0</b>	<b>0</b>
Citations written by RMCS		17		56		47		80		86		0		0
Citations written by RMA		54		101		106		105		107		0		0
<b>Total Violations</b>		<b>71</b>		<b>157</b>		<b>153</b>		<b>185</b>		<b>193</b>		<b>0</b>		<b>0</b>





# Gate Entries by Type

## April 2023

Pass Type	Guest Count North Gate	Guest Count South Gate	Count by Pass Type
Construction	298	388	686
Guest	4811	2572	7383
Real Estate	85	25	110
Vendor	2805	1357	4162
Country Club (x)	982	4	986
Special Event	767	35	802
<b>TOTALS</b>	<b>9748</b>	<b>4381</b>	<b>14129</b>

Prior Month Totals: 9712 4225 14118

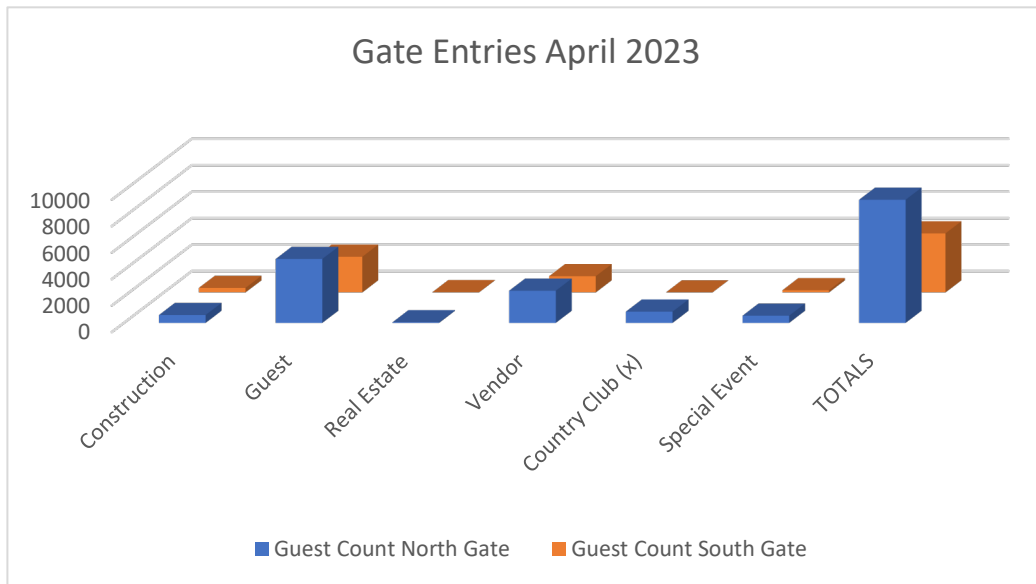

# Gate Entries by Type

May 2023

Pass Type	Guest Count North Gate	Guest Count South Gate	Count by Pass Type
Construction	72	265	337
Guest	5,684	2,748	8,432
Real Estate	95	22	117
Vendor	3,336	1,235	4,571
Country Club (x)	1,345	4	1,349
Special Event	897	32	929
<b>TOTALS</b>	<b>11,429</b>	<b>4,306</b>	<b>15,735</b>

Prior Month Totals: 9,748 4,381 14,129

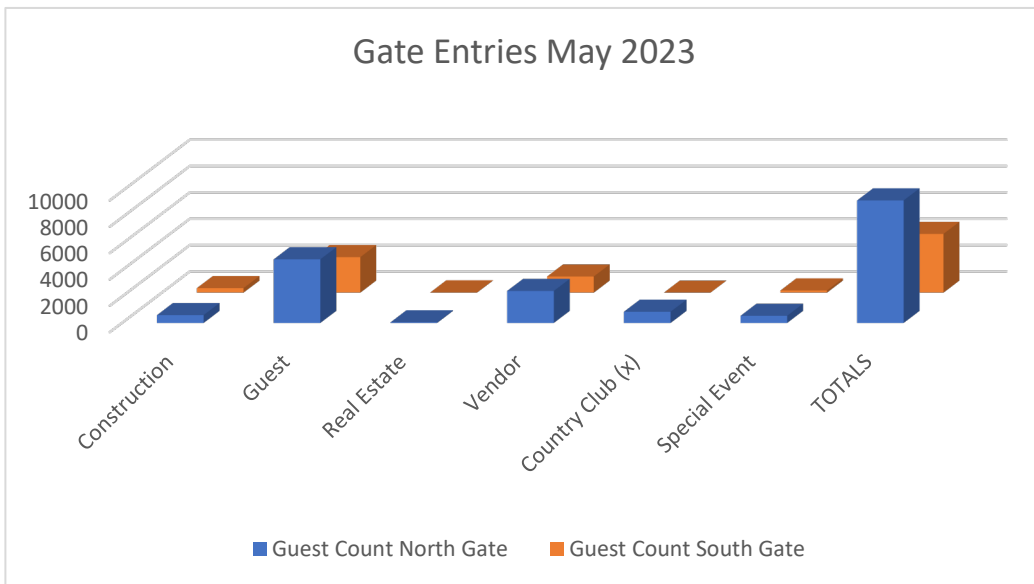

## Gate Entries Denied

**April 1-30, 2023**

	Lookers	Resident Refused	Vendor After Hours	No Answer at Resident	Other	Lake/ Park Access	TOTAL
<b>All Gates</b>	15	10	27	3	4	8	67

**Prior Month Totals:**                      13                      6                      10                      7                      1                      3                      40

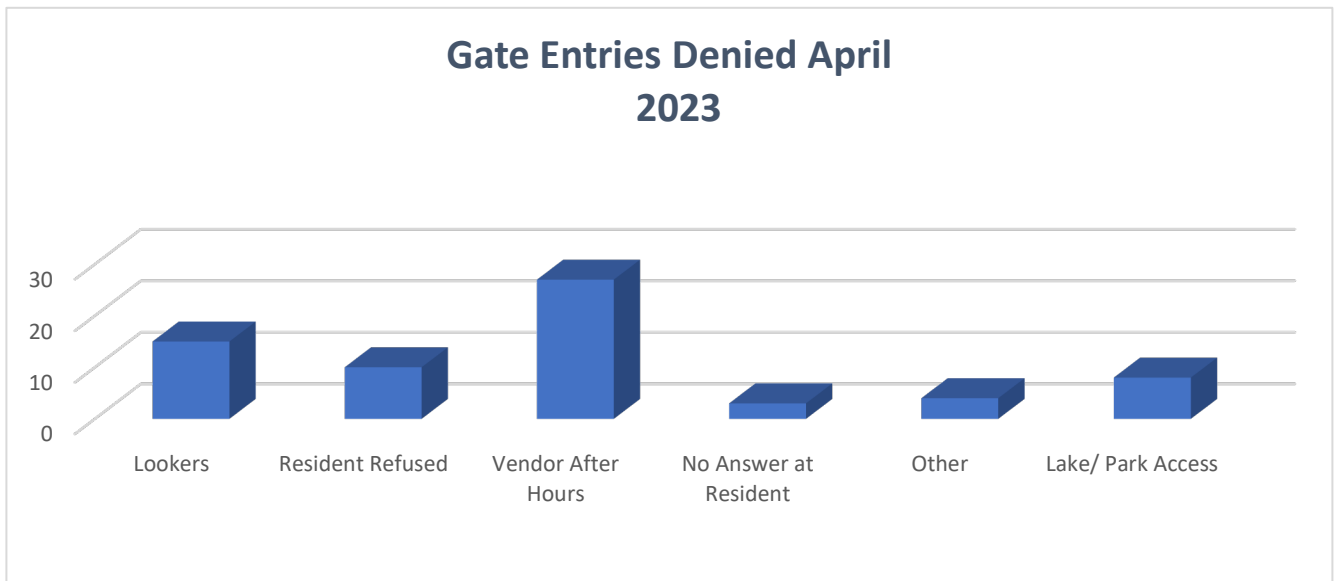

## Gate Entries Denied

**May 1-31, 2023**

	Lookers	Resident Refused	Vendor After Hours	No Answer at Resident	Other	Lake/ Park Access	TOTAL
<b>All Gates</b>	15	9	24	7	8	17	80

**Prior Month Totals:**                      15                      7                      27                      3                      0                      8                      60

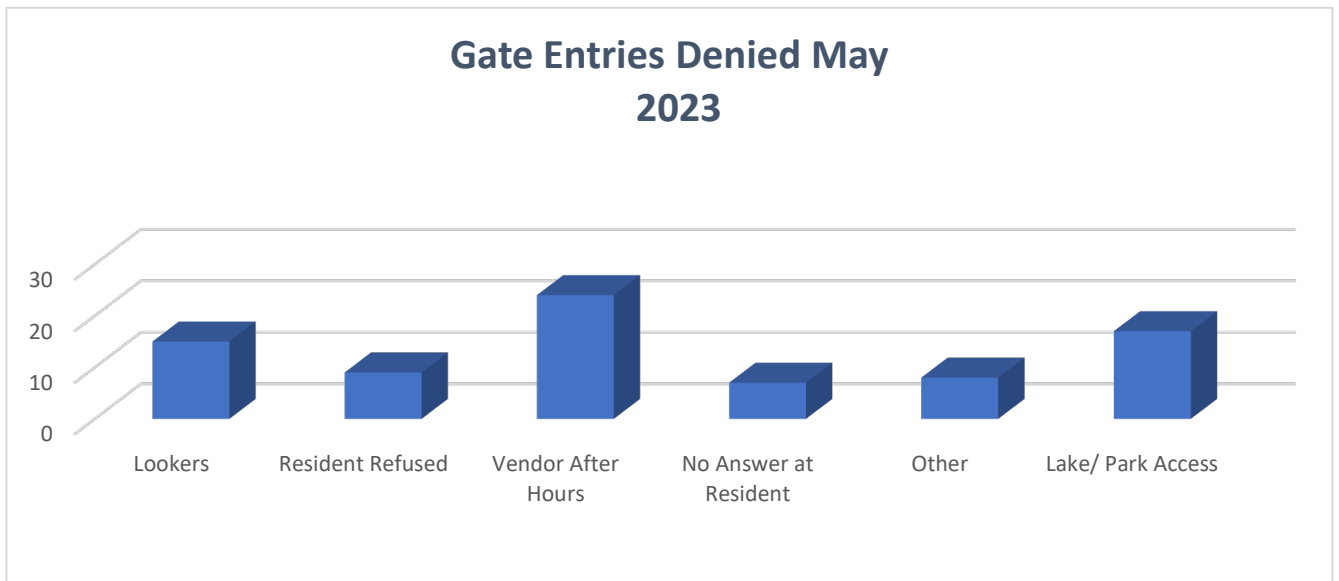



**Rancho Murieta CSD Security**

15160 Jackson Rd  
Rancho Murieta, CA 95662

**Cases - Breakdown by Type**

ABANDONED DISABLED VEH	1
ALARM	2
ANIMAL COMPLAINT	9
CITATION	72
DISTURBANCE	3
ESCORT	1
EXTRA PATROL	10
FOLLOW UP	2
INTOXICATED PERSON	1
IRRIGATION DAMAGE	1
JUVENILE DELIQUENCY	5
LOST/FOUND PROPERTY	4
MISCELLANEOUS	24
OPEN DOOR	6
PETTY THEFT	1
REFUSED ENTRY	66
RESIDENT COMPLAINT	24
RMA RULE VIOLATION	9
SPEEDING COMPLAINT	2
SUSPICIOUS PERSON	2
SUSPICIOUS VEHICLE	1
TRAFFIC ENFORCEMENT	36
TRESPASSING	5
VANDALISM	3
VEHICLE ACCIDENT	8

WATER LEAK	5
WEATHER RELATED	1
WELFARE CHECK	7
Total	311





**Rancho Murieta CSD Security**

15160 Jackson Rd  
Rancho Murieta, CA 95662

**Cases - Breakdown by Type**

ABANDONED DISABLED VEH	4
ALARM	4
ANIMAL COMPLAINT	13
ASSIST OTHER AGENCY	6
CITATION	68
DISTURBANCE	1
ESCORT	4
EXTRA PATROL	46
FOLLOW UP	3
GAS LEAK	1
IRRIGATION DAMAGE	1
JUVENILE DELIQUENCY	11
LOST/FOUND PROPERTY	3
MISCELLANEOUS	11
MISSING PERSON	1
PARKING	1
PETTY THEFT	1
REFUSED ENTRY	81
RESIDENT COMPLAINT	23
RMA RULE VIOLATION	12
SPEEDING COMPLAINT	2
SUSPICIOUS ACTIVITY	1
SUSPICIOUS PERSON	3
SUSPICIOUS VEHICLE	2
TRAFFIC ENFORCEMENT	26





**Rancho Murieta CSD Security**

15160 Jackson Rd  
Rancho Murieta, CA 95662

**Cases - Breakdown by Type**

ABANDONED DISABLED VEH	1
ALARM	2
ANIMAL COMPLAINT	9
CITATION	72
DISTURBANCE	3
ESCORT	1
EXTRA PATROL	10
FOLLOW UP	2
INTOXICATED PERSON	1
IRRIGATION DAMAGE	1
JUVENILE DELIQUENCY	5
LOST/FOUND PROPERTY	4
MISCELLANEOUS	24
OPEN DOOR	6
PETTY THEFT	1
REFUSED ENTRY	66
RESIDENT COMPLAINT	24
RMA RULE VIOLATION	9
SPEEDING COMPLAINT	2
SUSPICIOUS PERSON	2
SUSPICIOUS VEHICLE	1
TRAFFIC ENFORCEMENT	36
TRESPASSING	5
VANDALISM	3
VEHICLE ACCIDENT	8

<b>WATER LEAK</b>	<b>5</b>
<b>WEATHER RELATED</b>	<b>1</b>
<b>WELFARE CHECK</b>	<b>7</b>
<b>Total</b>	<b>311</b>



TRESPASSING	4
VANDALISM	6
VEHICLE ACCIDENT	6
WATER LEAK	15
WEATHER RELATED	1
WELFARE CHECK	8
Total	369



**INCIDENTS OF NOTE**  
**April-May 2023**

On April 14, 2023, at approximately 1813 hours, security personnel responded to a Golf Cart accident on Hole Three South Golf Course. The Golf Cart in question had crashed into the wooded barricade, however, there were no injuries. The minor driving the golf cart (permit-only) with the father's permission stated that another golf cart was driving recklessly. The minor took evasive action to avoid a head-on collision, resulting in a crash into the wooden barricade. The suspect fled without stopping and he has not been identified to this date.

On May 8<sup>th</sup>, 2023, at 1300 hours, FBI Special Agent responded and advised our North Gate officer that he was investigating a possible Uranium Rock located at a residence in the North. The conclusion of the investigation was that the specimen was harmless to the community however, the rock was taken into custody by the FBI.

On May 15, 2023, vandalism occurred at Stonehouse Park. The suspected vandalized the women's bathroom.

On May 25, 2023, at 0920 hours, CSD Security responded to a residence on Reynosa Drive of a burglary. The victim lives at the residence seasonally and upon his return had discovered that an unknown suspect had entered the home and ransacked the residence and removed selected property and fled the location. A report and investigation were conducted by SSD.

## MEMORANDUM

Date: June 21, 2023  
To: Board of Directors  
From: Travis Bohannon, Interim Director of Operations  
Subject: Operations Report

---

### **WATER**

#### **Water Treatment Facility**

Plant 1 and Plant 2 are both in operation and are currently producing potable water at a rate of 2.3 million gallons a day. **NOTE:** On a raw water sample taken for manganese on 6/7/23, the lab reported to the District and to the state of a maximum contaminant level (MCL) exceedance in Influent Manganese. The report states that the raw sample was at 130 ug/l (0.13 mg/L). The MCL for effluent drinking water influent is 0.05 mg/L. This is not an issue, as the plant was able to reduce the manganese effectively prior to use under the MCL.

#### **Water Consumption**

As of June 1, 2023, cumulative potable water production for the current year is 143.9 million gallons. That is currently 30.3 million gallons (17%) **less** than the same use period in 2022 and 22.4 million gallons (13%) **less** than 2020.

#### **Raw Water Storage & Delivery**

As of June 1, 2023, all reservoirs were filled and to the top of the batter boards. The total water currently stored between Clementia, Chesbro, and Calero totaled 4,755 acre-ft (1549 MG).

As of June 1, 2023, we have pumped about 1983.5 acre-ft (646.3 MG) from Cosumnes River this pumping season.

Table 1. Current water and wastewater storage comparison from 2022 - 2023

	May 2023		May 2022		difference from 2022	%diff
	mgal	acre-ft	mgal	acre-ft		
<b>Clementia Storage</b>	341.11	1046.90	290.10	890.4	156.5	15% more
<b>Chesbro Storage</b>	372.38	1142.97	334.61	1027.03	115.9	10% more
<b>Calero Storage</b>	835.78	2565.30	835.78	2565.30	0	0
<b>Total of all Raw Water Reservoirs</b>	<b>1,549.27</b>	<b>4,755.17</b>	<b>1,461.49</b>	<b>4,482.73</b>	<b>272.44</b>	<b>6% more</b>
<b>Wastewater Storage Reservoir available for production</b>	138.0	423.4	136.0	418.4	5.0	1.2%

Figure 1. Five-year Chesbro / Calero Storage Curves

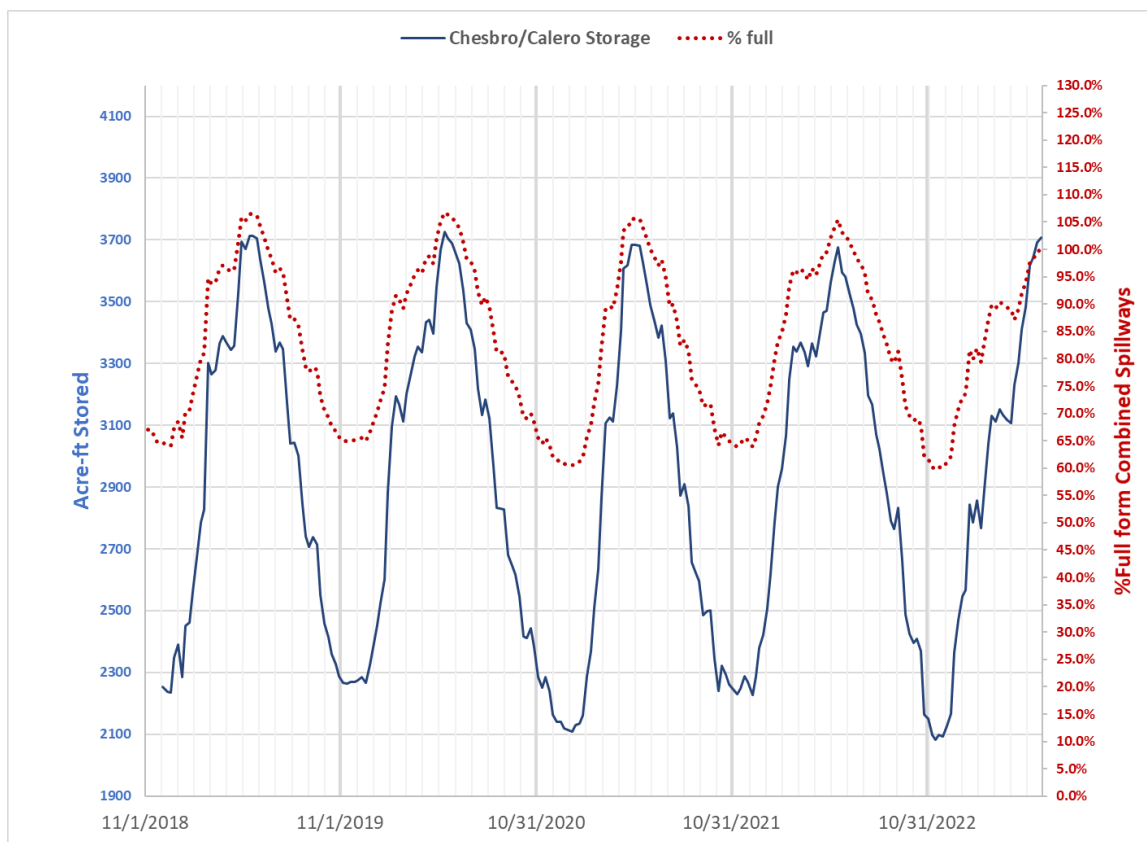

Figure 2. Five-year Clementia Storage Curves

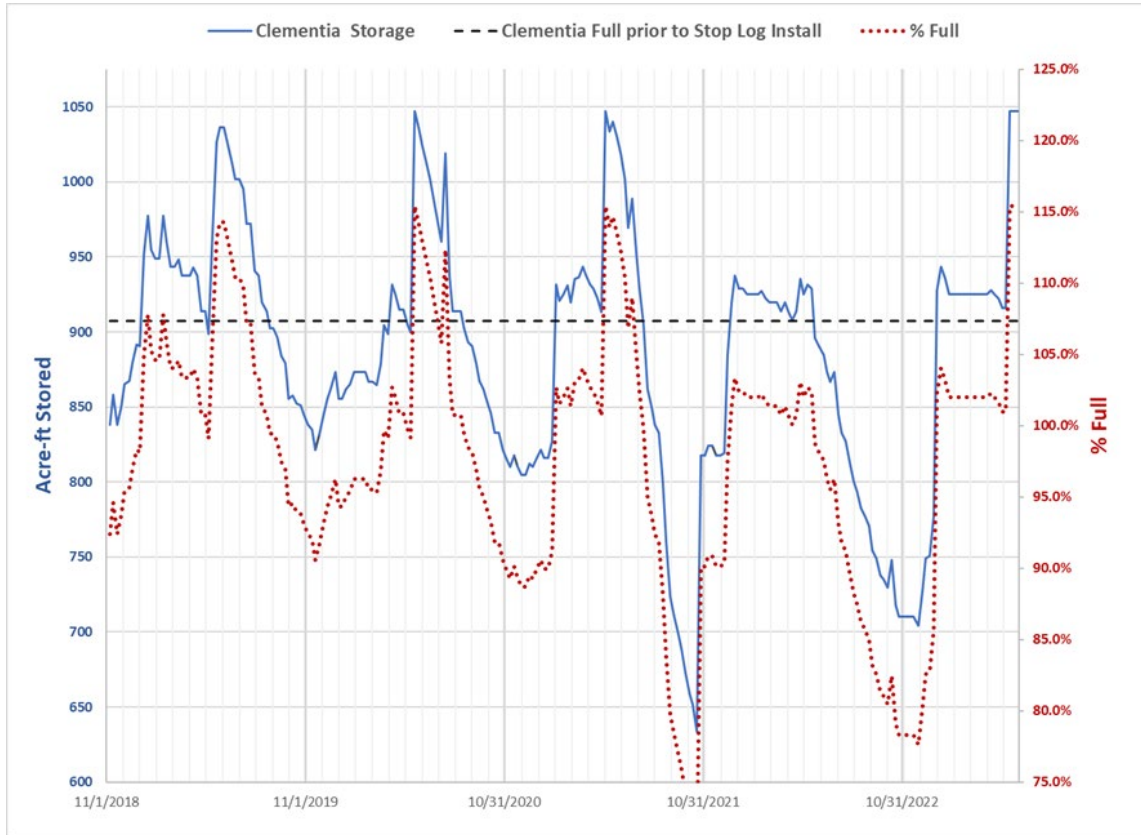
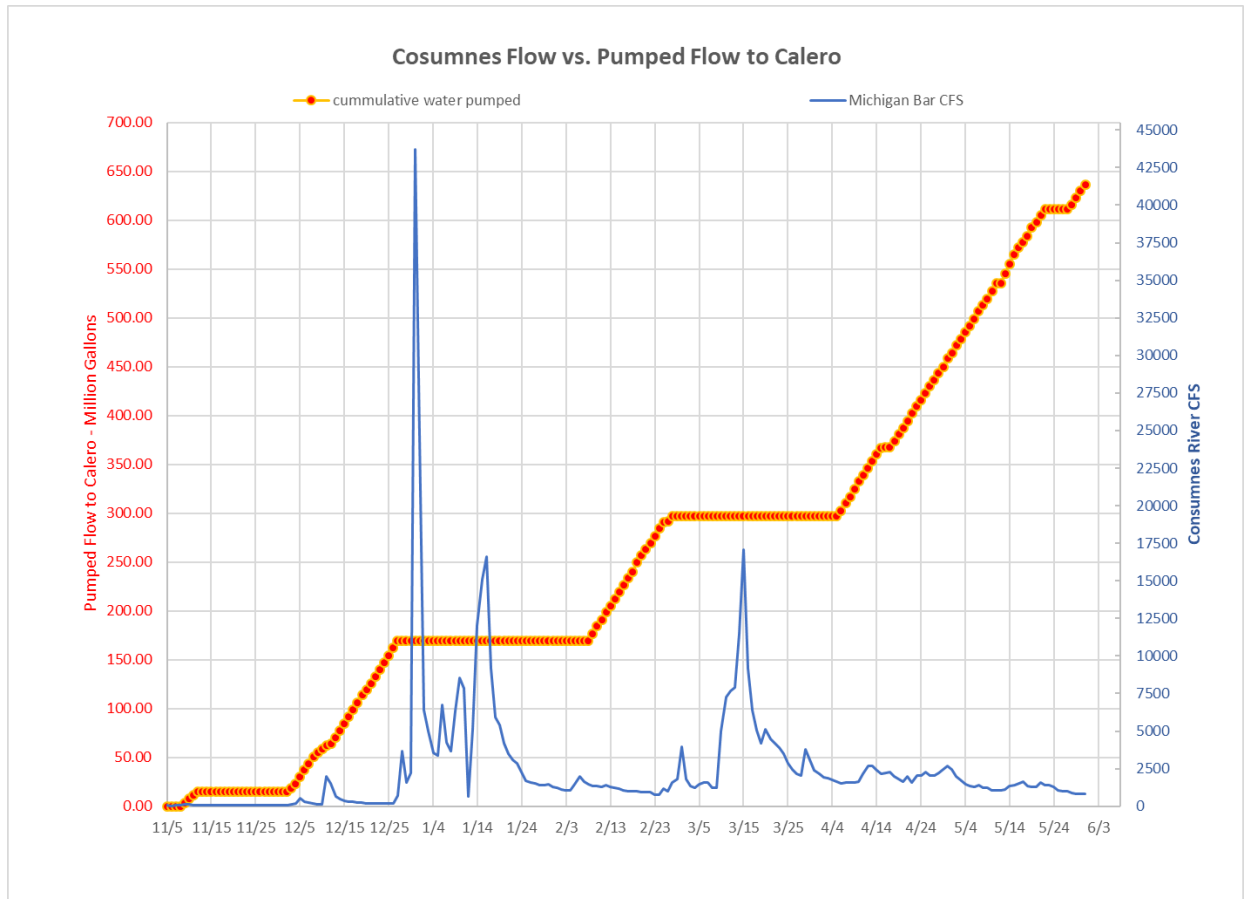

Figure 3. Cosumnes River Flow vs Cumulative Gallons pumped to Calero



## SEWER

### Wastewater Facility

The tertiary process of the wastewater facility is currently on-line and producing about 2 MGD. The current average dry weather influent to the wastewater facility for April was 0.477 MGD and May was 0.422 MGD.

**NOTE:** On 5/31/23, the district had a chlorine leak at the wastewater facility. The fire department was called out and by the time they got here, the leak was already stopped and contained. There was 1 minor injury to an employee, who inhaled a small portion of the gas. The employee was taken to Concentra for evaluation and was released. An investigation was conducted on the ton container, which showed no defects with the cylinder. Based on the incident report received from staff, staff followed the current standard operating procedure (SOP) related to the proper procedure in changing a ton container. This issue and potential changes to the SOP to prevent this type of accident will be addressed in the after-action report. The district is in the process of updating the Process Safety Manual which will address any potential defects in the chlorine gas SOP.



## **UTILITY**

### **Utility Crew Report April & May 2023**

- 1) The Utility Crew had three utility star work order completed. Utility Star work orders are for final reads, rebates, meter swaps request, issues with homeowner water usage concerns and they are doing water shut offs once again.
- 2) The Utility Crew had 30 field markings for 811 USA locations completed.
- 3) The Utility Crew had nine homeowner calls for water related issues; all of them were homeowners with water leaks that is their responsibility to repair, and they were notified.
- 4) The Utility Crew had four water leaks in the month of April & May, they were all service line leaks that were repaired or replaced.
- 5) Several valves were exercised and a total of 11,000 gallons of water flushed through fire hydrants and or blow-offs.
- 6) Nine water meters were replaced in April.
- 7) Four Smart points/ MXU's were replaced in March.
- 8) The Utility Crew had one sewer issue on Alameda street. The sewer line was clogged and had a minor spill of about 840 gallons due to grease. This line is being added to the list to flush more frequently and investigations on the source and frequency of the grease getting into the sewer line have been initiated.
- 9) Utilities staff jetted/cleaned 6,508 feet of sewer main lines between Rancho Murieta North and South as preventative maintenance.

## **CAPITAL PROJECTS**

### **Granlees Safety Project**

This project is currently in the design phase.

### **Water Treatment Facility Chlorine Gas to Sodium Hypochlorite**

This project is at the 100% design completion level, the District will review the 100% design and the resulting updated opinion of probable construction cost. The next step will be to put the project out to bid.

### **Integrated Water Master Plan**

The consultant team will be publishing a story map of the background information from the initial study efforts soon. The next steps of the project are to complete hydraulic modeling, infrastructure investigation, and to select alternatives to investigate.

### **Wastewater Facility Chlorine Gas to Sodium Hypochlorite and Contact Tank Project**

The consultant is completing the preliminary design technical memorandums and will be beginning the 30% design soon. Next steps will be review of the 30% design.

### **Lift Stations (No change or update since last month)**

**Lift 3B** - Pumps have been delivered and are ready for installation. The project has been put out to bid and the District expects to receive bids by July 13, 2023.

**Alameda & Starter Shack Stations** – This project is currently in the design phase

**Cantova & FAA Stations** – The District has contracted with the District Engineer for electrical engineering related to generator sizing and design. The District will also evaluate options for proper maintenance access to the FAA lift station. This project is now in the design phase.

**Lift 6B** – KHOV has begun the electrical work at Lift 6B, the updated pumps and equipment have yet to be received by the contractor.

# Rancho Murieta Community Services District

## July 2023

### Board/Committee Meeting Schedule

**July 5, 2023**

Improvements

**8:00 a.m.**

Finance

**10:00 a.m.**

**July 6, 2023**

Communications & Technology

**8:30 a.m.**

Security

**10:00 a.m.**

**July 19, 2023**

Regular Board Meeting - Open Session

**5:00 p.m.**



*All meetings will be held in person at the District Office: 15160 Jackson Rd.*

**From:** [Janis Eckard](#)  
**To:** [Melinda Morris](#); [Michael Fritschi](#); [Amelia Wilder](#)  
**Subject:** Board of Directors and GM letter,  
**Date:** Wednesday, June 7, 2023 8:20:00 PM

---

To: Board of Directors, Mimi Morris (General Manager), Michael Fritschi and Lisa Maddas,

Due to seeing and hearing conflicting information, additional research was completed. Here are my findings:

Recycled water claims verses facts.

At the March 18th CSD water study meeting, a Power Point presentation showed the Murieta Gardens homes using recycled water. It was stated that the CSD recycled water meets residential landscape usage safety regulations and the developer said they will irrigate with recycled water to reduce the impact their future homes have on the community's water supply.

\*Facts:

- 1) Both The Murieta Gardens and The Retreats have purple pipe in place, but are NOT using recycled water.
- 2) The CSD Treatment Plant produces recycled water that meets residential safety standards, PROVIDED samples are taken where the wastewater leaves the plant. However, recycled water, which is currently stored in lakes located on the Rancho Murieta golf course (where it commingles with surface water and local runoff) DOES NOT.
- 3) Recycled water leaving the treatment plant contains excess chlorine. If delivered directly from the plant, it would damage landscape vegetation. As a result, the recycled water must be stored where the chlorine can dissipate prior to delivery. There is no infrastructure in place to safely deliver the recycled water directly from the treatment plant to any developer lots.
- 4) The RMCS D has a contract with the Rancho Murieta Country Club to supply 100% of the golf course's irrigation demand with recycled water, EVEN IN DROUGHT AND LOW WATER YEARS. The Country Club must supplement with potable water, due to INSUFFICIENT recycled wastewater supply, during all but heavy rainfall years.
- 5) The CSD 1991 Water Rights state the primary recycled water disposal will be on the golf courses, public park and maintenance yard. (Houses are not included.) Like golf course water, there are no chlorine or commingling health issues for park water.
- 6) Under normal precipitation conditions, it takes approximately two households potable water usage to generate enough recycled water to irrigate one home. During times of drought, water rationing DECREASES the amount of recycled water generated.

The May 3rd and May 10th River Valley Times CSD meeting coverage discussed the "excess" recycled water and reported a conversation regarding "whether the district would turn on the recycled water for The Retreats and Murieta Gardens ..."

\*Facts:

1) The CSD cannot simply “turn on the recycled water,” until the necessary infrastructure is in place to safely store and transport it.

2) During heavy rainfall years, there is less demand for recycled water, creating a temporary storage capacity issue. The Van Vleck spray field is used to dispose of excess recycled water, during these times.

For all the above facts/reasons, it is highly unlikely there will ever be sufficient recycled water to supplement future development and reduce the strain these homes will place on Rancho Murieta’s precious water supply.

\*All facts were found in Department of Public Health letters, CSD documents or provided by CSD staff.

Janis Eckard

## Amelia Wilder

---

**From:** Richard Gehrs <rgehrs@outlook.com>  
**Sent:** Wednesday, June 14, 2023 1:52 PM  
**To:** Randy Jenco; Linda Butler; Tim Maybee; Stephen Booth; Martin Pohll; Melinda Morris; Susan Wren  
**Cc:** Amelia Wilder  
**Subject:** Comment on Response to Grand Jury Report

I'd like to respond to one glaring inaccuracy that I see in the draft "RANCHO MURIETA COMMUNITY DISTRICT REPORT TO THE COMMUNITY" which has been posted on the CSD website.

The board's response to Finding #9 (starting on page 9 of the pdf file) contains some glaring inaccuracies and/or distortions of the history of CSD's funding of Security.

The response seems to suggest that prior boards were somehow negligent in not raising the security tax. It said "The first several years the then current RMCSO Board of directors did not even approve the additional tax revenues to be collected." (Measure J was approved in 1998.) Then it immediately says, "The cap of 2% increase as stated by then Board president would never keep up with the cost of security." (It's noteworthy that the 'then board president' is not identified nor does it tell us when that statement was made.)

The fact is that Security was always fully funded by the security tax in EVERY fiscal year prior to FY 2015/16. In the years in which the security tax was not increased there was no need to increase it. The board created the budget and there was no need to increase the tax to fund it. (I suspect that this was, in part, due to the fact that there were more properties paying the tax.) They 'did not even approve the additional tax revenues' (in the word's of the board's response to the Grand Jury') because it wasn't needed.

It wasn't until years later that security costs started accelerating at a rate that the 2% increase 'would never keep up with the cost of security'.

And it should be noted that the allowed 2% increase in the tax accumulates each year, so that even if the tax isn't increased in any year then it can be increased by that 2% in the next year along with another 2%. The 2% increase applies to a maximum permissible amount of the tax. Regardless of whether or not the actual tax is increased in any given year, the maximum permissible amount is increased by 2% each year and accumulates.

The board's response also says "Over the decades the cost of providing security services have increased well above the cost of 2%. It appears that all prior RMCSO Boards did not attempt to identify appropriate funding levels." That is not in any way true. Prior to Fiscal Year 2015/16, the Security tax along with its permissible 2% annual increase fully funded security in every year. The transfer of property tax money to security didn't start until FY 2015/16 with a budgeted transfer of \$65,040. Below is a list of all budgeted transfers of property tax to security:

FY 2014/15: \$0  
FY 2015/16: \$65,040  
FY 2016/17: \$65,040  
FY 2017/18: \$65,040  
FY 2018/19: \$245,000  
FY 2019/20: \$245,000  
FY 2020/21: \$469,452  
FY 2021/22: \$452,516  
FY 2022/23: \$414,591

"All prior RMCS D Boards" weren't as negligent as this response tries to paint them.

Frankly, it appears to me that this response is a deliberate attempt to paint all prior boards as negligent and the current board as a 'white knight' that has come along to save us. That is not true. The Grand Jury says that the board "has lost the trust of the community". I think this response provides a little insight into why that has happened. What we need is openness, honesty, candor, and transparency.

-- Richard Gehrs



# Rancho Murieta Community Services District

FY 2023-24

Proposed Budget







## RANCHO MURIETA COMMUNITY SERVICES DISTRICT

15160 JACKSON ROAD  
RANCHO MURIETA, CALIFORNIA 95683  
916-354-3700  
FAX – 916-354-2082  
[www.rmcsd.com](http://www.rmcsd.com)

*“Your Independent Local Government Agency Providing  
Water, Wastewater, Drainage, Security, and Solid Waste Services”*

---

### BOARD MEMBERS

Tim Maybee	President
Martin Pohll	Vice President
Linda Butler	Director
Randy Jenco	Director
Stephen Booth	Director

---

### STAFF

Mimi Morris	General Manager
Michael Fritschi	Director of Operations
Andrew Ramos	District General Counsel
Amelia Wilder	District Secretary
Kelly Benitez	Security Supervisor
Travis Bohannon	Operations Supervisor

# TABLE OF CONTENTS

## INTRODUCTORY SECTION

Budget Memo.....	2
RMCS D Information Sheet.....	5
FY 2023-24 Rate Adoption Ordinance O2023-03 .....	9
Fy 2023-24 Budget Adoption Resolution R2023-08.....	10

## ORGANIZATIONAL SUMMARY

Organizational Chart .....	15
Personnel Listing.....	16

## FISCAL YEAR 2023-24 BUDGET OVERVIEW

Budget Summary .....	17
Chart Budget Revenue.....	18
Chart Budget Expenditure .....	19
Administration Fund Budget .....	20
Water Fund Budget .....	22
Wastewater Fund Budget .....	23
Drainage Fund Budget .....	24
Solid Waste Fund Budget .....	25
Security Fund Budget .....	26

## FISCAL YEAR 2023-24 RATES AND FEE SCHEDULE

Rates and Fee Schedule.....	27
-----------------------------	----

## CAPITAL IMPROVEMENT PLAN

Capital Improvement Plan.....	30
Capital Improvement Projects Summary.....	31
Water Projects.....	32
Wastewater Projects.....	40
Security Projects.....	48



# Rancho Murieta Community Services District

15160 Jackson Road • P.O. Box 1050 Rancho Murieta, CA 95683 • 916-354-3700 • Fax 916-354-2082

Visit our website [www.rmcsd.com](http://www.rmcsd.com)

June 7, 2023

Rancho Murieta Community Service District Board of Directors

## **BUDGET MESSAGE**

Guided by the Rancho Murieta Community District (RMCS D) Board's vision and direction, we are pleased to present the General Manager's recommended Fiscal Year (FY) 2023-24 Annual Budget. Of primary concern in the coming year will be to develop a strategic roadmap for infrastructure maintenance and improvements to meet the needs of a growing community and to implement best management practices for financial and administrative activities.

The budget process begins with a public hearing and ends with a Board action to adopt the Budget. The District is required to submit a notice to the residents and commercial businesses in Rancho Murieta at least forty-five days before the first reading of the budget by the Board. For Fiscal Year 2023-24, the rate increase notification was authorized by the Board on March 27, 2023, at a Special Board meeting and subsequently mailed to rate payers. Two residents filed objections to the rate increase, which does not meet the threshold required to suspend proposed increases.

## **REVENUES**

The focus of this budget is to address the priorities of the Board and community while being mindful of fiscal and operational stability. The budget is prepared in a way that is different from prior years because management has taken a holistic approach and is presenting all revenues received by the District, whether restricted for a particular purpose or not. In past years, revenues collected but subject to restriction were not included in the budget. Similarly, some uses were not previously included, but are now included in the budget.

The proposed budget reflects estimated revenues of just over \$10.9 million, which is a 33%, or \$2.7 million increase over the prior year. Of that amount \$1.6 million is due to the inclusion of restricted revenues and \$1.1 million is from rate increases across all lines of service. Detailed information on the rate increases can be found in the rate change section of the budget document.

A portion of the Sacramento County property tax revenue is received by the District and is used as a discretionary resource for priorities set by the Board. Significant portions of this tax revenue had been utilized in recent years to offset costs for security services that exceeded security service fees. For FY2023-24, the Security Fund will receive a much lower appropriation of the District's discretionary revenue while capital project appropriations will increase.

## **USES OF RESOURCES**

Uses of Resources are budgeted at \$11.3 million which is an increase of \$3.1 million or 38% over the prior year. \$1.9 million of the increase is due to the inclusion of items funded with restricted revenue, \$425,000 is for water rate and master plan studies, and the remaining \$675,000 is for price increases for chemicals, wages and the solid waste contract.

*Serving the Community for over 30 years*

Board of Directors: Tim Maybee, President • Martin Pohll, Vice-President • Randy Jenco • Linda Butler • Martin Pohll • Stephen Booth  
General Manager • Mimi Morris

## **STRATEGIC OBJECTIVES**

Issues currently affecting the utilities industry in general create pressure on the RMCS D, such as renewal and replacement of aging infrastructure, financing for capital improvements, long term water supply availability and emergency preparedness. District staff met with Board members, committees, staff and stakeholders during the year and have developed objectives for the upcoming year to guide courses of action to focus on infrastructure and fiscal competency.

RMCS D has five core service areas, each with their own fund (**Drainage, Security, Solid Waste, Wastewater, and Water**).

### **DRAINAGE**

**Drainage** revenues are insufficient to fully cover anticipated expenses so the Drainage Fund is budgeted to receive a \$60,000 appropriation of the District discretionary property tax revenue which will leave the fund with a small projected deficit. Costs have increased in recent years due to deferred maintenance and aging infrastructure.

### **SECURITY**

**Security** revenues are insufficient to fully cover security expenses, despite elimination of vacant positions, so the Security Fund is budgeted to receive a \$50,000 appropriation of the District discretionary property tax revenue. This will leave the fund with a deficit for the year of \$250,000 and an overall fund deficit of \$600,000. The deficit is a result of providing service in excess of security service fees over the course of several years. Service levels and staffing have been reduced in the proposed budget by \$184,082 from the prior year and marks a gradual withdrawal of resources beyond what is available based on anticipated security service fees. Administrative revenue support of Security will decline further in FY 2024-25, in order to ensure that services match available security service fee revenue. Research is in process to identify service alternatives that might result in budgetary savings.

### **SOLID WASTE**

Increases in **Solid Waste** costs for FY 2023-24 are significant because they reflect the State of California laws imposed on recycling and solid waste. Revenue is expected to increase \$455,334 and expenditures \$362,145.

The District contracts with California Waste Management (Cal-Waste) to provide garbage collection and recycling services. Revenues collected pay the cost of the contract with the vendor, the fees charged by Sacramento County, insurance and administrative costs of customer service, billing, accounting and governance.

### **WATER**

The **Water** revenues are the most significant revenue source for the District and include residential and commercial fees, connection permits, capital reserve and debt service fees, and investment income. Water revenues are expected to increase \$175,828 for rate increases and the connection of new properties and \$1.2 million of the revenue increase is restricted for capital reserves and reflects the current presentation model.

Water expenditures net of capital transfers are budgeted at \$3.0 million, an increase of \$1.0 million. That difference reflects increases in chemical and labor costs, \$425,000 for master plan and rate studies, and \$159,621 for debt service.

### **WASTEWATER**

**Wastewater** revenues are projected to increase \$891,022, of which \$606,699 is restricted for capital reserves and reflects the current presentation model, and \$284,323 are primarily from rate increases and revenue for new property connections. Uses and expense increases total \$2.3 million and include recording \$889,699 for restrictions, and an increase in operating costs of \$20,167.

### **ADMINISTRATION**

The **Administration** Fund is used as a General Fund for the District. Revenues from property taxes and expenditures for administration, finance and governance are recorded in the Administrative Fund and revenues are appropriated and expenditures are allocated to the five-service area operating funds. A \$43,000 increase is expected from property tax receipts in the Administrative Fund. Expenditures are projected to increase \$68,522, mainly due to pension and benefits costs.

## SHORTFALLS

Operations are expected to result in deficits in four of the five service area operating funds: Drainage, Security, Solid Waste and Water funds. The Waste Fund is estimated to have sufficient available fund balance to absorb the FY 2023-24 shortfall. Actual results from operations in prior years (Beginning Balances) are pending. Once received, more accurate calculations of fund balances will be prepared and plans to eliminate any remaining fund deficits can be created.

## SUMMARY

Staff recommend the Board waive the first reading of Ordinance O2023 -03, to raise the rates for Water, Wastewater, and Solid Waste and the Special Drainage and Security taxes, and Resolution R2023-08, to adopt the FY 2023-24 Budget and move them to the June 21, 2023 Board meeting for a second reading for formal adoption.

## ASSUMPTIONS USED IN THIS PROPOSED BUDGET

1. Revenue estimates are based on the rate schedules presented to the Board on March 27, 2023.
2. Connection fee revenue is based on 60 residential applications being issued during the fiscal year.
3. The number of water distribution system leaks is increasing as a result of deferred capital repair.
4. Sacramento County property tax allocation is projected to increase using the same appraisal values from 2022 to 2023 for home sales.

## FINANCIAL POLICIES

**Basis of Accounting** – The District is a governmental entity and operates on a fiscal year from July 1, through June 30. Accounting records are maintained using the full accrual basis of accounting where revenues are recognized when earned and expenses when incurred. The budget is prepared on a budgetary basis, which differs slightly from financial reporting basis in that the budget does not include amounts for depreciation expense. This budget is used as a management tool for projecting and measuring revenues and expenses.

**Budgetary Control** – The budget is prepared at a detailed level and reported at a summarized level. Since the budget is an estimate, it may be necessary to make adjustments to line items during the course of the year. Various levels of budgetary control have been established to maintain budget integrity. The General Manager has the authority to transfer appropriation balances between budget line items for operations within Funds. Any increases in total appropriations require approval by the Board of Directors.

**Reserve Policy** – The District holds reserves for replacement and major repair of facilities and equipment to minimize adverse annual budgetary impacts from anticipated and unanticipated District expenses.

**Investment Policy** – The District invests public funds in a manner which will provide the highest investment return with the maximum security in conformance with all state and local statutes governing the investment of public funds. In accordance with Section 53600 et. seq. of the State of California Government Code, the authority to invest public funds is expressly delegated to the Board of Directors for subsequent re-delegation to the General Manager acting as the District Treasurer.

**Capital Improvement Program** – The District's annual Capital Improvement Program (CIP) is a projection of the District's capital funding for planned capital projects in upcoming fiscal years. The CIP is reviewed and updated annually and is used for water rate studies, water master planning and infrastructure repair and replacement. A water rate study is included in the FY 2023-24 Budget and will recommend appropriate user charges to meet operational and capital needs.

Respectfully Submitted,



Mimi Morris

General Manager



# Rancho Murieta Community Services District Information Sheet

## ***Mission Statement***

The mission of Rancho Murieta Community Services District is to take a leadership role in responding to the needs of the residents. The District will deliver superior community services efficiently and professionally at a reasonable cost while responding to and sustaining the enhanced quality of life the community desires.

## ***Purpose***

The Rancho Murieta Community Services District (CSD) was formed in 1982 by State Government Code 61000 to provide essential services in Rancho Murieta. The District provides the following services:

- Security
- Water supply collection, treatment, and distribution
- Wastewater collection, treatment, and reuse
- Storm drainage collection and disposal
- Solid waste collection

The District encompasses 3,500 acres, five and a half square miles. Land uses included in the approved master plan call for residential development on 1,981 acres of single-family residences, townhouses, apartments, and mobile homes for a total of 5,189 units. Current estimates indicate Rancho Murieta has over 2,800 households with a population of over 5,900 persons. The District currently maintains over \$56,000,000 in plant, property, and equipment assets.

## ***Population***

Highlights from the Census 2020 demographic profiles show total population in Rancho Murieta at 5,903. The average household size is 2.48. Current estimates indicate Rancho Murieta has 2,369 households with a population of over 5,900.

## ***Latent Powers***

In June of 1982, after local registered voters petitioned the County and public hearings were held, the voters approved the formation of the Rancho Murieta Community Services District (CSD or District), and elected five directors. While the election resulted in voter approval for CSD to provide the following services:

Police protection/security services, road construction and maintenance, landscape maintenance, drainage construction and maintenance, public recreation and street lighting.

Subsequently, the voters authorized the CSD to provide all municipal services authorized in the California Government Code, as well as some special services authorized by the legislature. Those services approved by the voters of Rancho Murieta include:

Fire protection, ambulance, libraries, mosquito abatement, airports, garbage or refuse, transportation services, water and sewer, conversion of existing overhead electric and communication facilities to underground locations, construction improvements of bridges, culverts, curbs, gutters, drains and works incidental to road construction and maintenance.

Later special legislation expanded the District's latent powers to include:

Television and television related services, burglar, and fire alarm facilities, issuance of revenue bonds, enforcement of CC&R's (Covenants, Conditions, and Restrictions), hydroelectric power generating facilities and transmission lines.

While the District has the authority to provide all of these services, at this time, CSD only provides Water, Sewer, Drainage, Security and Solid Waste services.

## ***Security***

Two of the most important reasons for living in Rancho Murieta are the privacy and security. Entrances into the private residential areas have automated access lanes for residents and managed access lanes for visitors.

## ***Water Source and Storage***

The source of water for all uses is primarily the Cosumnes River plus some direct rainfall into reservoir watersheds. State water rights permit diversion for municipal usage only during winter and spring months. Raw water is diverted from the river at Granlees Dam and pumped into reservoirs Calero, Chesbro, and Clementia.

## ***Water Treatment and Distribution***

Raw water, primarily from reservoirs Calero and Chesbro, is treated to potable standards at a treatment plant located at the north end of Clementia reservoir.

## ***Wastewater Collection, Storage, and Reuse***

Imposed at the formation of Rancho Murieta, state regulations prohibit any discharge of wastewater into the Cosumnes River. Regulations require treated wastewater to be used for irrigation of golf courses, parks, and common areas.

When needed for irrigation, the stored, partially treated wastewater is processed through a state-of-the-art tertiary system. The golf courses use this treated effluent to supplement and/or replace raw river water and to reduce wastewater reservoir levels.



## ***Storm Drainage***

Storm water and irrigation runoff is collected in the drainage system throughout the community. A major component of Rancho Murieta's storm drainage system is the extensive amount of natural swales, streams, and tributaries. Runoff is filtered through detention ponds prior to being returned to the Cosumnes River. In addition, the District maintains levees that protect the low-lying areas from flooding.

## ***Solid Waste***

In 2005 Rancho Murieta CSD added Solid Waste Disposal to the services it provides for the community. Under a 10-year contract with Rancho Murieta CSD, California Waste Recovery Systems provides waste disposal services to residents of Rancho Murieta. These now include compliance with SB 1383, Organic Waste Management.

## ***Governance***

The affairs of the District are directed by a five-member Board of Directors elected at large by the registered voters residing in the District. The people who are elected are residents and have the same concerns as residents. The board members serve four-year staggered terms. The District board is responsible, among other things, for passing ordinances, adopting the budget, appointing committees, and hiring the District's General Manager. The District's manager is responsible for carrying out the policies and ordinances of the District board, for overseeing the day-to-day operations of the District, and for appointing the heads for the various departments.

All business of the District is conducted at regular, monthly meetings of the Board. These regular meetings are held the third Wednesday of every month at the District Office located at 15160 Jackson Road with the public session starting at 5:00 p.m. All meetings are open to the public.

## ***Long Term Financial Planning***

The District currently maintains over \$56,000,000 in plant, property, and equipment assets. The District's Reserve Policy 2012-07 is a financial policy guided by sound accounting principles of public fund management. The policy establishes several reserve funds to minimize adverse annual budgetary impacts from anticipated and unanticipated District expenses.

The following reserves are covered under the policy:

- Capital Replacement Fee Reserve (Water, Sewer and Security) – fees are collected for the future replacement of existing facilities and major equipment
- Capital Improvement Fee Reserve – provide funds for the orderly and timely expansion of the District's facilities to meet future demand and to maintain and/or improve the District's existing level of service
- Water Augmentation Fee Reserve – provides funds for the orderly and timely expansion of the District's water supply system to meet future demands of the undeveloped lands within the District's existing boundaries during an equivalent 1976-77 drought event
- Capital Improvement Connection Fee Reserve (Water and Sewer) - fees previously collected as a primary source of funds for the development of additional water and wastewater capacity and is set at a level which will defray the costs of providing additional: treatment and/or reclamation facilities, major trunk and transmission pipelines and facilities for pumping when such facilities are needed
- Rate Stabilization Fund Reserve (Water, Sewer and Security) – offsets revenue shortages due to economic hardships and/or unforeseen major expenses



## ***Cash Management Policies and Practices***

The District's Investment Policy 2016-01 is a conservative policy guided by three principles of public fund management. In specific order of importance the three principles are:

- 1) Safety of Principal. Investments shall be undertaken in a manner which first seeks to preserve portfolio principal.
- 2) Liquidity. Investments shall be made with maturity dates that are compatible with cash flow requirements and which will permit easy and rapid conversion into cash, at all times, without a substantial loss of value.
- 3) Return on Investment. Investments shall be undertaken to produce an acceptable rate of return after first consideration for principal and liquidity.

Investments are accounted for in accordance with the provisions of GASB Statement No. 31, which requires governmental entities to report certain investments at fair value in the balance sheet and recognize the corresponding change in fair value of investments in the year in which the change occurred. The District reports its investments at fair value based on quoted market information obtained from fiscal agents or other sources.

## ORDINANCE NO. O2023-03

### **AN ORDINANCE OF THE BOARD OF DIRECTORS OF THE RANCHO MURIETA COMMUNITY SERVICES DISTRICT, AMENDING CHAPTER 14 OF THE DISTRICT CODE, RELATING TO WATER SERVICE CHARGES; AMENDING CHAPTER 15 OF THE DISTRICT CODE RELATING TO SEWER SERVICE CHARGES; AMENDING CHAPTER 16A OF THE DISTRICT CODE RELATING TO DRAINAGE SPECIAL TAX; AMENDING CHAPTER 21 OF THE DISTRICT CODE RELATING TO SECURITY SPECIAL TAX; AND AMENDING CHAPTER 31 OF THE DISTRICT CODE RELATING TO SOLID WASTE COLLECTION AND DISPOSAL SERVICE CHARGES AND LEAF COLLECTION**

The Board of Directors of the Rancho Murieta Community Services District ordains as follows:

SECTION 1. Purpose and Authority. The purposes of this ordinance are to (a) increase the District water, sewer and solid waste collection and disposal service charges in order to reflect and provide for operation, maintenance and other cost increases due to inflation, increased regulatory costs, increased costs of supplies, services, labor and benefits, and other factors, and (b) increase the District drainage special tax and security special tax to implement the voter-authorized annual adjustments. This ordinance is adopted pursuant to California Constitution articles XIII C, section 2, and XIII D, section 6, Government Code sections 61115, 61121 and 61123, District Ordinances Nos. 98-1 and 98-2, and other applicable law.

SECTION 2. Findings. The Board of Directors finds and determines as follows:

- (a) As calculated and demonstrated in the FY 2023-24 District budget, the increased service charges implemented by this ordinance have been fixed in amounts sufficient to pay the operating expenses of the District's water, sewer and solid waste operations, provide for and fund repairs and replacement of utility system works and equipment, provide for increased costs of regulatory compliance, fund financial reserves, and pay debt service and other costs.
- (b) The increased service charges are reasonably related to, and do not exceed, the District's cost of providing each of the services.
- (c) The revenues derived from the service charges do not exceed the funds required to provide the services and will not be used for any purpose other than the listed services.
- (d) The amount of the service charges imposed on each customer's parcel does not exceed the proportional cost of the particular service attributable to that parcel.
- (e) The District water, sewer and solid waste services are services that are actually used by and immediately available to the owner of each customer parcel.
- (f) No portion of these service charge increases are imposed for general governmental services.
- (g) As calculated and demonstrated in the FY 2023-24 District budget, the increased drainage and security special taxes implemented by this ordinance have been fixed in amounts as calculated and determined consistent with the annual tax adjustments as set forth in District Code chapters 16A and 21 and as authorized by the voters at the time of the approval of the special taxes.

- (h) The establishment, modification, structuring, restructuring and approval of the service charges and taxes as set forth in this ordinance are necessary and appropriate to continue to meet the District's costs for operation and maintenance, supplies and equipment, financial reserves, and capital replacement needs, and to maintain a satisfactory level of services within the District service area.
- (i) The District Board of Directors has conducted a duly noticed public hearing on the proposed service charge increases in accordance with California Constitution article XIII D, section 6, and the Board did not receive a majority protest against any of the proposed service charge increases.

SECTION 3. Service Charge and Tax Adjustments; District Code Amendments

I) The Water Code, Chapter 14, Section 7.00 Rates and Charges is amended as follows:  
Section 7.05 Rates for Metered Service.

(a) General metered service shall be as follows:

MONTHLY CHARGES

Base Charge	\$ 42.84
Reserve Charge	<u>\$ 14.00</u>
Total Basic Service Charge	\$ 56.84/mo

Usage charge per 100 cubic feet:

Basic volumetric rate per 100 cubic feet	\$ 2.17 per 100 cubic feet
--	----------------------------

(b) Metered service to residential lots at Murieta Village and Murieta Gardens II shall be as follows:

MONTHLY CHARGES

Base Charge	\$ 42.84
Reserve Charge	<u>\$ 14.00</u>
Total Basic Service Charge	\$ 56.84/mo

Usage charge per 100 cubic feet:

Basic volumetric rate per 100 cubic feet	\$ 2.17 per 100 cubic feet
--	----------------------------

(c) Non-Residential metered service shall be as follows:

MONTHLY CHARGES

Basic Service Charge for non-residential shall be calculated on an EDU basis

Monthly Charges

Basic Service Charge for non-residential metered service shall be calculated on number of meters and an EDU basis for each customer multiplied by the Basic Service Charge reflected in Section 7.05(a) above.

Usage charge per 100 cubic feet:

Basic volumetric rate per 100 cubic feet	\$ 2.17 per 100 cubic feet
--	----------------------------

II) The Sewer Code, Chapter 15, Section 7.00 Rates and Charges is amended as follows:

Section 7.03 Rates and Charges for Service. The monthly service charge for each premise receiving sewer service from the District shall be:

Residential or other premises, each unit	
Base rate	\$ 54.12 per month

Reserve contribution	<u>\$ 14.00 per month</u>
Total monthly service charge	\$ 68.12 per month

Murieta Village and Murieta Gardens II, per unit

Base rate	\$ 54.12 per month
Reserve contribution	<u>\$ 14.00 per month</u>
Total monthly service charge	\$ 68.12 per month

Non-Residential

Monthly service charge for non-residential sewer service shall be calculated on an EDU basis for each customer multiplied by the residential service charge rate.

III) The Drainage Code, Chapter 16, Section 7.00 Rates and Charges is amended as follows:

Section 7.01 Rates and Charges: Drainage charges for operation and maintenance of the District's system shall be as set forth in Chapter 16A, Section 3.00.

The Drainage Code, Chapter 16A, Section 3.00 Drainage Tax, is amended as follows:

Section 3.00 Rates and Charges for Operation and Maintenance of the District's system shall be: Commencing July 1, 2023, property within the District shall be assessed a monthly drainage tax as follows. The maximum monthly tax rates shown reflect annual adjustments, per Section 5.00.

LAND USE		Monthly Special Tax Rates Fiscal Year 2023-24	Monthly Special Tax Rates Maximum Ceiling Rate Year 2023-24
<b>DEVELOPED PROPERTY</b>			
Residential			
Metered Developed	Per Lot	\$ 5.64	5.64
Unmetered Developed	Per Lot	\$ 5.64	5.64
The Villas	Per Lot	\$ 3.77	3.77
Murieta Village	Per Lot	\$ 3.77	3.77
Murieta Gardens	Per Lot	\$ 3.77	3.77
Non-Residential			
Retail	Per Acre	\$ 28.24	28.24
Industrial/Warehouse	Per Acre	\$ 30.03	30.03
Light Industrial	Per Acre	\$ 22.96	22.96
Office	Per Acre	\$ 26.49	26.49
Landscaped Areas (golf course & parks)	Per Acre	\$ 5.29	5.29
Murieta Equestrian Center	Per Acre	\$ 2.05	2.05
RMCC (club house & parking)	Per Acre	\$ 0.00	0.00
Airport	Per Acre	\$ 2.37	2.37
Geyer Property	Per Acre	\$ 17.66	17.66
Hotel/Ext Stay		\$ 28.25	28.25

**UNDEVELOPED PROPERTY**

**Uses Drainage System**

-Residential and Non-Residential      Per Acre      \$ 3.34      3.34

IV) The Security Code, Chapter 21, Section 5.00 Security Tax, is amended as follows:

Commencing July 1, 2023, property within the District shall be assessed a monthly security tax as follows. The maximum tax rates shown reflect annual adjustments, per Section 5.00:

LAND USE	Monthly Special Tax Rates Fiscal Year 2023-2024	Monthly Special Tax Rates Maximum Ceiling Rate Year 2023-2024
<b>DEVELOPED PROPERTY</b>		
Residential per lot		
Inside Gates		
<i>Metered</i>	\$ 32.18	32.18
<i>Unmetered</i>	\$ 25.26	25.26
Outside Gate	\$ 7.76	7.76
Non-Residential per building square foot		
<i>Highway Retail</i>	\$ 0.2901	0.2901
<i>Other Retail/Commercial</i>	\$ 0.0312	0.0312
<i>Industrial/Warehouse/Lt Industrial</i>	\$ 0.0682	0.0682
<i>Office</i>	\$ 0.0164	0.0164
<i>Institutional</i>	\$ 0.0164	0.0164
<i>Public Utility</i>	\$ 0.0520	0.0520
<i>Equine Complex</i>	\$ 0.0049	0.0049
<i>RMCC</i>	\$ 0.0817	0.0817
<i>Airport</i>	\$ 0.0208	0.0208
Hotel/Ext. Stay	\$ 0.0312	0.0312
<b>UNDEVELOPED PROPERTY – Per Acre</b>		
Inside Gates	\$ 27.2225	27.2225
Outside Gates	\$ 4.0566	4.0566

V) The Solid Waste Collection and Disposal Code, Chapter 31, Section 4.0 Collection Rates, is amended as follows:

Section 4.03 Collections Rates. The monthly service charge shall be:

(1) Garbage Collection Services	
35-gallon cart	\$ 32.76
65-gallon cart	\$ 38.96
95-gallon cart	\$ 61.33
(2) Additional Garbage Carts	
35-gallon cart	\$ 9.46
65-gallon cart	\$ 12.61

95-gallon cart	\$ 28.98
(3) Additional Recycling Cart (in excess of 1 recycled cart)	
38-gallon cart	N/A
64-gallon cart	\$ 7.80
96-gallon cart	\$ 7.80

(4) Additional Green Waste Cart (in excess of 2 green waste carts)	
38-gallon cart	N/A
64-gallon cart	\$ 7.80
96-gallon cart	\$ 7.80

(5) Sacramento County Surcharge	\$ 3.00
---------------------------------	---------

SECTION 4. Superseder. This ordinance supersedes prior inconsistent District ordinances, resolutions, policies, rules, and regulations concerning the subject matter of this ordinance.

SECTION 5. Effective Date. This ordinance shall take effect on July 1, 2023.

SECTION 6. Severability. If any section or provision of this ordinance or the application of it to any person, transaction or circumstance is held invalid or unenforceable, such invalidity or unenforceability shall not affect the other provisions of this ordinance that can be given effect without the invalid or unenforceable provision, and to this end the provisions of this ordinance are declared to be severable.

SECTION 7. Publication. The District Secretary is directed to publish this ordinance once in a newspaper of general circulation published in the District within 15 days after the adoption of the ordinance.

**INTRODUCED** by the Board of Directors on the 7<sup>th</sup> day of June 2023.

**PASSED AND ADOPTED** by the Board of Directors of the Rancho Murieta Community Services District, Sacramento County, California, at a meeting held on the 21<sup>st</sup> day of June 2023, by the following roll call vote:

**AYES:**

**NOES:**

**ABSENT:**

**ABSTAIN:**

---

Timothy E. Maybee, President of the Board  
Rancho Murieta Community Services District

[seal]

**ATTEST:**

---

Amelia Wilder, District Secretary

**RESOLUTION NO. R2023-08**

**A RESOLUTION OF THE BOARD OF DIRECTORS OF  
THE RANCHO MURIETA COMMUNITY SERVICES DISTRICT  
APPROVING THE BUDGET FOR FISCAL YEAR 2023-24**

**WHEREAS**, District departments have submitted estimates of budget requirements for Fiscal Year 2023-24 and those estimates have been reviewed by the General Manager and Finance Committee; and

**WHEREAS**, the General Manager has submitted a proposed budget with the tabulations of the estimates together with proposed revisions to the Board of Directors; and

**WHEREAS**, the Board of Directors has reviewed and considered the proposed budget for Fiscal Year 2023-24; and

**WHEREAS**, a public presentation and hearing were conducted for the budget for the Fiscal Year 2023-24 on June 7, 2023 at 5:00 p.m. in the Board Room at 15160 Jackson Road, Rancho Murieta, CA 95683.

**NOW, THEREFORE, BE IT RESOLVED AND ORDERED** that (1) the proposed budget for Fiscal Year 2023-24, as submitted by the District General Manager and as reviewed by the Board of Directors is a proper financial program for the budget period and constitutes the budget for 2023-24; and (2) the District's 2023-24 Budget is hereby adopted in the form as presented at this meeting and ordered filed with the County Auditor of Sacramento County in accordance with Sections 53901 and 61110 of the Government Code.

**INTRODUCED** by the Board of Directors on the 7<sup>th</sup> day of June 2023.

**PASSED AND ADOPTED** by the Board of Directors of the Rancho Murieta Community Services District, Sacramento County, California, at a meeting held on the 21<sup>st</sup> day of June 2023, by the following roll call vote:

**AYES:**

**NOES:**

**ABSENT:**

**ABSTAIN:**

---

Timothy E. Maybee, President of the Board  
Rancho Murieta Community Services District

[SEAL]

Attest:

---

Amelia Wilder, District Secretary

**RANCHO MURIETA COMMUNITY SERVICES DISTRICT  
ORGANIZATIONAL CHART**

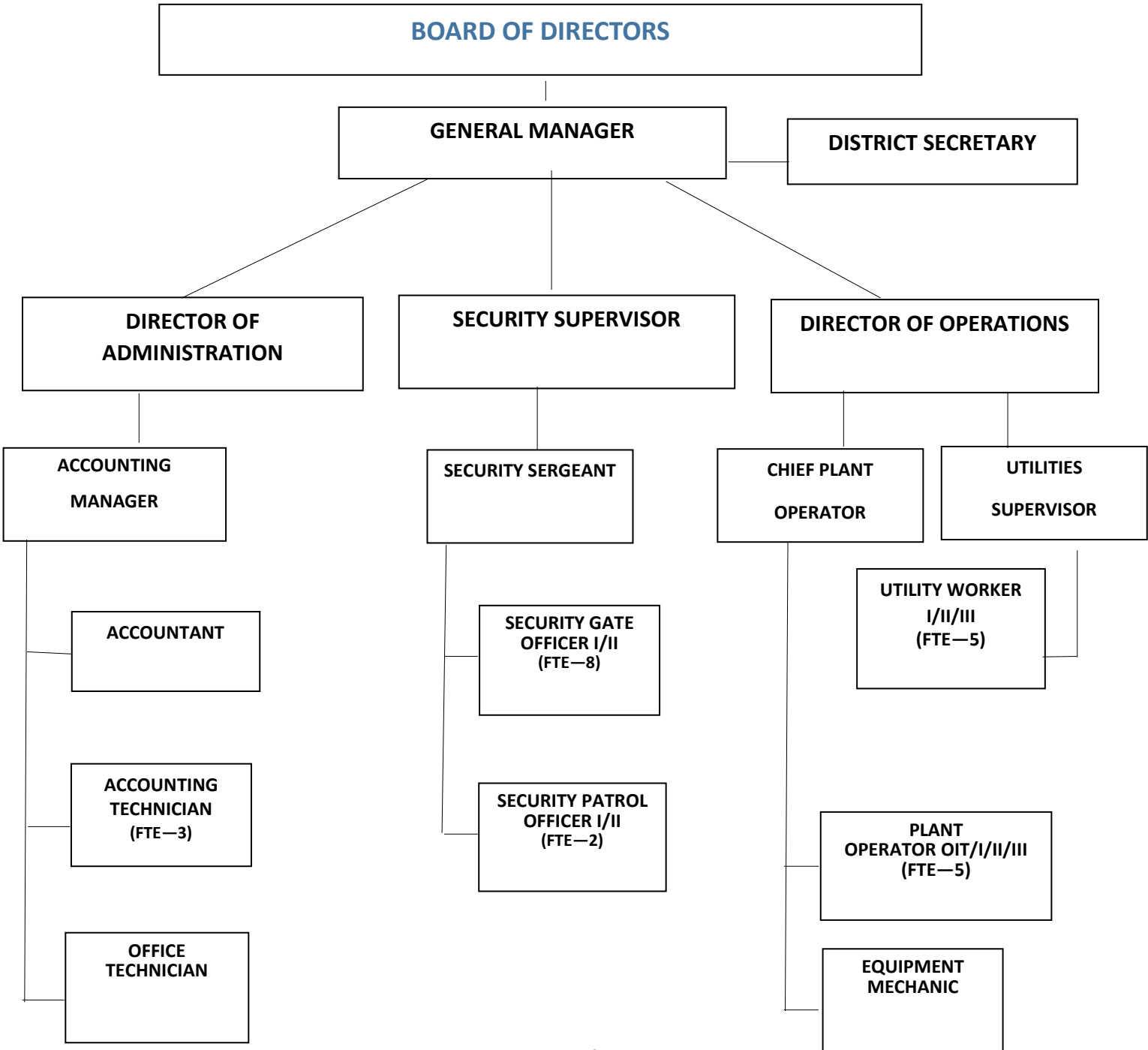





**RANCHO MURIETA COMMUNITY SERVICES DISTRICT**  
**FY 2023-24 Proposed Budget**  
**Personnel Listing**

	FY 2020-21	FY 2021-22	FY 2022-23	FY 2023-24	
	Adopted	Adopted	Budget	Proposed Budget	Change
<b>ADMINISTRATION</b>					
GENERAL MANAGER	1	1	1	1	-
DISTRICT SECRETARY	1	1	1	1	-
DIRECTOR OF ADMINISTRATION	1	1	1	1	-
ACCOUNTING MANAGER	1	1	1	1	-
ACCOUNTANT	1	1	1	1	-
ACCOUNTING TECHNICIAN	1	3	3	3	-
OFFICE TECHNICIAN	1	1	1	1	-
	<b>7</b>	<b>9</b>	<b>9</b>	<b>9</b>	<b>-</b>
<b>OPERATIONS</b>					
DIRECTOR OF OPERATIONS	1	1	1	1	-
CHIEF PLANT OPERATOR	1	1	1	1	-
PLANT OPERATOR I, II, III, OIT	5	5	5	5	-
EQUIPMENT MECHANIC	1	1	1	1	-
UTILITIES SUPERVISOR	1	1	1	1	-
UTILITY WORKER I, II, III	5	5	5	5	-
TEMP UTILITY WORKER	0.5	0.5	0.5	-	(0.5) *
	<b>14.5</b>	<b>14.5</b>	<b>14.5</b>	<b>14.0</b>	<b>(0.5)</b>
<b>SECURITY</b>					
SECURITY SUPERVISOR	1	1	1	1	-
SECURITY SERGEANT	1	1	1	1	-
PATROL OFFICER	5	5	5	2	(3)
GATE OFFICER	8	8	8	8	-
PART-TIME GATE OFFICER	2	2	2	-	(2) *
	<b>17</b>	<b>17</b>	<b>17</b>	<b>12</b>	<b>(5)</b>
<b>TOTAL</b>	<b>38.5</b>	<b>40.5</b>	<b>40.5</b>	<b>35.0</b>	<b>(5.5)</b>

Notes:

\* Position count is for authorized full time positions.

Appropriations for part time wages (if any) are included in the expenditure budget.



**RANCHO MURIETA Community Services District**  
**FY 2023-24 Proposed Budget**  
**Budget Summary**

	FY 2020-21 Budget	FY 2021-22 Budget	FY 2022-23 Budget	FY 2023-24 Proposed Budget	% Change
<b>Revenues</b>					
Administration	722,210	756,290	817,450	860,450	5%
Water	2,507,729	2,634,526	2,905,332	4,271,112	47%
Wastewater	1,513,570	1,660,269	1,703,379	2,594,401	52%
Drainage	217,192	214,916	240,644	240,000	0%
Solid Waste	735,479	986,086	961,093	1,416,427	47%
Security	1,526,347	1,568,266	1,645,217	1,587,960	-3%
<b>Total</b>	<b>7,222,528</b>	<b>7,820,354</b>	<b>8,273,115</b>	<b>10,970,350</b>	<b>33%</b>
<b>Uses of Resources</b>					
Administration	1,825,904	1,976,562	1,977,786	2,046,308	3%
Water	1,816,956	1,895,710	2,076,091	4,054,025	95%
Wastewater	1,248,848	1,159,843	1,372,539	2,282,405	66%
Drainage	204,778	214,428	247,781	221,694	-11%
Solid Waste	715,708	922,243	1,032,279	1,394,424	35%
Security	1,410,332	1,392,245	1,438,206	1,254,124	-13%
<b>Total</b>	<b>7,222,526</b>	<b>7,561,031</b>	<b>8,144,682</b>	<b>11,252,980</b>	<b>38%</b>
<b>Transfers In</b>					
To Capital Reserve from Admin				283,000	
To Water from Admin	-	-	-	425,000	
To Wastewater from Admin			159,651		
To Drainage from Admin	64,521	82,107	89,783	60,000	
To Solid Waste from Admin	-	-	110,975	-	
To Security from Admin	469,452	452,516	414,591	50,000	
<b>Transfers Out</b>					
From Admin to Capital Reserve				(283,000)	
From Admin to Water	-	-	-	(425,000)	
From Admin to Wastewater			(159,651)		
From Admin to Drainage	(64,521)	(82,107)	(89,783)	(60,000)	
From Admin to Solid Waste	-	-	(110,975)	-	
From Admin to Security	(469,452)	(452,516)	(414,591)	(50,000)	
<b>Administrative Cost Allocation Transfers</b>					
To Admin from Operating Depts.	1,825,904	1,976,562	1,977,786	2,003,858	
From Water to Admin	(679,974)	(736,038)	(744,258)	(745,435)	
From Sewer to Admin	(452,787)	(490,188)	(490,491)	(496,957)	
From Drainage to Admin	(76,299)	(82,595)	(82,646)	(84,162)	
From Solid Waste to Admin	(36,216)	(39,204)	(38,789)	(40,077)	
From Security to Admin	(580,627)	(628,537)	(621,602)	(637,227)	
<b>Total Transfers</b>	<b>-</b>	<b>-</b>	<b>-</b>	<b>-</b>	<b>-</b>



**Rancho Murieta Community Services District  
FY 2023-24 Proposed Budget  
Revenue Summary**

**FY 2023-24 Estimated Revenues**

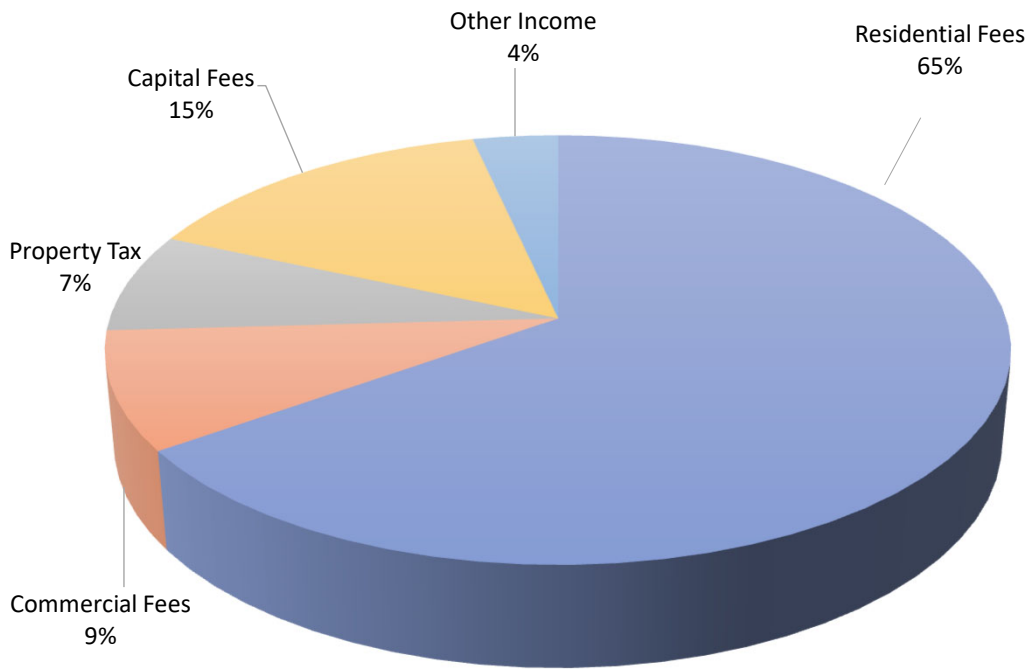

**FY 2023-24 Estimated Revenues - All Funds**

Residential Fees	7,151,819
Commercial Fees	978,610
Property Tax	818,000
Capital Fees	1,637,000
Other Income	384,921
<b>Total</b>	<b><u><u>10,970,350</u></u></b>

\*Estimated revenues exclude interfund transfers



**Rancho Murieta Community Services District  
FY 2023-24 Proposed Budget  
Expenditure Summary**

**FY 2023-24 Proposed Expenditures**

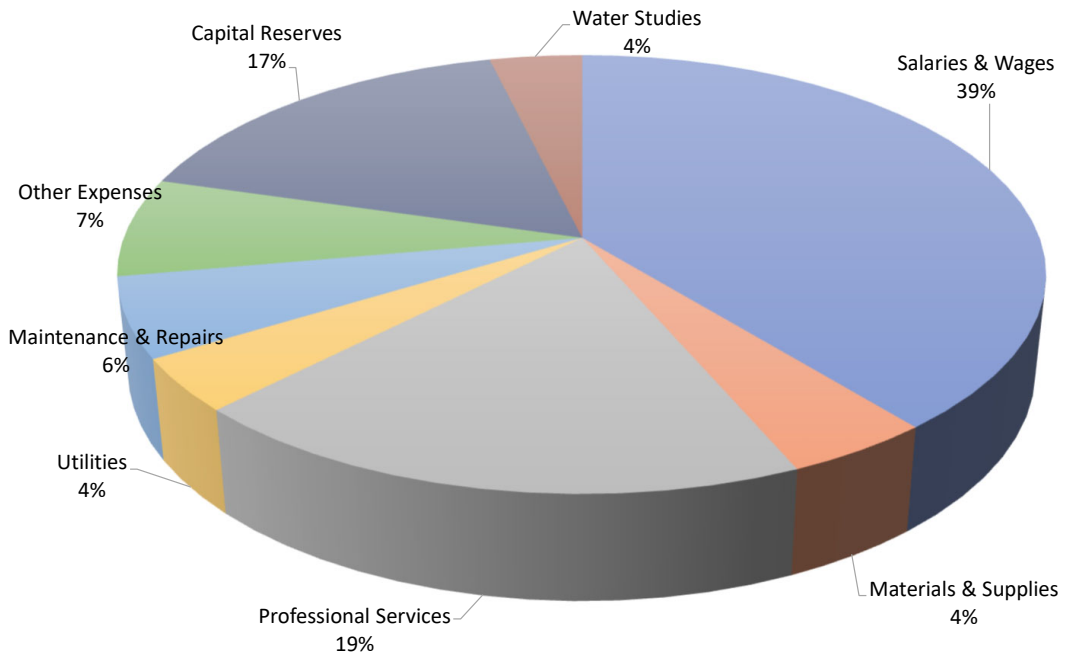

**FY 2023-24 Proposed Expenditures - All Funds**

Salaries & Wages	4,396,924
Materials & Supplies	498,700
Professional Services	2,126,267
Utilities	440,000
Maintenance & Repairs	662,100
Other Expenses	820,738
Capital Reserves	1,883,251
Water Studies	425,000
<b>Total</b>	<b><u><u>11,252,980</u></u></b>

\*Estimated expenditures exclude interfund transfers

**Rancho Murieta Community Services District  
Administration - Fund 100  
FY 2023-24 Proposed Budget**

	<u>FY 2020-21</u> <b>Adopted Budget</b>	<u>FY 2021-22</u> <b>Adopted Budget</b>	<u>FY 2022-23</u> <b>Adopted Budget</b>	<u>FY 2023-24</u> <b>Proposed Budget</b>
<b>Beginning Balance</b>	\$ -	\$ 188,237	\$ 409,904	\$ 452,354
<b>Revenue</b>				
Property Tax	701,750	731,750	775,000	818,000
Interest Income	240	240	450	450
Other Revenues	20,220	24,300	42,000	42,000
<b>Total Revenue</b>	<u>722,210</u>	<u>756,290</u>	<u>817,450</u>	<u>860,450</u>
<b>Expenditures</b>				
Salaries	710,300	802,200	948,800	877,606
Benefits & Pension	470,908	695,575	464,173	570,002
Professional Services	145,600	298,287	403,663	435,000
Materials & Supplies	261,801	61,400	64,750	57,700
Other Expenses	237,295	119,100	96,400	106,000
<b>Total Expenditures</b>	<u>1,825,904</u>	<u>1,976,562</u>	<u>1,977,786</u>	<u>2,046,308</u>
<b>Transfers Out</b>				
To Water - Operations Studies	-	-	-	(425,000)
To Wastewater - Capital Projects	-	-	-	(283,000)
To Wastewater-Debt Service	-	-	(159,651)	-
To Drainage - Operations	(64,521)	(82,107)	(89,783)	(60,000)
To Solid Waste - Operations	-	-	(110,975)	-
To Security - Operations	(469,452)	(452,516)	(414,591)	(50,000)
	<u>(533,973)</u>	<u>(534,623)</u>	<u>(775,000)</u>	<u>(818,000)</u>
<b>Transfers In</b>				
From Water - Cost Allocation	679,974	736,038	744,258	745,435
From Wastewater - Cost Allocation	452,787	490,188	490,491	496,957
From Drainage - Admin Cost Allocation	76,299	82,595	82,646	84,162
From Solid Waste - Admin Cost Allocation	36,216	39,204	38,789	40,077
From Security - Admin Cost Allocation	580,628	628,537	621,602	637,227
	<u>1,825,904</u>	<u>1,976,562</u>	<u>1,977,786</u>	<u>2,003,858</u>
<b>Net Annual Activity</b>	<b>188,237</b>	<b>221,667</b>	<b>42,450</b>	<b>-</b>
<b>Ending Balance</b>	<u><u>\$ 188,237</u></u>	<u><u>\$ 409,904</u></u>	<u><u>\$ 452,354</u></u>	<u><u>\$ 452,354</u></u>

**Rancho Murieta Community Services District  
Water Fund 200  
FY 2023-24 Proposed Budget**

	<u>FY 2020-21</u>	<u>FY 2021-22</u>	<u>FY 2022-23</u>	<u>FY 2023-24</u>
	<u>Adopted</u>	<u>Adopted</u>	<u>Adopted</u>	<u>Proposed</u>
	<u>Budget</u>	<u>Budget</u>	<u>Budget</u>	<u>Budget</u>
<b>Beginning Balance</b>	<b>\$ (1,265,582)</b>	<b>\$ (1,254,783)</b>	<b>\$ (1,252,004)</b>	<b>\$ (1,167,021)</b>
<b>Revenue</b>				
Residential Water Fees	2,167,231	2,229,226	2,490,075	2,567,000
Commercial Water Fees	264,262	329,915	320,737	427,000
Replacement Reserve Fees	-	-	-	449,232
Connection Fees	-	-	-	544,320
Water Plant Debt Service Fee	-	-	-	196,400
State Grant	-	-	-	-
Late Fees & Penalties	15,600	19,200	20,000	10,000
Other Users	8,600	39,600	37,400	8,400
Interest Income	3,800	3,800	3,800	-
Other Revenues	48,236	12,785	33,320	68,760
<b>Total Revenue</b>	<b><u>2,507,729</u></b>	<b><u>2,634,526</u></b>	<b><u>2,905,332</u></b>	<b><u>4,271,112</u></b>
<b>Expenditures - Supervision &amp; Management</b>				
Salaries	182,794	147,940	131,210	176,098
Benefits & Pension	56,950	56,950	59,590	49,226
Professional Services	144,469	133,200	120,000	150,000
Materials & Supplies	19,271	35,455	43,905	48,600
Maintenance & Repairs	25,110	41,820	47,100	60,000
Other Expenses	-	142,005	246,915	242,800
Water Studies	-	46,000	-	425,000
Water Plant Debt	-	-	-	159,651
	<u>428,594</u>	<u>603,370</u>	<u>648,720</u>	<u>1,311,375</u>
<b>Expenditures - Source of Supply</b>				
Salaries	18,344	24,238	24,442	25,220
Benefits & Pension	8,705	11,493	11,919	10,498
Professional Services	-	46,000	47,500	50,000
Materials & Supplies	-	13,500	17,500	27,500
Maintenance & Repairs	30,000	30,000	25,000	40,000
Utilities	84,016	84,025	87,450	93,000
Other Expenses	-	250	-	5,000
	<u>141,064</u>	<u>209,506</u>	<u>213,811</u>	<u>251,218</u>
<b>Expenditures - Water Treatment</b>				
Salaries	188,430	207,924	256,641	284,806
Benefits & Pension	102,602	120,090	125,139	120,934
Professional Services	-	600	-	20,000
Materials & Supplies	93,224	103,200	109,000	155,000
Maintenance & Repairs	208,575	94,000	109,000	150,000
Utilities	121,323	61,348	65,000	140,000
Other Expenses	3,363	4,380	3,500	5,000
	<u>717,517</u>	<u>591,542</u>	<u>668,280</u>	<u>875,740</u>

**Rancho Murieta Community Services District  
Water Fund 200  
FY 2023-24 Proposed Budget**

	<u>FY 2020-21</u>	<u>FY 2021-22</u>	<u>FY 2022-23</u>	<u>FY 2023-24</u>
	<u>Adopted</u>	<u>Adopted</u>	<u>Adopted</u>	<u>Proposed</u>
	<u>Budget</u>	<u>Budget</u>	<u>Budget</u>	<u>Budget</u>
<b>Expenditures - Transmission and Delivery</b>				
Salaries	196,159	207,924	256,641	284,806
Benefits & Pension	97,264	120,090	125,139	105,334
Professional Services	-	-	-	15,000
Materials & Supplies	60,470	51,400	41,500	47,000
Maintenance & Repairs	90,052	70,000	80,000	80,000
Utilities	84,379	41,278	42,000	85,000
Other Expenses	1,457	600	-	5,000
	<u>529,780</u>	<u>491,292</u>	<u>545,280</u>	<u>622,140</u>
<b>Total Expenditures</b>	<b>1,816,956</b>	<b>1,895,710</b>	<b>2,076,091</b>	<b>3,060,473</b>
<b>Transfers Out</b>				
To Admin - Cost Allocation	(679,974)	(736,038)	(744,258)	(745,436)
To Water - Capital Reserves	-	-	-	(993,552)
<b>Transfer In</b>				
From Admin - Tax Appropriation	-	-	-	425,000
<b>Net Annual Activity</b>	<u>10,799</u>	<u>2,778</u>	<u>84,983</u>	<u>(103,349)</u>
<b>Ending Balance</b>	<u><u>\$ (1,254,783)</u></u>	<u><u>\$ (1,252,004)</u></u>	<u><u>\$ (1,167,021)</u></u>	<u><u>\$ (1,270,370)</u></u>

**Rancho Murieta Community Services District**  
**Wastewater Fund 250**  
**FY 2023-24 Proposed Budget**

	<u>FY 2020-21</u>	<u>FY 2021-22</u>	<u>FY 2022-23</u>	<u>FY 2023-24</u>
	<u>Adopted</u>	<u>Adopted</u>	<u>Adopted</u>	<u>Proposed</u>
	<u>Budget</u>	<u>Budget</u>	<u>Budget</u>	<u>Budget</u>
<b>Beginning Balance</b>	\$ 475,676	\$ 287,611	\$ 297,850	\$ 297,850
<b>Revenue</b>				
Residential Wastewater Sales	1,347,259	1,479,998	1,486,937	1,694,592
Commercial Wastewater Sales	141,636	153,192	153,192	228,610
Reserve Contribution	-	-	-	447,048
Late Fees & Penalties	18,000	18,000	18,000	20,000
Other Sales	2,184	2,184	2,250	2,000
Interest Income	2,500	2,500	42,500	42,500
Other Revenues	1,991	4,395	500	-
Loan Proceeds	-	-	-	159,651
<b>Total Revenue</b>	<u>1,513,570</u>	<u>1,660,269</u>	<u>1,703,379</u>	<u>2,594,401</u>
<b>Expenditures - Supervision &amp; Management</b>				
Salaries	39,178	72,264	73,326	75,659
Benefits & Pension	165,656	35,080	34,650	31,361
Professional Services	21,694	42,000	47,000	65,000
Materials & Supplies	32,056	51,625	35,325	41,500
Maintenance & Repairs	71,205	65,837	68,687	75,500
Other Expenses	105,996	57,710	159,876	125,380
	<u>435,786</u>	<u>324,516</u>	<u>418,864</u>	<u>414,400</u>
<b>Expenditures - Collection</b>				
Salaries	54,528	123,616	171,094	176,537
Benefits & Pension	11,919	74,408	80,850	77,155
Professional Services	-	1,200	2,500	3,000
Materials & Supplies	91	1,800	3,100	3,000
Maintenance & Repairs	43,474	120,000	100,000	100,000
Utilities	68,842	63,278	64,000	72,000
	<u>178,854</u>	<u>384,302</u>	<u>421,544</u>	<u>431,692</u>
<b>Expenditures - Treatment</b>				
Salaries	180,045	163,361	211,423	214,367
Benefits & Pension	53,817	95,330	99,908	87,247
Professional Services	4,001	1,200	1,200	2,000
Materials & Supplies	77,414	75,000	76,000	90,000
Maintenance & Repairs	122,202	98,000	98,000	100,000
Utilities	193,329	17,634	45,000	50,000
Other Expenses	3,400	500	600	3,000
	<u>634,208</u>	<u>451,025</u>	<u>532,131</u>	<u>546,614</u>
<b>Total Expenditures</b>	<u>1,248,848</u>	<u>1,159,843</u>	<u>1,372,539</u>	<u>1,392,706</u>
<b>Transfers Out</b>				
To Admin - Cost Allocation	(452,787)	(490,187)	(490,491)	(496,957)
To Wastewater - Capital Reserves	-	-	-	(889,699)
<b>Transfers In</b>				
From Admin - Tax Appropriation	-	-	159,651	283,000
<b>Net Annual Activity</b>	<u>(188,065)</u>	<u>10,239</u>	<u>-</u>	<u>98,039</u>
<b>Ending Balance</b>	<u>\$ 287,611</u>	<u>\$ 297,850</u>	<u>\$ 297,850</u>	<u>\$ 395,889</u>



**Rancho Murieta Community Services District  
Drainage Fund 260  
FY 2023-24 Proposed Budget**

	<u>FY 2020-21</u>	<u>FY 2021-22</u>	<u>FY 2022-23</u>	<u>FY 2023-24</u>
	<u>Adopted</u>	<u>Adopted</u>	<u>Adopted</u>	<u>Proposed</u>
	<u>Budget</u>	<u>Budget</u>	<u>Budget</u>	<u>Budget</u>
<b>Beginning Balance</b>	\$ (10,903)	\$ (10,268)	\$ (10,268)	\$ (10,268)
<b>Revenue</b>				
Residential Revenue	180,846	170,380	184,882	191,000
Commercial Revenue	36,345	44,536	55,762	49,000
Interest Income	-	-	-	-
Other Revenues	-	-	-	-
<b>Total Revenue</b>	<u>217,191</u>	<u>214,916</u>	<u>240,644</u>	<u>240,000</u>
<b>Expenditures</b>				
Salaries	91,882	104,783	106,323	113,488
Benefits & Pension	45,334	49,730	51,843	29,806
Professional Services	22,200	20,500	41,477	33,500
Materials & supplies	17,000	17,000	22,538	19,400
Maintenance & Repairs	11,912	11,715	12,100	12,000
Other Expenses	14,750	9,000	13,500	13,500
<b>Total Expenditures</b>	<u>204,778</u>	<u>214,428</u>	<u>247,781</u>	<u>221,694</u>
<b>Transfer Out</b>				
To Admin - Cost Allocation	(76,299)	(82,595)	(82,646)	(84,162)
<b>Transfer In</b>				
From Admin - Tax Appropriation	64,521	82,107	89,783	60,000
<b>Net Annual Activity</b>	<u>635</u>	<u>-</u>	<u>-</u>	<u>(5,856)</u>
<b>Ending Balance</b>	<u>\$ (10,268)</u>	<u>\$ (10,268)</u>	<u>\$ (10,268)</u>	<u>\$ (16,124)</u>

**Rancho Murieta Community Services District  
Solid Waste Fund 400  
FY 2023-24 Proposed Budget**

	<u>FY 2020-21</u> <u>Adopted</u> <u>Budget</u>	<u>FY 2021-22</u> <u>Adopted</u> <u>Budget</u>	<u>FY 2022-23</u> <u>Adopted</u> <u>Budget</u>	<u>FY 2023-24</u> <u>Proposed</u> <u>Budget</u>
<b>Beginning Balance</b>	\$ 87,699	\$ 71,254	\$ 95,893	\$ 95,893
<b>Revenue</b>				
Residential Fees	734,379	984,986	959,893	1,415,227
Interest Income	1,100	1,100	1,200	1,200
<b>Total Revenue</b>	<u>735,479</u>	<u>986,086</u>	<u>961,093</u>	<u>1,416,427</u>
<b>Expenditures</b>				
Contract Sub-hauler	673,947	878,876	978,497	1,259,167
Insurance	-	-	8,422	41,081
County Surcharge	41,761	43,367	45,360	94,176
<b>Total Expenditures</b>	<u>715,708</u>	<u>922,243</u>	<u>1,032,279</u>	<u>1,394,424</u>
<b>Transfer Out</b>				
To Admin - Cost Allocation	(36,216)	(39,204)	(39,789)	(40,077)
<b>Transfer In</b>				
From Admin - Tax Appropriation	-	-	110,975	-
<b>Net Annual Activity</b>	<u>(16,445)</u>	<u>24,639</u>	<u>-</u>	<u>(18,074)</u>
<b>Estimated Ending Balance</b>	<u>\$ 71,254</u>	<u>\$ 95,893</u>	<u>\$ 95,893</u>	<u>\$ 77,819</u>

**Rancho Murieta Community Services District  
Security Fund 500  
FY 2023-24 Proposed Budget**

	<u>FY 2020-21</u>	<u>FY 2021-22</u>	<u>FY 2022-23</u>	<u>FY 2023-24</u>
	<u>Adopted</u>	<u>Adopted</u>	<u>Adopted</u>	<u>Proposed</u>
	<u>Budget</u>	<u>Budget</u>	<u>Budget</u>	<u>Budget</u>
<b>Beginning Balance</b>	<b>(393,951)</b>	<b>(389,111)</b>	<b>\$ (389,111)</b>	<b>\$ (389,111)</b>
<b>Revenue</b>				
Residential Revenue	1,271,694	1,296,743	1,349,131	1,284,000
Commercial Revenue	209,953	226,823	235,986	274,000
Late Fees & Penalties	26,100	26,100	37,100	8,100
Permit Fees	7,800	7,800	7,800	9,000
Interest Income	1,200	1,200	1,200	1,200
Other Revenues	9,600	9,600	14,000	11,660
<b>Total Revenue</b>	<b>1,526,347</b>	<b>1,568,266</b>	<b>1,645,217</b>	<b>1,587,960</b>
<b>Expenditures - Supervision</b>				
Salaries	68,830	100,102	122,790	113,580
Benefits & Pension	95,220	75,848	76,178	56,998
Professional Services	8,377	5,400	5,900	5,900
Materials & Supplies	156	6,000	-	1,000
Maintenance & Repairs	1,441	3,000	-	2,000
Other Expenses	3,293	4,420	1,321	2,150
	<u>177,317</u>	<u>194,770</u>	<u>206,189</u>	<u>181,628</u>
<b>Expenditures - Security Gate</b>				
Salaries	325,042	366,775	383,670	424,227
Benefits & Pension	238,107	201,416	302,343	197,326
Professional Services	45,284	17,088	43,219	50,900
Materials & Supplies	120	120	2,500	5,000
Maintenance & Repairs	7,200	7,200	7,325	7,600
Other Expenses	24,627	15,744	16,120	17,000
	<u>640,380</u>	<u>608,343</u>	<u>755,177</u>	<u>702,053</u>
<b>Expenditures - Security Patrol</b>				
Salaries	292,678	256,907	198,687	190,464
Benefits & Pension	244,523	253,798	212,637	104,179
Professional Services	11,227	34,380	31,851	42,800
Materials & Supplies	120	120	3,500	5,000
Maintenance & Repairs	17,866	17,866	13,666	11,000
Other Expenses	26,222	26,062	16,500	17,000
	<u>592,636</u>	<u>589,133</u>	<u>476,841</u>	<u>370,443</u>
<b>Total Expenditures</b>	<b>1,410,332</b>	<b>1,392,246</b>	<b>1,438,206</b>	<b>1,254,124</b>
<b>Transfer Out</b>				
To Admin - Cost Allocation	(580,627)	(628,536)	(621,602)	(637,227)
<b>Transfer In</b>				
From Admin - Tax Appropriator	469,452	452,516	414,591	50,000
<b>Net Annual Activity</b>	<b>4,840</b>	<b>-</b>	<b>-</b>	<b>(253,391)</b>
<b>Ending Balance</b>	<b>\$ (389,111)</b>	<b>(389,111)</b>	<b>\$ (389,111)</b>	<b>\$ (642,502)</b>



## Rancho Murieta Community Services District

### **Proposed Monthly Billing Rates Effective 07/01/2023 ~ 06/30/2024 Per property type**

<b>Residential Monthly Rates</b>	
Water base	\$ 56.84
Water variable usage per cubic foot	\$ 0.0217
Water Treatment Plant Debt Service	\$ 6.00
Sewer	\$ 68.12
Drainage Tax	\$ 5.64
Security	\$ 32.18

<b>Murieta Village Monthly Rates</b>	
Water base	\$ 56.84
Water variable usage per cubic foot	\$ 0.0217
Water Treatment Plant Debt Service	\$ 6.00
Sewer	\$ 68.12
Drainage Tax	\$ 3.77
Security	\$ 7.76

<b>Villa Monthly Rates</b>	
Water base	\$ 56.84
Water variable usage per cubic foot	\$ 0.0217
Water Treatment Plant Debt Service	\$ 6.00
Sewer	\$ 68.12
Drainage Tax	\$ 3.77
Security	\$ 32.18

<b>Murieta Gardens II Monthly Rates</b>	
Water base	\$ 56.84
Potable Water variable usage per cubic foot	\$ 0.0217
Non-Potable Water variable usage per cubic foot	\$ 0.0217
Sewer	\$ 68.12
Drainage Tax	\$ 3.77
Security	7.76

<b>Solid Waste Rates</b>	
35 Gallon Cart	\$32.76
65 Gallon Cart	\$ 38.96
95 Gallon Cart	\$ 61.33
<b>Additional Garbage Carts</b>	
35 Gallon Cart	\$ 9.46
65 Gallon Cart	\$ 12.61
95 Gallon Cart	\$ 28.98
<b>Additional Recycling Carts (in excess of 1 recycle cart)</b>	
35 Gallon Cart	\$ 7.80
<b>Additional Green Waste Carts (in excess of 2 carts)</b>	
35 Gallon Cart	\$ 7.80
<b>Sacramento County Surcharge</b>	\$ 3.00

<b>Vacant or Unmetered lot Monthly Rates</b>	
Drainage Tax	\$ 5.64
Security Tax	\$ 25.26
Water Availability	\$ 10.00
Sewer Availability	\$ 10.00

Please see rate changes from FY2023-24 on the following pages.

## Rate Change Tables

### WATER

The proposed 2023-24 monthly bill increase for an average consumption residential metered lot is projected to be \$4.11 or 5.0% aggregate when including water usage rates.

	Current Rate 2022-23	Proposed 2023-24
Base Charge (w/o reserve contribution)	\$38.73	\$42.84
Reserve Contribution	\$14.00	\$14.00
<b>Total Base Charge</b>	<b>\$52.73</b>	<b>\$56.84</b>
Debt Service Charge	\$6.00	\$6.00
Usage Charge (per ccf)	\$2.17	\$2.17
<ul style="list-style-type: none"> <li>• Non-residential customers are charged one base charge per month per meter plus the reserve contribution times their Water EDU (equivalent dwelling unit) value plus usage</li> </ul>		

### WASTEWATER

The proposed 2023-24 monthly bill increase for a residential metered lot is projected to be \$7.86 or 13% aggregate.

	Current Rate 2022	Proposed 2023-24
Base Charge (w/o reserve contribution)	\$46.26	\$54.12
Reserve Contribution	\$14.00	\$14.00
<b>Total Base Charge</b>	<b>\$60.26</b>	<b>\$68.12</b>
<ul style="list-style-type: none"> <li>• Non-residential customers are charged the base charge plus the reserve contribution times their Sewer EDU (equivalent dwelling unit) value</li> </ul>		

### SOLID WASTE

The proposed 2023-24 monthly bill increase for a 65-gallon container is projected to be \$11.14 or 40%. This rate increase includes a monthly charge of \$6.53 SB1383 Organics Waste, 4.42% CPI adjustment, \$1.24 charge for one bulk waste pickup and District \$2.00 Franchise Fee. This increase is due to operational cost increases per contract with California Waste Recovery Services and anticipated increases in Sacramento County's landfill surcharges.

	Current Rate 2022-23		Proposed 2023-24
38g container	\$23.42	35g container	\$32.76
64g container	\$27.82	65g container	\$38.96
96g container	\$44.97	95g container	\$61.33
Extra Cart (38g)	\$9.72	Extra cart (35g)	\$9.46
Extra Cart (64g)	\$12.61	Extra Cart (65g)	\$12.61
Extra Cart (96g)	\$27.69	Extra Cart (95g)	\$28.98
Extra Recycle Cart	\$6.91	Extra Recycle Cart	\$7.80
Extra Yard Waste Cart	\$6.91	Extra Yard Waste Cart	\$7.80
Yard Waste Exemption	(\$2.00)	No longer applicable	\$0.00
Sac County Surcharge	\$2.00	Sac County Surcharge	\$3.00

DRAINAGE

The proposed 2023-24 monthly bill increase for an average consumption residential metered lot is projected to be \$0.11 or 2.0%.

Developed Property	Current 2022-23	Proposed 2023-24	Max Rate 2023-24
<b>Residential (per lot)</b>			
Metered	\$5.53	\$5.64	\$5.64
Unmetered	\$5.53	\$5.64	\$5.64
The Villas	\$3.70	\$3.77	\$3.77
Murieta Village	\$3.70	\$3.77	\$3.77
Murieta Gardens	\$3.70	\$3.77	\$3.77
<b>Non-Residential (per acre)</b>			
1 Retail	\$27.69	\$28.24	\$28.24
2 Industrial/Whse	\$29.44	\$30.03	\$30.03
3 Light Industrial	\$22.51	\$22.96	\$22.96
4 Office	\$25.97	\$26.49	\$26.49
5 Landscape (golf course/park sites)	\$5.19	\$5.29	\$5.29
6 Murieta Equestrian Center	\$2.01	\$2.05	\$2.05
7 RMCC (club house and parking)	0.00	0.00	0.00
8 Airport	\$2.32	\$2.37	\$2.37
9 Geyer Property	\$17.32	\$17.66	\$17.66
10 Hotel/Ext Stay	\$27.70	\$28.25	\$28.25
<b>Undeveloped Property</b>			
Residential & Non-Residential	\$3.27	\$3.34	\$3.34

SECURITY

The proposed 2023-24 monthly bill increase for a residential metered lot inside the RMA gates is projected to be \$0.63 or 2.0%.

Developed Property	Current 2022-23	Proposed 2023-24	Max Rate 2023-24
<b>Residential (per lot)</b>			
Inside Gates			
Metered	\$31.55	\$32.18	\$32.18
Unmetered	\$24.76	\$25.26	\$25.26
Outside Gates	\$7.61	\$7.76	\$7.76
<b>Non-Residential (per Building square foot)</b>			
1 Highway Retail	\$ .2845	\$ .2901	\$ .2901
2 Other Retail/Comm	\$ .0306	\$ .0312	\$ .0312
3 Industrial/Whse/Lt Industrial	\$ .0669	\$ .0682	\$ .0682
4 Office	\$ .0161	\$ .0164	\$ .0164
5 Institutional	\$ .0161	\$ .0164	\$ .0164
6 Public Utility	\$ .0510	\$ .0520	\$ .0520
7 Equestrian Center	\$ .0048	\$ .0049	\$ .0049
8 RMCC	\$ .0801	\$ .0817	\$ .0817
9 Airport	\$ .0204	\$ .0208	\$ .0208
10 Hotel/Ext Stay	\$ .0306	\$ .0312	\$ .0312
<b>Undeveloped Property (per acre)</b>			
Inside Gates	\$26.6888	\$27.2225	\$27.2225
Outside Gates	\$3.9771	\$4.0566	\$4.0566



# Rancho Murieta Community Services District

FY 2023-24

Proposed Capital  
Improvement Plan





**RANCHO MURIETA COMMUNITY SERVICES DISTRICT**  
**FY 2023-24 Proposed Budget**  
**Capital Improvement Projects**

<b>Project Number</b>	<b>Project Name</b>	<b>Project Budget</b>
<b>Water</b>		
24-200-01	Water portion of CIP/5-year rate study	225,000
24-200-02	Integrated Water Master Plan	200,000
24-200-03	Water GIS Updates	25,000
24-200-04	Water Condition Assessment	30,000
24-200-06	Rio Oso Improvement Study	61,000
24-200-07	WTP Chlorine to NaOCl replacement	700,000
24-200-08	Granlees Safety Rehabilitation	822,000
		<b>2,063,000</b>
<b>Wastewater</b>		
24-250-01	Wastewater portion of CIP/5-year rate study	175,000
24-250-02	Wastewater GIS Updates	25,000
24-250-03	Wastewater Condition Assessment	30,000
24-250-05	Complete Lift Station Generator Projects	450,000
24-250-06	Complete Lift Station Rehabilitation Projects	300,000
24-250-07	Main lift North Pump Replacement	65,000
24-250-08	Main lift North Roof Repair	15,000
24-250-09	Complete WWTF Chlorine to NaOCl & Contact Tank Rehabilitat	1,400,000
		<b>2,460,000</b>
<b>Security</b>		
24-500-01	Security Compound Replacment	250,000
		<b>4,773,000</b>





# Rancho Murieta Community Services District

## Water Projects



**FUND:** Water

**PROJECT TITLE:** Capital Improvement Planning & Five-Year Rate Study

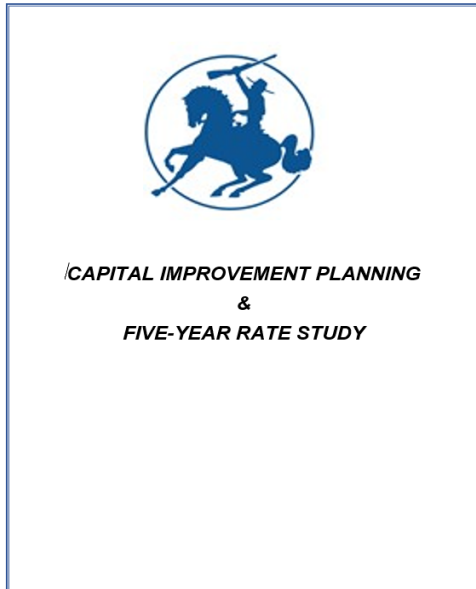

**CIP #:** 24-200-01

**PROJECT BUDGET:** \$225,000

**PROJECT DESCRIPTION:** Create a Capital Improvement Plan and five-year Rate Study

**JUSTIFICATION:**

This project will create and organize a database of existing and future infrastructure and assign useful life and replacement value to model the capital needs of the District over a 20-year capital planning horizon. This project will also take the capital assessment information and other financial information and create a 5-year cost of service study that will support the long term operating and capital needs of the District.



**FUND:** Water

**PROJECT TITLE:** Integrated Water Master Plan Completion

**INTEGRATED WATER MASTER PLAN**

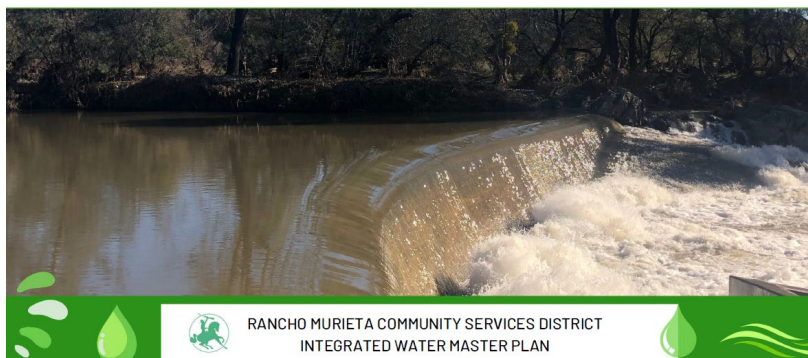

**CIP #:** 24-200-02

**PROJECT BUDGET:** \$200,000

**PROJECT DESCRIPTION:** Complete the Integrated Water Master Plan

**JUSTIFICATION:**

Complete the work started on the Integrated Water Master Plan in fiscal year 22-23 to evaluate the District water & recycled water supply, including expansion of the story map, hydraulic modeling, water use modeling, evaluation, and holding meetings for public engagement.

**RANCHO MURIETA COMMUNITY SERVICES DISTRICT  
CAPITAL IMPROVEMENT PLAN  
FY 2023-24**



**FUND:** Water

**PROJECT TITLE:** GIS System Upgrade

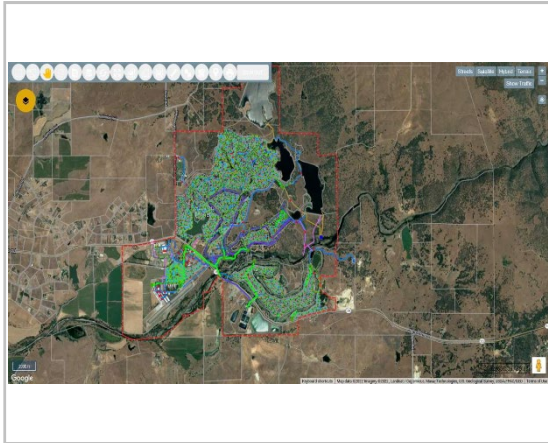

**CIP#:** 24-200-03

**PROJECT BUDGET:** \$25,000

**PROJECT DESCRIPTION:** Upgrades to existing Geographical Information System (GIS)

**JUSTIFICATION:**

Continue the efforts to enhance the existing District GIS updates, including asset inventory database expansion, and condition assessment data expansion. Other possible data inventory may include security monitoring, water use, and account information access.

**FUND:** Water  
**PROJECT TITLE:** Condition Assessment

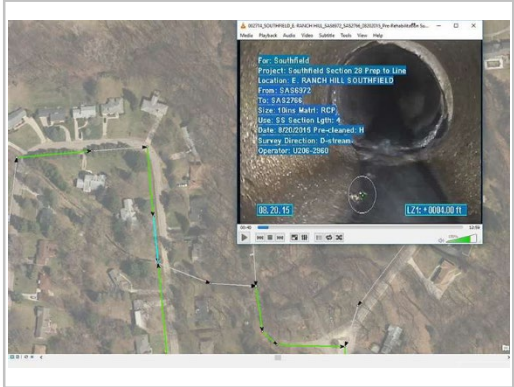

**CIP #:** 24-200-04  
**PROJECT BUDGET:** \$30,000  
**PROJECT DESCRIPTION:** Condition Assessment

**JUSTIFICATION:**

Continue the annual condition assessment program which includes assessing water and Wastewater infrastructure via vibration analysis (water) and CCTV rating (wastewater). Condition assessment information will be uploaded to GIS.

**FUND:** Water

**PROJECT TITLE:** Rio Oso Configuration Study



**CIP#** 24-200-06

**PROJECT BUDGET:** \$61,000

**PROJECT DESCRIPTION:** Complete Rio Oso Configuration Study

**JUSTIFICATION:**

Complete a study to determine the best configuration for future improvement of the pressure zone pump station, including the evaluation of pressure attenuation, diurnal pumping infrastructure, and long-term building needs to house equipment.

**FUND:** Water

**PROJECT TITLE:** Complete Water Treatment Plant Chlorine Gas to Sodium Hypochlorite Disinfection Project



**CIP#** 24-200-07

**PROJECT BUDGET:** \$700,000

**PROJECT DESCRIPTION:** Complete Water Treatment Plant Chlorine Gas to Sodium Hypochlorite Disinfection

**JUSTIFICATION:**

Continue the project to replace chlorine gas with liquid sodium hypochlorite for disinfection at the water treatment facility. The next phase of this project will be the construction of improvements and start-up of the new disinfection facility.

**FUND:** Water

**PROJECT TITLE:** Complete Granlees Intake Safety Rehabilitation Project



**CIP#:** 24-200-08

**PROJECT BUDGET:** \$822,000

**PROJECT DESCRIPTION:** Complete Granlees Intake Safety Rehabilitation Project

**JUSTIFICATION:**

Continue the project to replace the roof access of the Granlees water intake structure and to replace several isolation gates, railings and related appurtenances. The next phase of the project is completion of the design and the construction of the repair and replacement infrastructure.





# Rancho Murieta Community Services District

## Wastewater Projects



**FUND:** Wastewater

**PROJECT TITLE:** Capital Improvement Planning & Five-Year Rate Study

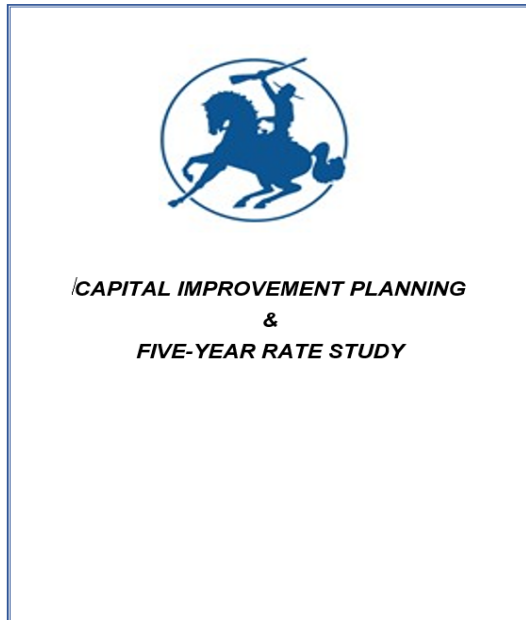

**CIP #:** 24-250-01

**PROJECT BUDGET:** \$175,000

**PROJECT DESCRIPTION:** Create a Capital Improvement Plan and five-year Rate Study

**JUSTIFICATION:**

This project will create and organize a database of existing and future infrastructure and assign useful life and replacement value to model the capital needs of the District over a 20-year capital planning horizon. This project will also take the capital assessment information and other financial information and create a 5-year cost of service study that will support the long term operating and capital needs of the District.



**FUND:** Wastewater

**PROJECT TITLE:** GIS System Upgrades

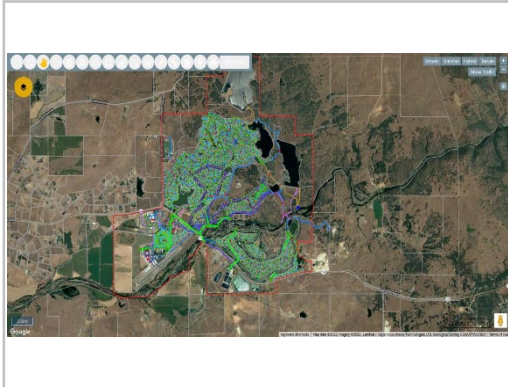

**CIP #:** 24-250-02

**PROJECT BUDGET:** \$25,000

**PROJECT DESCRIPTION:** Upgrades to existing Geographical Information System (GIS)

**JUSTIFICATION:**

Continue the efforts to enhance the existing District GIS updates, including asset inventory database expansion, and condition assessment data expansion. Other possible data inventory may include security monitoring, water use, and account information access.

**RANCHO MURIETA COMMUNITY SERVICES DISTRICT  
CAPITAL IMPROVEMENT PLAN  
FY 2023-24**



**FUND:** Wastewater

**PROJECT TITLE:** Condition Assessment

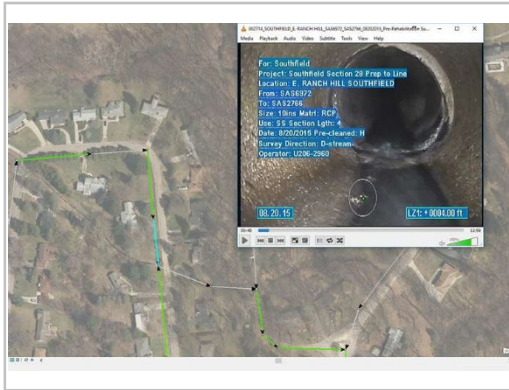

**CIP #:** 24-250-03

**PROJECT BUDGET:** \$30,000

**PROJECT DESCRIPTION:** Condition Assessment

**JUSTIFICATION:**

Continue the annual condition assessment program which includes assessing water and Wastewater infrastructure via vibration analysis (water) and CCTV rating (wastewater). Condition assessment information will be uploaded to GIS.

**FUND:** Wastewater

**PROJECT TITLE:** Lift Station Generator Projects



**CIP #:** 24-250-05

**PROJECT BUDGET:** \$450,000

**PRODUCT DESCRIPTION:** Complete Repairs to FAA and Cantova Lift Stations

**JUSTIFICATION:**

Complete electrical design, procure and install generators and switch gears, and construct related infrastructure improvements to support the maintenance access and installation of the generator equipment at the FAA and Cantova lift stations.

**FUND:** Wastewater

**PROJECT TITLE:** Complete Lift Station Rehabilitation



**CIP #:** 24-250-06

**PROJECT BUDGET:** \$300,000

**PRODUCT DESCRIPTION:** Complete Repairs to Starter Shack and Altamont Lift Stations

**JUSTIFICATION:**

Continue the project to rehabilitate the Starter Shack, Lift 3B, and the Altamont lift station pumping systems. The construction phase of this project will extend into this next fiscal year.

**FUND:** Wastewater

**PROJECT TITLE:** Main Lift North Pump Replacement



**CIP #:** 24-250-07

**PROJECT BUDGET:** \$65,000

**PRODUCT DESCRIPTION:** Replace Main Lift North Pump

**JUSTIFICATION:**  
Procure a replacement redundant pump for the previously stored redundant pump that was put into service in the Fall of 2022.

**FUND:** Wastewater

**PROJECT TITLE:** Main Lift North Roof Repair



**CIP #:** 24-250-08

**PROJECT BUDGET:** \$15,000

**PRODUCT DESCRIPTION:** Repair Main Lift North Roof

**JUSTIFICATION:**

Repair roof damage to prevent continued leakage to the Main Lift North station control room.



**FUND:** Wastewater

**PROJECT TITLE:** Chlorine Gas to Sodium Hypochlorite and Contact Tank Rehabilitation Project



**CIP #:** 24-250-09

**PROJECT BUDGET:** \$1,400,000

**PRODUCT DESCRIPTION:** Rehabilitate Tertiary Disinfection System

**JUSTIFICATION:**

Continue final design efforts, construction, and start-up services related to replacing the current chlorine gas system at the tertiary treatment facility with a liquid sodium hypochlorite feed and storage system and constructing a replacement chlorine contact tank and associated controls and appurtenances.



# Rancho Murieta Community Services District

## Security Projects

**FUND:** Security

**PROJECT TITLE:** Security Compound Replacement



**CIP #:** 24-500-01

**PROJECT BUDGET:** \$250,000

**JUSTIFICATION:**

Continue efforts to replace the existing modular trailer that houses the Security department with a new or refurbished modular trailer. This project includes support of continued adherence to ADA requirements and restoration of surrounding landscaping and parking lot infrastructure associated with the modular building.



## Rancho Murieta Community Services District

15160 Jackson Road • P.O. Box 1050 Rancho Murieta, CA 95683 • 916-354-3700 • Fax 916-354-2082

Visit our website [www.rmcsd.com](http://www.rmcsd.com)

June 12, 2023

Dear Rancho Murieta community Residents;

The Directors of the Rancho Murieta Community Service District Board (District) would like to update you regarding the Sacramento County Civil Grand Jury Report ([2022-3023 Grand Jury Report Rancho Murieta Community District Services](#)).

As required by the Grand Jury, the District's legal counsel has submitted the District's official response to the Grand Jury's presiding judge, the Honorable Michael Bowman.

The Board, however, wants to provide a more detailed response to the community so the community members are more fully informed of the findings, the district's decisions, and the district's actions over the years leading up to the grand jury investigation. To that end, I'm sharing a list of the **Grand Jury's Findings and Recommendations** in this document, along with brief histories on each finding and an update on the efforts made to date by the District to remedy each finding.

I would like to thank the members of the Sacramento County Civil Grand Jury for their time, effort, understanding, and willingness to listen to and ask pertinent questions, in order to gain knowledge of the Rancho Murieta community and the specific responsibilities and mission of the District. Their commitment to a thorough fact-finding process to obtain an accurate understanding of District operations was clear.

Some District staff and board members participated directly in the interview process with the Civil Grand Jury as part of the overall evaluation and I'm also grateful for their contributions to the process.

The District directors and staff greatly appreciate the integrity of the Grand Jury report, which correctly identifies many issues facing the District which the current directors have been working on over the last several years. Perhaps the most important of these issues is the significant shortfall in reserve funding needed to replace plant equipment before it breaks or becomes obsolete. Functional plant equipment is the most critical component of our service delivery model. These findings will serve as a "road map" for the District for the next several years, guiding our commitment to stronger accountability and the essential financial planning for equipment replacement and upgrades.

We sincerely hope to restore the community's trust and understanding in the District by demonstrating good faith efforts currently underway. We will communicate extensively on our progress through established public forums, the District website, board and committee meetings, town hall meetings, updates in the local print media, and, when appropriate, individual meetings with members of the public.

We appreciate your support as we address these issues.

Sincerely

Timothy E. Maybee  
President, Rancho Murieta Community Services District Board

*Serving the Community for over 30 years*

Board of Directors: Tim Maybee, President • Martin Pohll, Vice-President • Randy Jenco • Linda Butler • Martin Pohll • Stephen Booth  
General Manager • Mimi Morris

## **RANCHO MURIETA COMMUNITY DISTRICT REPORT TO THE COMMUNITY REGARDING 2022-2023 GRAND JURY REPORT**

***FINDING # 1: THE DISTRICT BOARD HAS LOST THE TRUST OF THE COMMUNITY TO MAKE PRUDENT FINANCIAL DECISIONS.***

***GRAND JURY RECOMMENDATION: The District board should upgrade the District's billing and accounting system with the new Enterprise Resource Planning (ERP) accounting system by January 1, 2024.***

### ***DISTRICT RESPONSE, IN BRIEF:***

The first phase of implementation of the new ERP started the week of May 1<sup>st</sup>, 2023. The implementation will continue in stages as District employees are trained and fiscal information is available to populate the specific programs within the system.

### ***DISTRICT RESPONSE, DETAILED:***

The Board regrets any loss of trust that may have occurred and is committed to working to restore full trust in the organization. Significant issues have faced the organization including an antiquated accounting system, high employee turnover, and insufficient resources to replace outdated equipment. The current Board knew the challenges they faced when they assumed their role and began to work to correct the District's financial well-being as soon as they took office.

As long ago as the 2018 District Board election, candidates identified the need for funding reserve accounts and indicated a better understanding of how security services were provided and funded was critical. Upon election, Board members understood more fully that reserves were not being funded adequately on a regular basis and property taxes were being used to fund additional security services outside of Measure J.

The new Board members also realized that little work had previously been done to correct these critical funding issues. This knowledge prompted the Board to set as its priority closing the reserve gap.

The current Directors understood their responsibility to make difficult fiscal decisions, and, at the first opportunity, took action to attempt to correct the issue, committing for the first time ever a dedicated amount of funding to the reserve funding accounts. This happened as part of the FY21-22 budget in which the Board added additional charges to monthly residential bills totaling approximately \$210,000 annually for water reserve funding, and \$243,000 for wastewater reserve funding.

Community distrust was understandable due to the accounting system hurdles which led to such red flags as missed deadlines for required annual audits. Directors initiated work to procure and implement a new ERP in March of 2020.

**FINDING # 2: THE CURRENT ACCOUNTING SYSTEM IS INADEQUATE TO MEET THE LEGAL REQUIREMENTS RELATED TO FINANCIAL REPORTING TO THE PUBLIC WHICH HAS RESULTED IN TWO LEGALLY REQUIRED FINANCIAL AUDITS BEING OVERDUE.**

**AND**

**FINDING # 3: THE LATE AUDITS, COMBINED WITH THE UNRELIABLE EXISTING ACCOUNTING SYSTEM, HAVE CREATED AN ENVIRONMENT THAT EXPOSES THE DISTRICT TO A HIGH RISK OF FRAUD**

**AND**

**FINDING # 4: THE DISTRICT BOARD CANNOT EXPECT TO RECOVER PUBLIC TRUST SUFFICIENT TO PROPOSE ANY TAX/FEE INCREASES UNTIL IT REPLACES ITS ANTIQUATED BILLING AND ACCOUNTING SYSTEM TO PRODUCE RELIABLE BILLINGS AND FINANCIAL RECORDS.**

**GRAND JURY RECOMMENDATIONS RELATED TO THESE FINDINGS:**

**#R2: The District board should ensure that the audit for FY20-21 is completed no later than April 1, 2023, and the FY21-22 audit by September 1, 2023.**

**#R3: The district Board should task its ERP consultant to implement a program to fully train District accounting staff on this new accounting system and prepare new accounting manuals acceptable to the General Manager or designee by January 1, 2024.**

**#R4: The District Board should retain a controller to ensure proper accounting procedures are followed and the integrity of the accounting data is maintained by January 1, 2024.**

**#R5: The District needs to ensure invoices are tracked within the accounting system and that the accounts payable listing be generated on a monthly basis by September 1, 2023.**

**DISTRICT RESPONSE, IN BRIEF:**

**R2.** The District agrees that annual audits are critical and need to be completed as soon as possible. FY20-21 financial information was provided to the auditor in April and May of 2023. Financial information for FY21-22 will be provided to the auditor by October 1, 2023. Financial information for the FY22-23 will be submitted to Richardson and Associates (Richardson) by December 1, 2023. Typically, an audit is performed 6-9

months after year end, making a “normal” FY21-22 audit completion around March of 2023. Because FY20-21 was not audited in a timely manner, it has impacted the FY21-22 timeline, but the District will get back on track by early 2024.

**R3.** The District agrees that the new accounting system must be a priority and has hired a new General Manager who will ensure that the ERP implementation is moving forward. The process requires analyses of existing processes and procedures for each module and corresponding configuration of the system, data transfers to the new system and staff training. Full implementation is projected to be completed by December 2024.

**R4.** The District agrees that staff with sufficient financial management expertise must be on board and contracted the services of the national firm Municipal Resource Group (MRG) to recruit key staff positions, including a Controller/Accounting Manager.

**R5.** The District agrees that a system to track invoice payments is critical. An outside accounting firm evaluated the District’s Invoice Processing Procedures and staff initiated new invoice processing procedures that will be in place until the new ERP system is implemented. The new procedures ensure accountability for all payments and corresponding separation of duties for improved internal control.

***DISTRICT RESPONSE, DETAILED:***

The District is required to have two annual audits: one for the general district operations and one for community facilities. These are referenced as the Community Services District (CSD) audit and the Community Facilities District No. 2014-1 (CFD), respectively.

**FY20-21 CSD:** Financial information was submitted to Richardson in late May, 2023.

**FY20-21 CFD 2014-1:** Financial information was submitted to the external, contracted auditing firm, Richardson in April of 2023.

**FY21-22** Financial information for both audit areas will be submitted to Richardson by October 1, 2023.

**FY22-23** financial information for both audit areas will be submitted to Richardson by December 1, 2023.

The Board agrees annual audits are and are an important part of financial management. We regret that the audits for FY 20-21 and FY21-22 have not yet been finalized. Typically, an audit is performed 6-9 months after year end, making a “normal” FY21-22 audit completion around March of 2023, roughly the same time the Grand Jury Report was released. The delayed closure and audit of FY20-21 impacted the FY21-22 timeline, making the audit late by 3-6 months. The District is working to get all audits back on track by early 2024.

In April of 2019, the Board hired the PUN Group to streamline and simplify the accounting and reporting processes. In April of 2020, the FY18-19 CSD audit revealed significant deficiencies and material weaknesses due to the District’s antiquated accounting system and corresponding procedures. In early 2021 the Board established the goal of replacing the accounting system.

The Board is committed to finalizing the two overdue audits (FY20-21 and FY21-22) as soon as possible. The limitations of the current accounting system are the major hurdle to finalizing the prior year audits. In 2022, the District again engaged the services of the Pun Group to validate and close out prior years' books so the audits can be performed and finalized. The FY20-21 audit is expected to be finalized by August 1, 2023, and the FY21-22 audit is expected to be finalized by April of 2024.

An effort to replace the old system with a more functional, more reliable, and more automated system has been a goal since 2021 and the solicitation for that system was initiated in Spring of 2021. A vendor was selected in Fall of 2021 and in January of 2022, Tyler Technologies began the process of developing a comprehensive Enterprise Resource Program (ERP). The ERP includes several key modules, which must be configured to match District policies and procedures. The first module (on Utility Billing) was implemented in April of 2023. The remaining modules are targeted for completion by December of 2024. The implementation will include comprehensive training for district accounting staff and all relevant system documentation including accounting manuals to ensure successful continuity of usage. The District has hired a new General Manager who is ensuring that the ERP implementation is moving forward. The implementation process requires analyses of existing processes and procedures for each module and corresponding configuration of the system, data transfers to the new system and staff training. Full implementation is projected to be completed by December 2024.

The District agrees that the need to have strong internal controls and capable staff is critical for effective, risk-free operation of the organization. The District has contracted the services of the national firm Municipal Resource Group (MRG) to recruit key staff positions, including a Controller/Accounting Manager. The goal is to hire an individual with strong financial management skills to ensure proper accounting procedures are established and followed to guarantee the integrity of the accounting data.

The District's Invoice Processing Procedures have been evaluated by the Pun Group. New processes have been put in place and mapped to the new ERP system to ensure accountability for all payments and corresponding separation of duties for improved internal control. An Accounts Payable report will be generated each month for the General Manager's review by September 1, 2023.



**FINDING # 5: THE DISTRICT HAS AT TIMES TAKEN ACTIONS AGAINST STAFF THAT HAS INTERFERED WITH THE OPERATION OF THE DISTRICT.**

**AND**

**FINDING # 6: HIGH EMPLOYEE TURNOVER INDICATES POOR EMPLOYEE RETENTION THAT HAS INTERFERED WITH THE OPERATION OF THE DISTRICT.**

**AND**

**FINDING # 7: THE LACK OF AN EFFECTIVE SUCCESSION STRATEGY HAS IMPAIRED THE ABILITY OF THE DISTRICT TO MAINTAIN ADEQUATE COMPETENT STAFF WHICH HAS RESULTED IN THE LOSS OF CRITICAL ACCOUNTING SYSTEM KNOWLEDGE AMONG THE DISTRICT STAFF.**

***GRAND JURY RECOMMENDATIONS RELATED TO THESE FINDINGS:***

***#R6. The District should create an ongoing training program for the Board and staff regarding the Brown Act compliance, accounting procedures, and work-place practices and behaviors including prevention of harassment in the work environment. This should be fully implemented in 2024.***

***#R7. The District should adopt a policy to ensure that proposed personnel adverse actions are reviewed by someone not in the chain of command to ensure that proper procedures are followed. In the case of proposed adverse actions by executive staff this could be accomplished through the use of an outside expert in personnel matters or legal counsel.***

***#R8. The District Board should require administration to report quarterly on staff development and staff identified concerns beginning October 1, 2023.***

***DISTRICT RESPONSE, IN BRIEF:***

**R6.** The District agrees that an ongoing staff and Board training program regarding Brown Act compliance, accounting procedures, and work place practices and behaviors including prevention of harassment in the work environment should be fully implemented by 2024.

**R7.** The District also agrees that the organization needs a policy to ensure that proposed personnel adverse actions are reviewed by someone not in the chain of command to ensure that proper procedures are followed.

**R8.** The District agrees that quarterly reporting on staff development and identified concerns should occur starting in the next few months.

### ***DISTRICT RESPONSE, DETAILED:***

The District agrees that good human resources management is important for organizational effectiveness. However, Finding #5 is vague, but can be interpreted to mean that the District has taken improper or ill-advised employment actions in the past that have affected District operations. The Board disagrees with this finding. The Board only has employment authority over the District General Manager. The Board has no employment authority over subordinate District employees as all such authority is delegated to the District General Manager. As to any employment actions taken against subordinate staff by past District General Managers, the Board may not comment on confidential personnel matters, which includes all such employment actions.

The District agrees that trainings are important and will initiate annual Board and staff trainings to address gaps identified in the Grand Jury report.

The Board agrees that high employee turnover has had one of the most significant negative impacts on the District's financial management. The District Board and General Manager will perform employee exit interviews for all departing employees going forward. Key personnel have left the District for a variety of reasons over the last several years, including parental obligations, more competitive pay, shorter commutes, and a more positive work environment.

Critical accounting staffing positions remain unfilled within the District due to difficulties finding qualified candidates. The main reasons given to the District for individuals declining employment offers are a noncompetitive salary, a long daily commute and heavy workload. The District will continue to recruit and train current employees to ensure all staff positions have the right person for the right jobs. The District has and will continue to engage national recruitment firms to assist in the hiring processes.

The necessity of having skilled and knowledgeable accounting staff has been very clear to the Board for over a year. To address these issues, the District has been contracting with national consulting firms, Municipal Resource Group (MRG) and Robert Half and Associates, to assist with both the short term and long-term recruitment of key accounting personnel. Most recently, MRG was instrumental in recruiting the new General Manager.

With the appointment of the new General manager, staff will look to her for leadership and knowledge in governmental accounting which will place the District in a position to establish the needed succession planning, training, recruitment and improve employee morale.

***FINDING #8: THE LACK OF AN UPDATED CAPITAL RESERVE POLICY HAS CONTRIBUTED TO POOR MANAGEMENT AND INADEQUATE CAPITAL RESERVE.***

***GRAND JURY RECOMMENDATIONS RELATED TO THIS FINDING:***

***#R11. The District Board should revise its current capital reserve fund policy to identify specific funding goals for each capital asset category with supporting fees sufficient to meet the long-term infrastructure needs of the District.***

**DISTRICT RESPONSE, IN BRIEF.**

The Board agrees that service fees sufficient to meet the long-term infrastructure needs of the District are critical and will start this effort with the budget for FY23-24.

**DISTRICT RESPONSE, DETAILED.**

The Board initiated a reserve study in March 2022. This report identified the critical risk resulting from the District's lack of adequate reserve funding. The critically low reserve funding levels grew over many fiscal years. The Board took action to increase reserve fund levels as soon as it could in FY21-22.

Earlier this year (FY22-23), the Board began the process of updating the District policy relating to reserve funding, as recommended in the reserve study report. However, progress on a revision was limited due to lack of community support for rate increases.

As the District enters FY23-24 the 2012 District Reserve Policy will be updated to reflect the need for reserves that fully cover anticipated future capital outlay needs.

The Board has given direction to staff to start the process for contracting with consulting firms to address both a five-year Rate Study and a cost allocation study for the District. Both of these studies will be finalized in FY23-24.

***FINDING #9: THE USE OF COUNTY PROPERTY TAX FUNDS TO SUBSIDIZE ITS GROWING SECURITY COSTS WITHOUT RAISING THE SECURITY FEES HAS JEOPARDIZED THE FINANCIAL STABILITY OF THE DISTRICT.***

***GRAND JURY RECOMMENDATIONS RELATED TO THIS FINDING:***

***#R9. The District should reduce its security services funding to a level that is supported by fees paid by residents specific to fund security services.***

***#R10: Effectively immediately, County tax funds currently allocated to security services, should be redirected to the Capital Reserves.***

***DISTRICT RESPONSE, IN BRIEF.***

The Board disagrees partially with this finding. The Board agrees that, in recent years, security costs have exceeded available existing security special tax revenues. However, the Board disagrees that this issue has jeopardized the financial stability of the District. As discussed in response to Finding 1 above, the Board is reviewing the continued viability of current security service levels due to the insufficiency of existing special tax stream, competing priorities for limited property tax revenue, and District voters not approving new special tax revenues to support security.

**R9.** The District will work to reduce its security services funding levels to match fees paid by residents starting in FY23-24. The lower level of services will be directly aligned to Measure J tax revenues by FY24-25.

**R10.** The full use of county tax funds for capital reserves will begin to take effect in FY23-24. With the goal of meeting the Sacramento County Civil Grand Jury's recommendation of \$10 million additional dollars assigned to reserve funding levels.

***DISTRICT RESPONSE, DETAILED.***

In 1985 residents of Rancho Murieta voted in the Sacramento County election, in favor of ballot [Measure A Text](#). This established the authority for RMCS D security to enforce any Homeowners Association (HOA) covenants, conditions and restrictions (CC&R). This enforcement authority was then adopted in RMCS D Board [Resolution 85-9](#).

In [1998 Measure J](#) was voted and approved ([Measure J election results](#)), during the Sacramento County election. This measure authorized a security revenue tax rate with a maximum of 2% increase per fiscal year. In the 20 years since the passage of Measure J, costs and expectations for security have both increased. The annual 2% increase has not kept pace with the increased costs. This gap led to the use of the property tax allocation to cover the expected security services.

In 2019, the Board and District legal counsel confirmed that the usage of property tax to fund security, while a legally authorized use of these general funds, was not in the best interest of the long term financial health of the District. The Board then began the process of demonstrating the insufficiency of security resources provided by Measure J and also requested an evaluation and update on the District's cost allocation process. A national firm, ClearSource, completed an updated full accounting of all associated costs for security, water and wastewater operations, drainage, administration and trash collection costs.

As it became clear that usage of property tax to cover the insufficiency of Measure J tax revenue for expected security services could no longer continue because of the impact to reserve funding, the Board explored options for more sufficient tax revenue funding to cover the expected security services. The Board gave direction to staff to place a ballot measure on the 2022 Sacramento County election schedule. This Measure, [Measure R](#), would have authorized a special security tax of \$316 per per per parcel with annual increases of up to 5%.

Recognition of the need to revise the way security services were being funded, to address the appropriate legal context of Measure J, began at the [March 26, 2020 Board meeting](#). The Board determined that it was inappropriate to use property tax to fund security services and they would no longer be used.

In February of 2021, the District entered into [contract services to True North Research](#) to research how much residents would be willing to pay for Security. The results from the True North Study came in and the Board asked staff to place Measure R on the ballot on page 6 of [April 2022 Board Packet](#). Staff updated the Board at the [May 2021 Board meeting](#) (p. 142 of Packet)

The District hired Clifford Moss on May 5, 2022 to educate the community on Measure R and the need for alternative tax revenue funding since Measure J does not fully cover the costs of expected security services.

The District held a [Townhall meeting June 22, 2021](#) at RMCC to share the results of the research with the community, including specifically the additional funds that would be required to fund security at its current level without the use of property tax allocations.

There had long been a gap in the funding provided through Measure J and the funding needed for expected security service levels provided by the District. The Board tried to address that gap through Measure R, but Measure R failed in the general election. The final results of the vote for Measure R can be seen on page 47 of the [December 2022 Board Packet](#).

The District is now focused on how to determine what level of security services can be provided within available security resources provided by Measure J and is working with the Rancho Murieta Association (RMA) to map out security service levels.

**FINDING #10: THE CAPITAL RESERVES ARE UNDERFUNDED BY OVER \$10 MILLION, JEOPARDIZING THE FINANCIAL STABILITY OF THE DISTRICT.**

**GRAND JURY RECOMMENDATIONS RELATED TO THIS FINDING:**

**#R11. The District Board should revise its current capital reserve fund policy to identify specific funding goals for each capital asset category with supporting fees sufficient to meet the long-term infrastructure needs of the District.**

**DISTRICT RESPONSE, IN BRIEF.**

The Board disagrees partially with this finding. The Board agrees that capital reserves are currently underfunded. However, the Board disagrees that this issue has jeopardized the financial stability of the District. As discussed in response to Finding 1 above, the Board believes updating the District's capital reserves policy and adequately funding District reserves are priority issues, but it is not possible to address these issues until the District's larger legacy accounting issues have been addressed.

**DISTRICT RESPONSE, DETAILED.**

Again in the 2018 District election cycle, then RMCS D Board candidates stated that reserve funding was of high concerns and a top priority. Every fiscal year's budgets since then, the reserves were the highest priorities of the Board. The need for fiscal responsibility has been the signal most significant concerns of this current Board. As identified in the FY22-23 budget the rate of increase for the sole purpose of aligning the immediate fiscal needs of the District.

This was identified by the consulting firm [Associated Reserves \(3/28/2022\) report](#). This firm determined that the District's reserves were only funded at 25.9%. When in reality the District needed to be at a minimum of 70%, and ideally should be funded at 100% reserve funding. This places the District high risk of completely inadequate levels of reserve funding. The recommendation of the report was to immediately start increasing reserve funding at a minimum \$1.2 million dollars per fiscal year.

The number one [goal](#) was to budget for the reserves based on Reserve Study Outcome.

The March 28, 2022 Board Packet discusses Association Reserve results along with the Board's updated Draft Reserve Policy, which was not implemented. At the March 30, 2022 the Board Backed discusses the FY22-23 budgetary process. Review page 16 of this packet details the Board's request for 60% of the reserves to be funded in 5 years, and their approval of \$11 dollar for water reserve increase and \$10 wastewater reserve increase.

There was a successful protest to the Prop 218 process of the District's fiscal budgetary processes. This led to no increase in any additional revenue increase for the entire fiscal year. This negative impact, due to inflationary costs alone, places the District at an even more increased of risk for reserve funding levels.

Here is a link to the final report of addresses for [Prop 218 protest letters](#).

The RMCS D Board is still committed to a full and compete funding level of reserve funding. See FY23-24 draft Budget.

***FINDING #11: THE DISTRICT HAS INAPPROPRIATELY SUBSIDIZED THE COST OF RECLAIMED WATER TO RMCC.***

***GRAND JURY RECOMMENDATIONS RELATED TO THIS FINDING:***

***#R12: The District Board should revise its agreement with the RMCC and begin charging for the use of reclaimed water on the RMCC golf courses at rates typical in the Sacramento area by January 1, 2024.***

***DISTRICT RESPONSE, IN BRIEF.***

The Board disagrees wholly with this finding. The District's current reclaimed water operations are designed to comply with regulatory and legal requirements. First, the District's wastewater permit has long prohibited the District from discharging treated effluent from the District's wastewater treatment plant to waterways. The only approved disposal method for District treated effluent is irrigation within the authorized areas described in the permit. To remain in compliance with its wastewater permit, the District must have a reliable irrigation user for its treated effluent. The District addresses these constraints by disposing of its treated effluent by providing it to the country club for irrigation uses. Second, the District and country club are parties to a long-term agreement that requires the District to provide its treated effluent to the country club. The agreement does not contain terms authorizing the Board to terminate the agreement, charge for the treated effluent, or sell the effluent to other parties.

***DISTRICT RESPONSE, DETAILED.***

When this community was established in the early 1970's the design was truly ahead of its time. The RMCCSD is one of only community service districts in the State that delivers these levels of services; water storage & treatment and delivery, wastewater recycle treatment, sewer, drainage, trash collection and security service. Most community service districts do not provide this many services, only one or two services are the norm. To this end the usage of recycled water within the District was amazingly designed and effective in its usage of this recycle water.

Water from the Cosumnes river is pumped to the water storage reservoirs and then pumped to the water treatment plants for distribution. Then water is delivered to houses and commercial properties, with the return of wastewater to District holding ponds and treatment plants. The amount of total water handled by the District annually is close to 1 Billion gallons of water...

Current State laws and regulations mandate that 'recycled water' 'treated water' not be introduced back into either rivers or any water aquifers. The community was designed to distribute the 120-130 million gallons of recycled water each and every year to water the Rancho Murieta Country Club (RMCC) two courses. This recycled water usage assists both the District on the required discharge of recycled water to the RMCC golf courses as spray fields. This also allows the RMCC to reduce the need for the usage of fresh water to be used for watering the golf courses. The current [water agreement with RMCC](#) expires in 2028.

In 2021 the RMCC formally requested a loan from the RMCCSD to assist in the purchase of pump to allow the continuation of watering the South golf course. This loan was approved at the District [January 2021 Board meeting](#). The Board understands the critical nature of the interconnection with the RMCC and the needs of the District, as it relates to recycled water usage and discharge. This specific loan request properly addressed by the Board to facilitate the need for monies to ensure the pumping of recycled water for both the watering and continued discharge of recycled water from the District. This process was conducted within the standardized process established by the State of California, as it relates to community service districts.

An example of the need for interoperability and cooperations thought the Ranch Murrieta community is in 2006 there was an illegal discharge of reclaimed water into the Cosumnes river. The lack of planning and preparation resulted in a cost to the District of \$1.2 million dollars. This was in the cost of fines imposed on the District from the State of California and immediate need for the usage of another spray field. This was to allow the continued requirements for the discharge of reclaimed water. Please click on the links to attached supporting documents.

Reclaimed Water to RMCC

[Agreement to provide recycled water to RMCC](#)

[Amendment to Agreement to provide recycled water](#)

[Water permits](#)



***FINDING #12: A PERCEIVED CONFLICT OF INTEREST EXISTS IN THE COMMUNITY DUE TO A CLOSE RELATIONSHIP BETWEEN THE DISTRICT, THE RMA AND THE RMCC AND THEIR RESPECTIVE BOARD MEMBERS.***

***GRAND JURY RECOMMENDATIONS RELATED TO THIS FINDING:***

***#R13: The District Board and staff should avoid perceptions of conflicts of interest in their fiduciary responsibilities to protect the interests of the District and its rate payers.***

***DISTRICT RESPONSE, IN BRIEF.***

The Board disagrees wholly with this finding. The Board complies with the District's Policy No. 2005-6 which prescribes ethical rules for Board Members and prohibits conflicts of interest. The Board is unaware of any legal conflicts of interest pertaining to Board Members, the homeowner's association's Board of Directors, and the country club.

***DISTRICT RESPONSE, DETAILED.***

The requirements of any local or state elected officials are to file a 'conflict of interest' report annually. Those residents that have spent any time within the community should understand how important the three organizations RMA, RMCC and RMCSD are to the overall community. The functions of each organization are clear as well as the roles and responsibilities of each organization's board of directors. The boards are solely responsible for their specific missions and fiscal responsibilities of each organization.

There are times when one organization can assist another organization. A perfect example is the usage/sharing of specialized equipment in times of localized flooding, evacuations, etc. The organizations have and will continue to be interconnected and work cooperatively to ensure the needs of the community are met.

# MEMORANDUM

Date: June 20, 2023  
To: Board of Directors  
From: Amelia Wilder, District Secretary  
Subject: Safety Center Rehabilitation CIP# 24-500-01 Update and Options

---

## RECOMMENDED ACTION

Staff recommend purchasing a refurbished modular building from Mobile Modular in the amount of \$226,637.45 with a 10% contingency for a total not to exceed \$249,301.19 to replace the existing safety center building.

## BACKGROUND

At the April 19, 2023 Board meeting Staff as instructed to investigate options, for leasing or purchasing a replacement mobile office space to house the Security Department with offices, a restroom, a small kitchen and a conference area. The existing unit was manufactured in 2004 and has sustained water damage from leaking windows over the years, resulting in mold and dry rot to the siding, beams, insulation and interior of the unit. The cost to repair the existing unit was determined to be too high and Staff obtained two bids to purchase similar mobile buildings.

## DISCUSSION ITEMS

Staff researched all available options and are providing the Board with the following information to assist with the recommended action:

Option 1 Purchase 24' X 50' refurbished mobile unit (Mobile Modular)	Option 2 Purchase 24' X 60' new mobile unit (Pacific Mobile Structures)
Purchase \$226,637.45 (Including 1 Overhang)	Purchase \$290,720.45

Staff also reached out to the following companies:

- Vesta Modular Purchased by Mobile Modular
- Prison Industries No response
- Wilscot Responded – No Quote
- 360 Mobile Office Responded – No available units
- Gordian Responded – No Quote

“Responded – No Quote” means that the company has not had time to produce a quote or is not capable of doing so. Some of the manufacturers do not have any units available to sell.

While both units include removal of the existing unit, delivery and set up of the new unit, skirting, labor, license and registration, neither quote includes gutters, lack of which are mainly responsible for the damage to the existing structure. There were a few differences between the two quotes:

**Mobile Modular:**

- 240 square feet smaller
- Refurbished
- New ADA ramp and stairs
- Will not be able to use the existing canopy – new canopy can be purchased for \$1,033
- Delivery in approximately 30 - 45 days

**Pacific Mobile Structures:**

- 240 square feet larger
- New Construction
- Use existing ADA ramp and stairs
- Will include the existing canopy
- Delivery in approximately 6 months

**RECOMMENDATION**

Staff recommend purchasing the unit from Mobile Modular for a total of \$249,301.19 including a 10% contingency. This will keep within the CIP Budget of \$250,000 and give the Security Department a new workspace.



Mobile Modular Management Corporation  
 5700 Las Positas Road  
 Livermore, CA 94551  
 Phone: (925) 606-9000  
 Fax: (925) 453-3201  
 www.mobilemodular.com

## Sale Quotation and Agreement

Quotation Number: 548765  
 Customer PO/Ref:  
 Date of Quote: 06/14/2023

### Sign up for the Easy Sale Option (see end of document for details)

Customer Information	Site Information	Mobile Modular Contact
Rancho Murieta Community Services Distri Sloughhouse, CA  Amelia Wilder awilder@rmcsd.com Phone: (916) 354-3703	Rancho Murieta Community Services Distri Rancho Murieta, CA 95683	<b>Questions?</b> Contact: Alex Sufi Alex.Sufi@mgrc.com Direct Phone: (707) 678-6100 Fax:

Product Information	Qty	Purchase Price	Extended Purchase Price	Taxable
Office, 24x50 HCD (NonStd) <i>Non-Standard Configuration. Size excludes 3' towbar.</i>	1	\$122,740.00	\$122,740.00	Y
ADA ramp	1	\$18,940.00	\$18,940.00	Y
Steps, Single Door Adjustable	1	\$1,120.00	\$1,120.00	Y
Charges Upon Delivery	Qty	Charge Each	Total One Time	Taxable
<b>Office, 24x50 HCD (NonStd)</b>				
Block and Level Building (A5) (PW) <i>Prevailing WageCert. Payroll</i>	1	\$5,862.00	\$5,862.00	N
Delivery Haulage 12 wide	2	\$1,135.00	\$2,270.00	N
Delivery Haulage Fuel 12 Wide	2	\$165.00	\$330.00	N
Delivery Haulage Permit 12 wide	2	\$175.00	\$350.00	N
Delivery Haulage Pilot 12 wide	2	\$560.00	\$1,120.00	N
Drawings, Wet Stamped, Building, Standard <i>Wet Stamped Engineered</i>	1	\$725.00	\$725.00	N
Essential Material Handling Fee	2	\$75.00	\$150.00	N
Fee, License or Registration for Sale	1	\$2,770.00	\$2,770.00	N
Install Foundation, Piers & Pads Only	1	\$2,860.00	\$2,860.00	Y
Install Foundation, Tiedown (Blvl) (PW) <i>Prevailing WageCert. Payroll</i>	16	\$236.00	\$3,776.00	Y
Installation, Skirting, Wood (PW) <i>Prevailing WageCert. Payroll</i>	148	\$28.00	\$4,144.00	Y
Modification	1	\$15,502.00	\$15,502.00	Y
Remove and dispose of existing building	1	\$27,578.00	\$27,578.00	Y
			<u>\$67,437.00</u>	

Total Estimated Charges	
Subtotal	\$210,237.00
Taxes	\$15,367.32
<b>Total Charges (including tax)</b>	<b>\$225,604.32</b>

**Special Notes**

**Additional Note:** Mobile Modular Sourcewell Contract#1208220-MMR. 24x60 Office Trailer Building One time charges, Delivery, Foundations (Block & Level), Installation, priced using RSMeans plus 17% Markup.

**Buildings containing a restroom(s):** Restrooms are not self-contained. Where applicable, manifolds are shipped loose and assembled and connected by others. Water & sewer stub-out locations may vary. Paper & soap dispensers, sanitary and trash receptacles are not provided.

**Block/Level:** Price assumes building is installed using Mobile Modular standard foundation. Mobile Modular assumes installation on the minimum foundation design criteria/tolerances. Additional material and labor charges apply for installing buildings above minimum

# Sale Quotation and Agreement

Quotation Number: 548765  
Customer PO/Ref:  
Date of Quote: 06/14/2023



foundation design criteria, raising buildings to meet specific finish floor elevations, raising building level to adjacent buildings, landings, walkways, transitions, etc.

**Delivery Date:** Delivery date will not be confirmed until Mobile Modular receives and approves the signed Agreement and all credit conditions have been met.

**Product Availability:** Product availability and delivery date are subject to product availability upon receipt of signed Agreement and/or credit approval.

**Pricing includes prevailing wage and certified payroll for installation work performed on site. Used building sale:** Quotation is for a used modular building sold in "as is" condition. Unless stated otherwise, MMMC will only perform a general cleaning & repair, reseal the roof, doors & windows, and test the electrical, mechanical & plumbing systems to ensure working condition at the time of delivery.

## Floor Plans

## Additional Information

- Quote is valid for 30 days.
- Customer's site must be dry, compacted, level and accessible by normal truck delivery. Costs to dolly, crane, forklift, etc. will be paid by customer. Unless noted, prices do not include permits, stairs, foundation systems, temporary power, skirting, engineering, taxes or utility hookups.
- Subject to equipment availability. Unless noted, equipment and related furnishings, finishes, accessories and appliances provided are previously leased and materials, dimensions, and specifications vary. Detailed specifications may be available upon request.
- This transaction is subject to prior credit approval and all terms, conditions, and attachments of MMMC's standard contract.
- Down Payment required on execution.
- **Sales Tax will be calculated based on the tax rate at the time of invoicing.**
- **Unless otherwise noted, prices do not include prevailing wages, Davis-Bacon wages, or other special or certified wages.**

*Thank you for contacting Mobile Modular.*

Mobile Modular is a division of McGrath RentCorp.  
548765, 06-14-2023 03:06 PM prod

# Sale Quotation and Agreement

Quotation Number: 548765  
Customer PO/Ref:  
Date of Quote: 06/14/2023



## Mobile Modular Easy Sale. Sign Me Up!

**Getting your modular building on its way has never been easier... and faster.** With Mobile Modular Easy Sale you can convert your Sale Quotation directly into a Sale Agreement by signing below. Once we receive your signed Easy Sale option, we'll finalize your building details and get your project on its way.

### Review and acknowledge agreement.

This Quotation is subject to Mobile Modular Management Corporation, a California corporation, herein known as seller (the "Seller"), credit approval of Customer, herein known as buyer (the "Buyer"). Seller does not warrant that the equipment meets any local or state code not specifically listed herein. Equipment is subject to availability. By signing below, customer accepts the terms of this quotation including prices and specifications, and instructs Seller to make appropriate arrangements for the preparation and delivery of the Equipment identified herein, and agrees that such signature constitutes customer's acceptance of and agreement to the Seller's Sale Agreement. Such sale, and customer's agreement thereto, is subject to Seller's standard terms and conditions located on the Seller's web site at ([www.mobilemodular.com/contractterms](http://www.mobilemodular.com/contractterms)) which are incorporated by reference herein. Customer may request a copy of the terms and conditions from Seller. No alterations, additions, exceptions, or changes to any Quotation or Agreement made by Buyer shall be effective against Seller, whether made hereon, contained in any printed form of Sale or elsewhere, unless accepted in writing by Seller. Any customer purchase order or other customer-provided document purporting to replace, supersede or supplement the terms and conditions of the Seller's Sale Agreement shall carry no force or effect except as an instrument of billing.

**Seller:**  
Mobile Modular Management Corporation

By: \_\_\_\_\_  
Name: \_\_\_\_\_  
Title: \_\_\_\_\_  
Date: \_\_\_\_\_

**Buyer:**  
Rancho Murieta Community Services Distri

Signature10: \_\_\_\_\_  
Print Name: \_\_\_\_\_  
Title: \_\_\_\_\_  
Date: \_\_\_\_\_



# TMP SERVICES

## 2929 KANSAS AVE.

### RIVERSIDE, CA 92507

#### (951) 213-3900

#### FAX (651) 213-3997

#### NOTES:

#### LOADS:

- RAMP LIVE LOAD = 100 PSF
- NO SNOW LOADING
- NO FLOOD LOADING
- WIND:
  - WIND SPEED = 130 MPH
  - RISK CATEGORY = II
  - EXPOSURE = C
  - $K_{zt} = 1.0$
  - WIND DESIGN PER ASCE 7-16 CHAPTER 29
- SEISMIC:
  - RISK CATEGORY = II
  - $I_e = 1.0$
  - $S_S = 3.73$
  - $S_1 = 1.30$
  - SITE CLASS = D
  - $C_S = 2.984$
  - $R = 3.25$  (ASCE 7-16 EQUATION 15.4-2)
  - $R = 3.25$  (ASCE 7-16 TABLE 15.4-1)
- ALLOWABLE SOIL BEARING = 1000 PSF
- THIS PC CANNOT BE USED IN WILDLAND URBAN INTERFACE (WUI) AREAS.

CODES: (TITLE 24 CODES)

2019 CALIFORNIA ADMINISTRATIVE CODE (CAC)...(PART 1, TITLE 24, CCR)

2019 CALIFORNIA BUILDING CODE (CBC), VOLUMES 1 AND 2 (PART 2, TITLE 24, CCR) (2018 EDITION INTERNATIONAL BUILDING CODE WITH 2019 CALIFORNIA AMENDMENTS)

2019 CALIFORNIA FIRE CODE (FCF), (PART 9, TITLE 24, CCR) (2019 EDITION INTERNATIONAL FIRE CODE WITH 2019 CALIFORNIA AMENDMENTS)

2019 CALIFORNIA GREEN CODE (CFC), (PART 9, TITLE 24, CCR)

2019 CALIFORNIA REFERENCED CODE, (PART 12, TITLE 24, CCR)

NFPA 13 2016  
NFPA 72 2016  
2019 CODE SECTIONS FOR APPLICABLE STANDARDS  
2019 CBC, CHAPTER 35

# STATE OF CALIFORNIA - 2018 IBC/2019 CBC

Sheet No.	Description	Dated	Revised
1	COVER SHEET	03 FEB 2020	
2	ACCESSIBLE RAMP ELEVATIONS & DETAILS	03 FEB 2020	
3	ACCESSIBLE RAMP DETAILS & NOTES	03 FEB 2020	
4	DETAILS & NOTES	03 FEB 2020	
5	ACCESSIBLE RAMP SWITCH BACK DETAILS	03 FEB 2020	
6	STAIRS - OPTIONAL	03 FEB 2020	
7	ACCESSIBLE RAMP OPTIONAL ALUMINUM DECK	03 FEB 2020	
8	ACCESSIBLE RAMP ELEVATIONS & PLAN VIEWS	03 FEB 2020	

Sheet No.	Description	Dated	Revised
1A	COVER SHEET	03 FEB 2020	
2A	ACCESSIBLE RAMP ELEVATIONS & DETAILS	03 FEB 2020	
3A	ACCESSIBLE RAMP DETAILS & NOTES	03 FEB 2020	
4A	DETAILS & NOTES	03 FEB 2020	
5A	ACCESSIBLE RAMP SWITCH BACK DETAILS	03 FEB 2020	
6A	STAIRS - OPTIONAL	03 FEB 2020	
7A	ACCESSIBLE RAMP OPTIONAL ALUMINUM DECK	03 FEB 2020	
8A	ACCESSIBLE RAMP ELEVATIONS & PLAN VIEWS	03 FEB 2020	

**DSA 103-19- LISTING OF STRUCTURAL TESTS & SPECIAL INSPECTIONS (Steel and Aluminum), 2019 CBC**

Application Number: 04-119501  
School Name: ACCESSIBLE STEEL RAMP LANDING STAIRS  
School District: TEMPE SERVICES INC.  
Accession Number: 04-119501  
Increment Number: 2021-09-03 18:44:27

**2019 CBC**

IMPORTANT: This form is only a summary list of structural tests and some of the special inspections required for the project. Generally, the structural tests and special inspections noted on this form are those that will be performed by the Geotechnical Engineer of Record, Laboratory of Record, or Special Inspector. The actual complete test and inspection program must be performed as detailed on the DSA approved documents. The agenda at the bottom of this form identifies what NOT to do for DSA requirements for special inspection or structural testing. The project inspector is responsible for providing inspection of all facets of construction, including but not limited to, special inspections not listed on this form such as structural wood framing, high-strength wood diaphragms, cold-formed steel framing, anchorage of non-structural components, etc., per Title 24, Part 2, Chapter 17A (2019 CBC).

NOTE: Undefined section and table references found in this document are from the CBC or California Building Code.

KEY TO COLUMNS	PERFORMED BY
1. TYPE	CE - indicates that the special inspection shall be performed by a registered geotechnical engineer or his or her authorized representative.
Continuance - indicates that a continuous special inspection is required.	LOI - indicates that the test or special inspection shall be performed by a testing laboratory approved by the DSA (Laboratory Evaluation and Acceptance (LEA) Program, per CBC Section 4.10.6).
Periodic - indicates that a periodic special inspection is required.	PI - indicates that the special inspection may be performed by a project inspector when specifically approved by DSA.
Test - indicates that a test is required.	SI - indicates that the special inspection shall be performed by an appropriately qualified/approved special inspector.

DGS DSA 103-19 (Revised 07/16/2020)  
DIVISION OF THE STATE ARCHITECT DEPARTMENT OF GENERAL SERVICES STATE OF CALIFORNIA Page 4 of 12

**DSA 103-19- LISTING OF STRUCTURAL TESTS & SPECIAL INSPECTIONS (Steel and Aluminum), 2019 CBC**

Application Number: 04-119501  
School Name: ACCESSIBLE STEEL RAMP LANDING STAIRS  
School District: TEMPE SERVICES INC.  
Accession Number: 04-119501  
Increment Number: 2021-09-03 18:44:27

**17. STRUCTURAL STEEL, COLD-FORMED STEEL AND ALUMINUM USED FOR STRUCTURAL PURPOSES**

Test or Special Inspection	Type	Performed By	Code Reference and Notes
a. Verify identification of all materials and AISI certificates indicate material properties that comply with requirements.	Periodic	SI	Table 1705A.2.1 Item 3a, 3b, 3c, 2020A.1, AISI 900-16 Section A3.1 & A3.2, AISI 900-16 Section A3.3 & A3.4, AISI 900-16 Section A3.5, AISI 900-16 Section A3.6, AISI 900-16 Section A3.7, AISI 900-16 Section A3.8, AISI 900-16 Section A3.9, AISI 900-16 Section A3.10, AISI 900-16 Section A3.11, AISI 900-16 Section A3.12, AISI 900-16 Section A3.13, AISI 900-16 Section A3.14, AISI 900-16 Section A3.15, AISI 900-16 Section A3.16, AISI 900-16 Section A3.17, AISI 900-16 Section A3.18, AISI 900-16 Section A3.19, AISI 900-16 Section A3.20, AISI 900-16 Section A3.21, AISI 900-16 Section A3.22, AISI 900-16 Section A3.23, AISI 900-16 Section A3.24, AISI 900-16 Section A3.25, AISI 900-16 Section A3.26, AISI 900-16 Section A3.27, AISI 900-16 Section A3.28, AISI 900-16 Section A3.29, AISI 900-16 Section A3.30, AISI 900-16 Section A3.31, AISI 900-16 Section A3.32, AISI 900-16 Section A3.33, AISI 900-16 Section A3.34, AISI 900-16 Section A3.35, AISI 900-16 Section A3.36, AISI 900-16 Section A3.37, AISI 900-16 Section A3.38, AISI 900-16 Section A3.39, AISI 900-16 Section A3.40, AISI 900-16 Section A3.41, AISI 900-16 Section A3.42, AISI 900-16 Section A3.43, AISI 900-16 Section A3.44, AISI 900-16 Section A3.45, AISI 900-16 Section A3.46, AISI 900-16 Section A3.47, AISI 900-16 Section A3.48, AISI 900-16 Section A3.49, AISI 900-16 Section A3.50, AISI 900-16 Section A3.51, AISI 900-16 Section A3.52, AISI 900-16 Section A3.53, AISI 900-16 Section A3.54, AISI 900-16 Section A3.55, AISI 900-16 Section A3.56, AISI 900-16 Section A3.57, AISI 900-16 Section A3.58, AISI 900-16 Section A3.59, AISI 900-16 Section A3.60, AISI 900-16 Section A3.61, AISI 900-16 Section A3.62, AISI 900-16 Section A3.63, AISI 900-16 Section A3.64, AISI 900-16 Section A3.65, AISI 900-16 Section A3.66, AISI 900-16 Section A3.67, AISI 900-16 Section A3.68, AISI 900-16 Section A3.69, AISI 900-16 Section A3.70, AISI 900-16 Section A3.71, AISI 900-16 Section A3.72, AISI 900-16 Section A3.73, AISI 900-16 Section A3.74, AISI 900-16 Section A3.75, AISI 900-16 Section A3.76, AISI 900-16 Section A3.77, AISI 900-16 Section A3.78, AISI 900-16 Section A3.79, AISI 900-16 Section A3.80, AISI 900-16 Section A3.81, AISI 900-16 Section A3.82, AISI 900-16 Section A3.83, AISI 900-16 Section A3.84, AISI 900-16 Section A3.85, AISI 900-16 Section A3.86, AISI 900-16 Section A3.87, AISI 900-16 Section A3.88, AISI 900-16 Section A3.89, AISI 900-16 Section A3.90, AISI 900-16 Section A3.91, AISI 900-16 Section A3.92, AISI 900-16 Section A3.93, AISI 900-16 Section A3.94, AISI 900-16 Section A3.95, AISI 900-16 Section A3.96, AISI 900-16 Section A3.97, AISI 900-16 Section A3.98, AISI 900-16 Section A3.99, AISI 900-16 Section A3.100, AISI 900-16 Section A3.101, AISI 900-16 Section A3.102, AISI 900-16 Section A3.103, AISI 900-16 Section A3.104, AISI 900-16 Section A3.105, AISI 900-16 Section A3.106, AISI 900-16 Section A3.107, AISI 900-16 Section A3.108, AISI 900-16 Section A3.109, AISI 900-16 Section A3.110, AISI 900-16 Section A3.111, AISI 900-16 Section A3.112, AISI 900-16 Section A3.113, AISI 900-16 Section A3.114, AISI 900-16 Section A3.115, AISI 900-16 Section A3.116, AISI 900-16 Section A3.117, AISI 900-16 Section A3.118, AISI 900-16 Section A3.119, AISI 900-16 Section A3.120, AISI 900-16 Section A3.121, AISI 900-16 Section A3.122, AISI 900-16 Section A3.123, AISI 900-16 Section A3.124, AISI 900-16 Section A3.125, AISI 900-16 Section A3.126, AISI 900-16 Section A3.127, AISI 900-16 Section A3.128, AISI 900-16 Section A3.129, AISI 900-16 Section A3.130, AISI 900-16 Section A3.131, AISI 900-16 Section A3.132, AISI 900-16 Section A3.133, AISI 900-16 Section A3.134, AISI 900-16 Section A3.135, AISI 900-16 Section A3.136, AISI 900-16 Section A3.137, AISI 900-16 Section A3.138, AISI 900-16 Section A3.139, AISI 900-16 Section A3.140, AISI 900-16 Section A3.141, AISI 900-16 Section A3.142, AISI 900-16 Section A3.143, AISI 900-16 Section A3.144, AISI 900-16 Section A3.145, AISI 900-16 Section A3.146, AISI 900-16 Section A3.147, AISI 900-16 Section A3.148, AISI 900-16 Section A3.149, AISI 900-16 Section A3.150, AISI 900-16 Section A3.151, AISI 900-16 Section A3.152, AISI 900-16 Section A3.153, AISI 900-16 Section A3.154, AISI 900-16 Section A3.155, AISI 900-16 Section A3.156, AISI 900-16 Section A3.157, AISI 900-16 Section A3.158, AISI 900-16 Section A3.159, AISI 900-16 Section A3.160, AISI 900-16 Section A3.161, AISI 900-16 Section A3.162, AISI 900-16 Section A3.163, AISI 900-16 Section A3.164, AISI 900-16 Section A3.165, AISI 900-16 Section A3.166, AISI 900-16 Section A3.167, AISI 900-16 Section A3.168, AISI 900-16 Section A3.169, AISI 900-16 Section A3.170, AISI 900-16 Section A3.171, AISI 900-16 Section A3.172, AISI 900-16 Section A3.173, AISI 900-16 Section A3.174, AISI 900-16 Section A3.175, AISI 900-16 Section A3.176, AISI 900-16 Section A3.177, AISI 900-16 Section A3.178, AISI 900-16 Section A3.179, AISI 900-16 Section A3.180, AISI 900-16 Section A3.181, AISI 900-16 Section A3.182, AISI 900-16 Section A3.183, AISI 900-16 Section A3.184, AISI 900-16 Section A3.185, AISI 900-16 Section A3.186, AISI 900-16 Section A3.187, AISI 900-16 Section A3.188, AISI 900-16 Section A3.189, AISI 900-16 Section A3.190, AISI 900-16 Section A3.191, AISI 900-16 Section A3.192, AISI 900-16 Section A3.193, AISI 900-16 Section A3.194, AISI 900-16 Section A3.195, AISI 900-16 Section A3.196, AISI 900-16 Section A3.197, AISI 900-16 Section A3.198, AISI 900-16 Section A3.199, AISI 900-16 Section A3.200, AISI 900-16 Section A3.201, AISI 900-16 Section A3.202, AISI 900-16 Section A3.203, AISI 900-16 Section A3.204, AISI 900-16 Section A3.205, AISI 900-16 Section A3.206, AISI 900-16 Section A3.207, AISI 900-16 Section A3.208, AISI 900-16 Section A3.209, AISI 900-16 Section A3.210, AISI 900-16 Section A3.211, AISI 900-16 Section A3.212, AISI 900-16 Section A3.213, AISI 900-16 Section A3.214, AISI 900-16 Section A3.215, AISI 900-16 Section A3.216, AISI 900-16 Section A3.217, AISI 900-16 Section A3.218, AISI 900-16 Section A3.219, AISI 900-16 Section A3.220, AISI 900-16 Section A3.221, AISI 900-16 Section A3.222, AISI 900-16 Section A3.223, AISI 900-16 Section A3.224, AISI 900-16 Section A3.225, AISI 900-16 Section A3.226, AISI 900-16 Section A3.227, AISI 900-16 Section A3.228, AISI 900-16 Section A3.229, AISI 900-16 Section A3.230, AISI 900-16 Section A3.231, AISI 900-16 Section A3.232, AISI 900-16 Section A3.233, AISI 900-16 Section A3.234, AISI 900-16 Section A3.235, AISI 900-16 Section A3.236, AISI 900-16 Section A3.237, AISI 900-16 Section A3.238, AISI 900-16 Section A3.239, AISI 900-16 Section A3.240, AISI 900-16 Section A3.241, AISI 900-16 Section A3.242, AISI 900-16 Section A3.243, AISI 900-16 Section A3.244, AISI 900-16 Section A3.245, AISI 900-16 Section A3.246, AISI 900-16 Section A3.247, AISI 900-16 Section A3.248, AISI 900-16 Section A3.249, AISI 900-16 Section A3.250, AISI 900-16 Section A3.251, AISI 900-16 Section A3.252, AISI 900-16 Section A3.253, AISI 900-16 Section A3.254, AISI 900-16 Section A3.255, AISI 900-16 Section A3.256, AISI 900-16 Section A3.257, AISI 900-16 Section A3.258, AISI 900-16 Section A3.259, AISI 900-16 Section A3.260, AISI 900-16 Section A3.261, AISI 900-16 Section A3.262, AISI 900-16 Section A3.263, AISI 900-16 Section A3.264, AISI 900-16 Section A3.265, AISI 900-16 Section A3.266, AISI 900-16 Section A3.267, AISI 900-16 Section A3.268, AISI 900-16 Section A3.269, AISI 900-16 Section A3.270, AISI 900-16 Section A3.271, AISI 900-16 Section A3.272, AISI 900-16 Section A3.273, AISI 900-16 Section A3.274, AISI 900-16 Section A3.275, AISI 900-16 Section A3.276, AISI 900-16 Section A3.277, AISI 900-16 Section A3.278, AISI 900-16 Section A3.279, AISI 900-16 Section A3.280, AISI 900-16 Section A3.281, AISI 900-16 Section A3.282, AISI 900-16 Section A3.283, AISI 900-16 Section A3.284, AISI 900-16 Section A3.285, AISI 900-16 Section A3.286, AISI 900-16 Section A3.287, AISI 900-16 Section A3.288, AISI 900-16 Section A3.289, AISI 900-16 Section A3.290, AISI 900-16 Section A3.291, AISI 900-16 Section A3.292, AISI 900-16 Section A3.293, AISI 900-16 Section A3.294, AISI 900-16 Section A3.295, AISI 900-16 Section A3.296, AISI 900-16 Section A3.297, AISI 900-16 Section A3.298, AISI 900-16 Section A3.299, AISI 900-16 Section A3.300, AISI 900-16 Section A3.301, AISI 900-16 Section A3.302, AISI 900-16 Section A3.303, AISI 900-16 Section A3.304, AISI 900-16 Section A3.305, AISI 900-16 Section A3.306, AISI 900-16 Section A3.307, AISI 900-16 Section A3.308, AISI 900-16 Section A3.309, AISI 900-16 Section A3.310, AISI 900-16 Section A3.311, AISI 900-16 Section A3.312, AISI 900-16 Section A3.313, AISI 900-16 Section A3.314, AISI 900-16 Section A3.315, AISI 900-16 Section A3.316, AISI 900-16 Section A3.317, AISI 900-16 Section A3.318, AISI 900-16 Section A3.319, AISI 900-16 Section A3.320, AISI 900-16 Section A3.321, AISI 900-16 Section A3.322, AISI 900-16 Section A3.323, AISI 900-16 Section A3.324, AISI 900-16 Section A3.325, AISI 900-16 Section A3.326, AISI 900-16 Section A3.327, AISI 900-16 Section A3.328, AISI 900-16 Section A3.329, AISI 900-16 Section A3.330, AISI 900-16 Section A3.331, AISI 900-16 Section A3.332, AISI 900-16 Section A3.333, AISI 900-16 Section A3.334, AISI 900-16 Section A3.335, AISI 900-16 Section A3.336, AISI 900-16 Section A3.337, AISI 900-16 Section A3.338, AISI 900-16 Section A3.339, AISI 900-16 Section A3.340, AISI 900-16 Section A3.341, AISI 900-16 Section A3.342, AISI 900-16 Section A3.343, AISI 900-16 Section A3.344, AISI 900-16 Section A3.345, AISI 900-16 Section A3.346, AISI 900-16 Section A3.347, AISI 900-16 Section A3.348, AISI 900-16 Section A3.349, AISI 900-16 Section A3.350, AISI 900-16 Section A3.351, AISI 900-16 Section A3.352, AISI 900-16 Section A3.353, AISI 900-16 Section A3.354, AISI 900-16 Section A3.355, AISI 900-16 Section A3.356, AISI 900-16 Section A3.357, AISI 900-16 Section A3.358, AISI 900-16 Section A3.359, AISI 900-16 Section A3.360, AISI 900-16 Section A3.361, AISI 900-16 Section A3.362, AISI 900-16 Section A3.363, AISI 900-16 Section A3.364, AISI 900-16 Section A3.365, AISI 900-16 Section A3.366, AISI 900-16 Section A3.367, AISI 900-16 Section A3.368, AISI 900-16 Section A3.369, AISI 900-16 Section A3.370, AISI 900-16 Section A3.371, AISI 900-16 Section A3.372, AISI 900-16 Section A3.373, AISI 900-16 Section A3.374, AISI 900-16 Section A3.375, AISI 900-16 Section A3.376, AISI 900-16 Section A3.377, AISI 900-16 Section A3.378, AISI 900-16 Section A3.379, AISI 900-16 Section A3.380, AISI 900-16 Section A3.381, AISI 900-16 Section A3.382, AISI 900-16 Section A3.383, AISI 900-16 Section A3.384, AISI 900-16 Section A3.385, AISI 900-16 Section A3.386, AISI 900-16 Section A3.387, AISI 900-16 Section A3.388, AISI 900-16 Section A3.389, AISI 900-16 Section A3.390, AISI 900-16 Section A3.391, AISI 900-16 Section A3.392, AISI 900-16 Section A3.393, AISI 900-16 Section A3.394, AISI 900-16 Section A3.395, AISI 900-16 Section A3.396, AISI 900-16 Section A3.397, AISI 900-16 Section A3.398, AISI 900-16 Section A3.399, AISI 900-16 Section A3.400, AISI 900-16 Section A3.401, AISI 900-16 Section A3.402, AISI 900-16 Section A3.403, AISI 900-16 Section A3.404, AISI 900-16 Section A3.405, AISI 900-16 Section A3.406, AISI 900-16 Section A3.407, AISI 900-16 Section A3.408, AISI 900-16 Section A3.409, AISI 900-16 Section A3.410, AISI 900-16 Section A3.411, AISI 900-16 Section A3.412, AISI 900-16 Section A3.413, AISI 900-16 Section A3.414, AISI 900-16 Section A3.415, AISI 900-16 Section A3.416, AISI 900-16 Section A3.417, AISI 900-16 Section A3.418, AISI 900-16 Section A3.419, AISI 900-16 Section A3.420, AISI 900-16 Section A3.421, AISI 900-16 Section A3.422, AISI 900-16 Section A3.423, AISI 900-16 Section A3.424, AISI 900-16 Section A3.425, AISI 900-16 Section A3.426, AISI 900-16 Section A3.427, AISI 900-16 Section A3.428, AISI 900-16 Section A3.429, AISI 900-16 Section A3.430, AISI 900-16 Section A3.431, AISI 900-16 Section A3.432, AISI 900-16 Section A3.433, AISI 900-16 Section A3.434, AISI 900-16 Section A3.435, AISI 900-16 Section A3.436, AISI 900-16 Section A3.437, AISI 900-16 Section A3.438, AISI 900-16 Section A3.439, AISI 900-16 Section A3.440, AISI 900-16 Section A3.441, AISI 900-16 Section A3.442, AISI 900-16 Section A3.443, AISI 900-16 Section A3.444, AISI 900-16 Section A3.445, AISI 900-16 Section A3.446, AISI 900-16 Section A3.447, AISI 900-16 Section A3.448, AISI 900-16 Section A3.449, AISI 900-16 Section A3.450, AISI 900-16 Section A3.451, AISI 900-16 Section A3.452, AISI 900-16 Section A3.453, AISI 900-16 Section A3.454, AISI 900-16 Section A3.455, AISI 900-16 Section A3.456, AISI 900-16 Section A3.457, AISI 900-16 Section A3.458, AISI 900-16 Section A3.459, AISI 900-16 Section A3.460, AISI 900-16 Section A3.461, AISI 900-16 Section A3.462, AISI 900-16 Section A3.463, AISI 900-16 Section A3.464, AISI 900-16 Section A3.465, AISI 900-16 Section A3.466, AISI 900-16 Section A3.467, AISI 900-16 Section A3.468, AISI 900-16 Section A3.469, AISI 900-16 Section A3.470, AISI 900-16 Section A3.471, AISI 900-16 Section A3.472, AISI 900-16 Section A3.473, AISI 900-16 Section A3.474, AISI 900-16 Section A3.475, AISI 900-16 Section A3.476, AISI 900-16 Section A3.477, AISI 900-16 Section A3.478, AISI 900-16 Section A3.479, AISI 900-16 Section A3.480, AISI 900-16 Section A3.481, AISI 900-16 Section A3.482, AISI 900-16 Section A3.483, AISI 900-16 Section A3.484, AISI 900-16 Section A3.485, AISI 900-16 Section A3.486, AISI 900-16 Section A3.487, AISI 900-16 Section A3.488, AISI 900-16 Section A3.489, AISI 900-16 Section A3.490, AISI 900-16 Section A3.491, AISI 900-16 Section A3.492, AISI 900-16 Section A3.493, AISI 900-16 Section A3.494, AISI 900-16 Section A3.495, AISI 900-16 Section A3.496, AISI 900-16 Section A3.497, AISI 900-16 Section A3.498, AISI 900-16 Section A3.499, AISI 900-16 Section A3.500, AISI 900-16 Section A3.501, AISI 900-16 Section A3.502, AISI 900-16 Section A3.503, AISI 900-16 Section A3.504, AISI 900-16 Section A3.505, AISI 900-16 Section A3.506, AISI 900-16 Section A3.507, AISI 900-16 Section A3.508, AISI 900-16 Section A3.509, AISI 900-16 Section A3.510, AISI 900-16 Section A3.511, AISI 900-16 Section A3.512, AISI 900-16 Section A3.513, AISI 900-16 Section A3.514, AISI 900-16 Section A3.515, AISI 900-16 Section A3.516, AISI 900-16 Section A3.517, AISI 900-16 Section A3.518, AISI 900-16 Section A3.519, AISI 900-16 Section A3.520, AISI 900-16 Section A3.521, AISI 900-16 Section A3.522, AISI 900-16 Section A3.523, AISI 900-16 Section A3.524, AISI 900-16 Section A3.525, AISI 900-16 Section A3.526, AISI 900-16 Section A3.527, AISI 900-16 Section A3.528, AISI 900-16 Section A3.529, AISI 900-16 Section A3.530, AISI 900-16 Section A3.531, AISI 900-16 Section A3.532, AISI 900-16 Section A3.533, AISI 900-16 Section A3.534, AISI 900-16 Section A3.535, AISI 900-16 Section A3.536, AISI 900-16 Section A3.537, AISI 900-16 Section A3.538, AISI 900-16 Section A3.539, AISI 900-16 Section A3.540, AISI 900-16 Section A3.541, AISI 900-16 Section A3.542, AISI 900-16 Section A3.543, AISI 900-16 Section A3.544, AISI 900-16 Section A3.545, AISI 900-16 Section A3.546, AISI 900-16 Section A3.547, AISI 900-16 Section A3.548, AISI 900-16 Section A3.549, AISI 900-16 Section A3.55



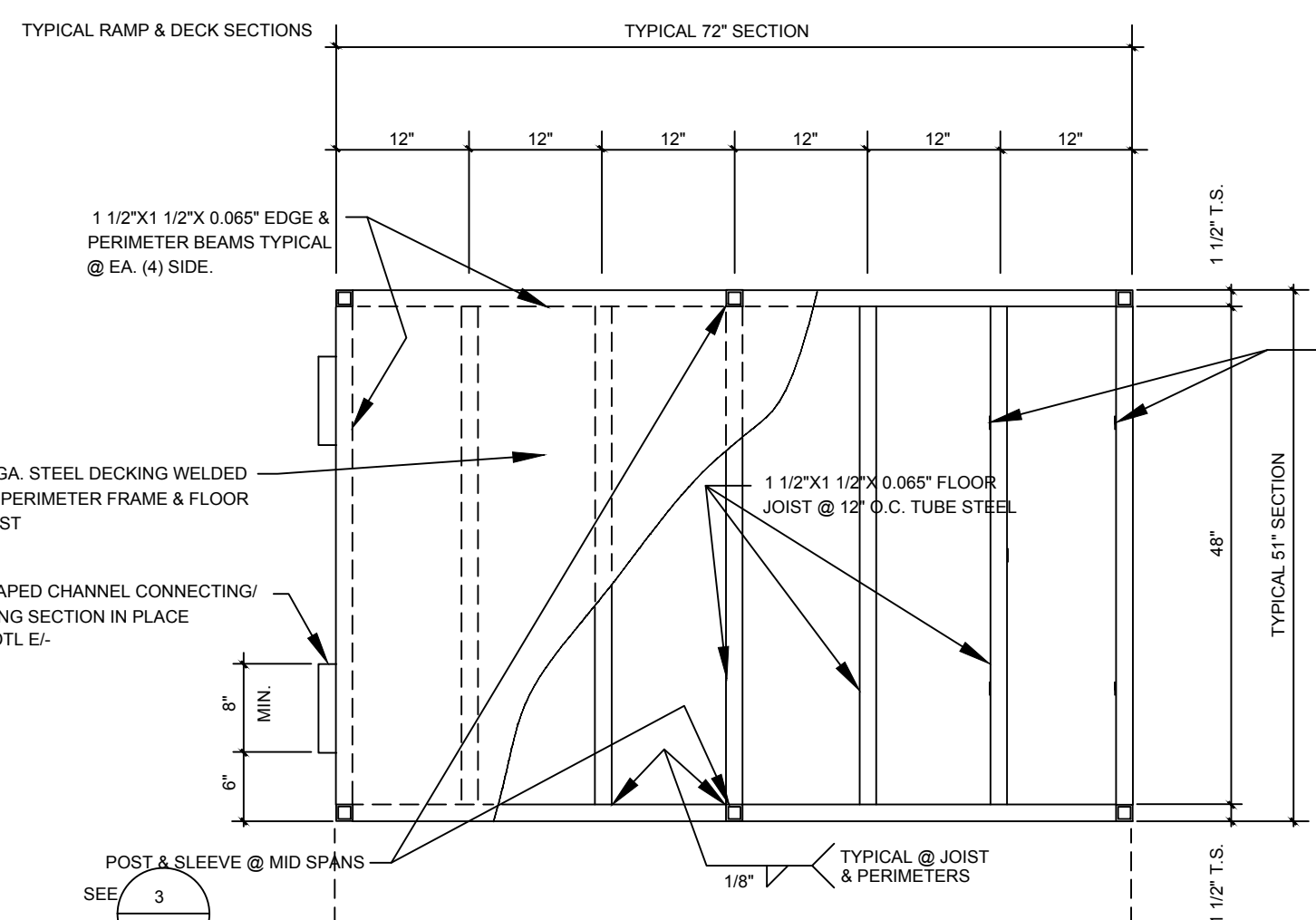

**TYPICAL 6'-0" RAMP SECTION PLAN VIEW**

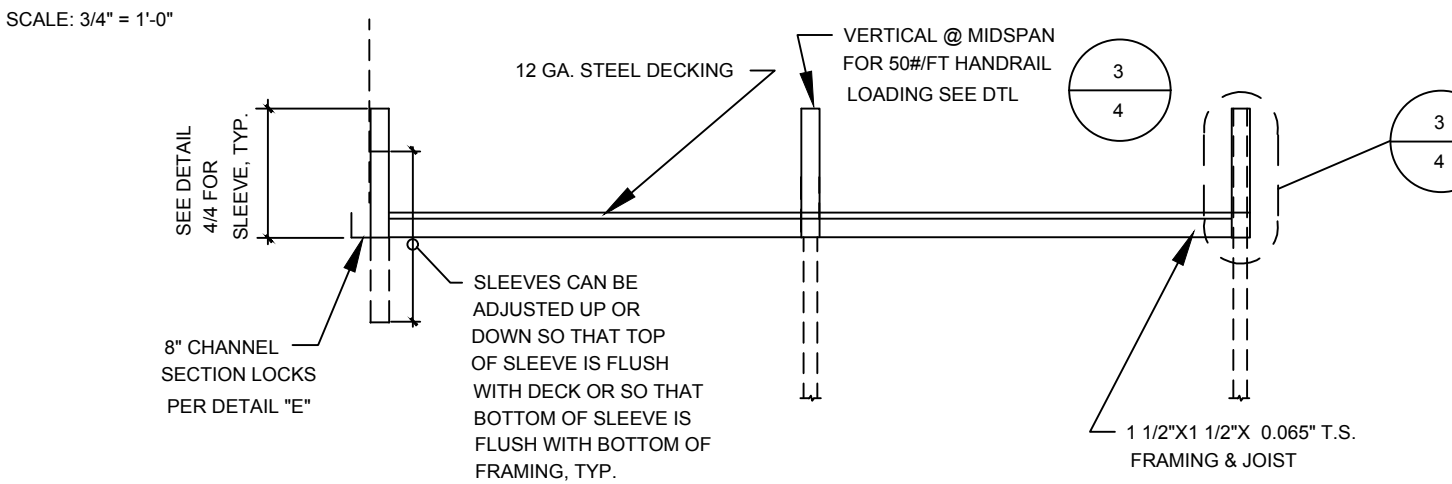

**SIDE/END VIEW OF LEVEL DECK SECTION**

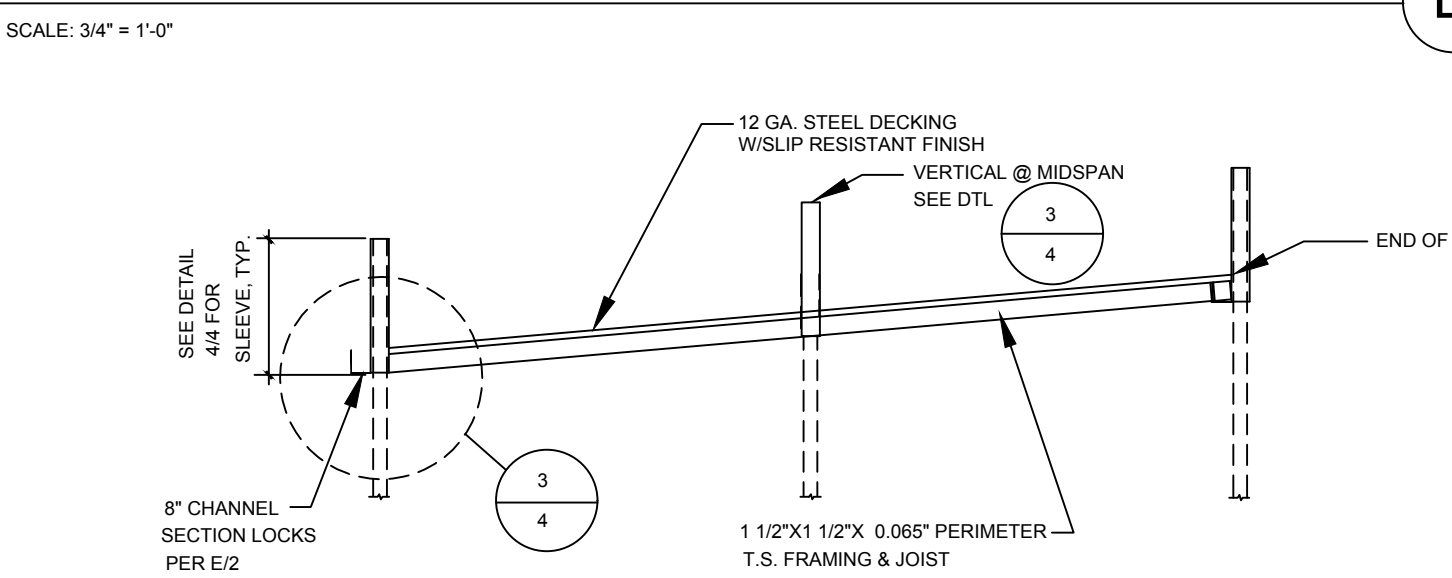

**SIDE VIEW OF SLOPING RAMP SECTION TYPICAL**

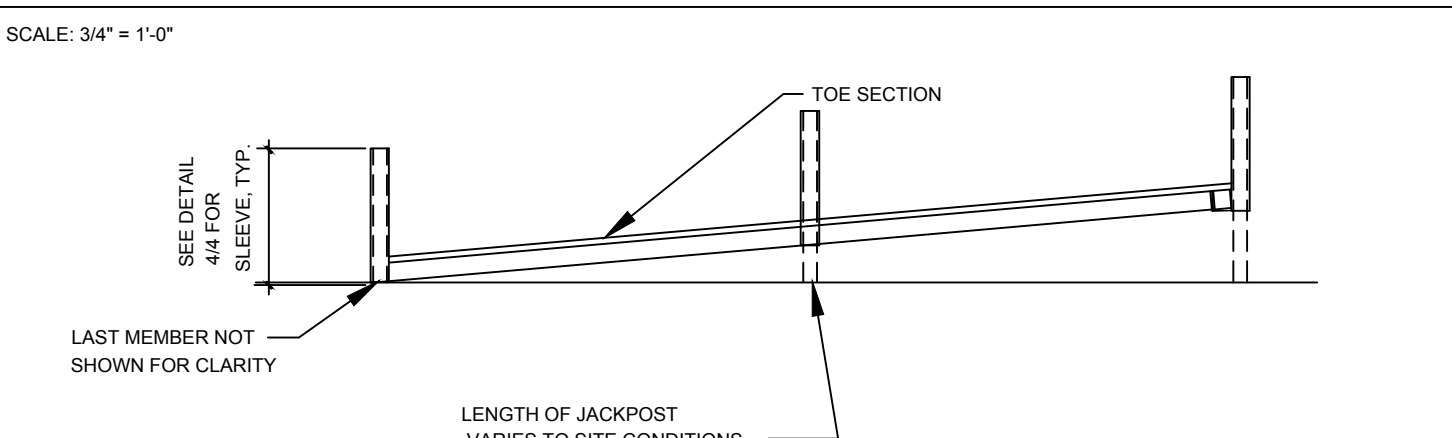

**TOE SECTION**

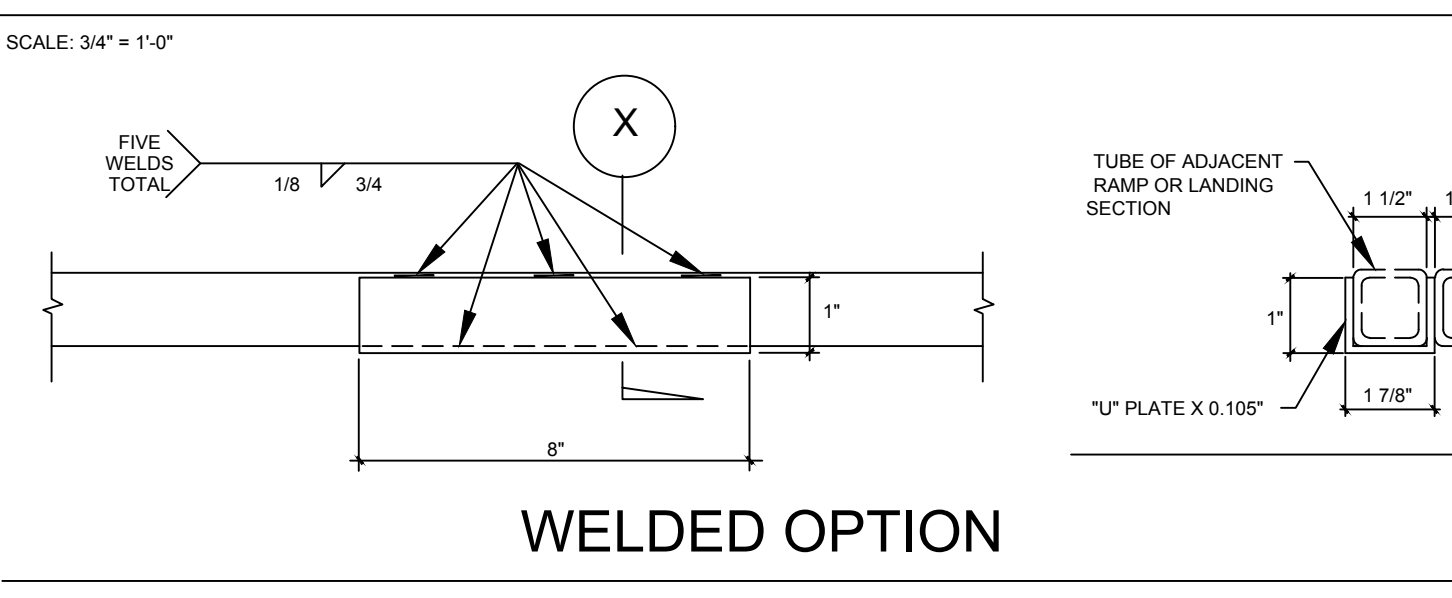

**8" CHANNEL SECTION**

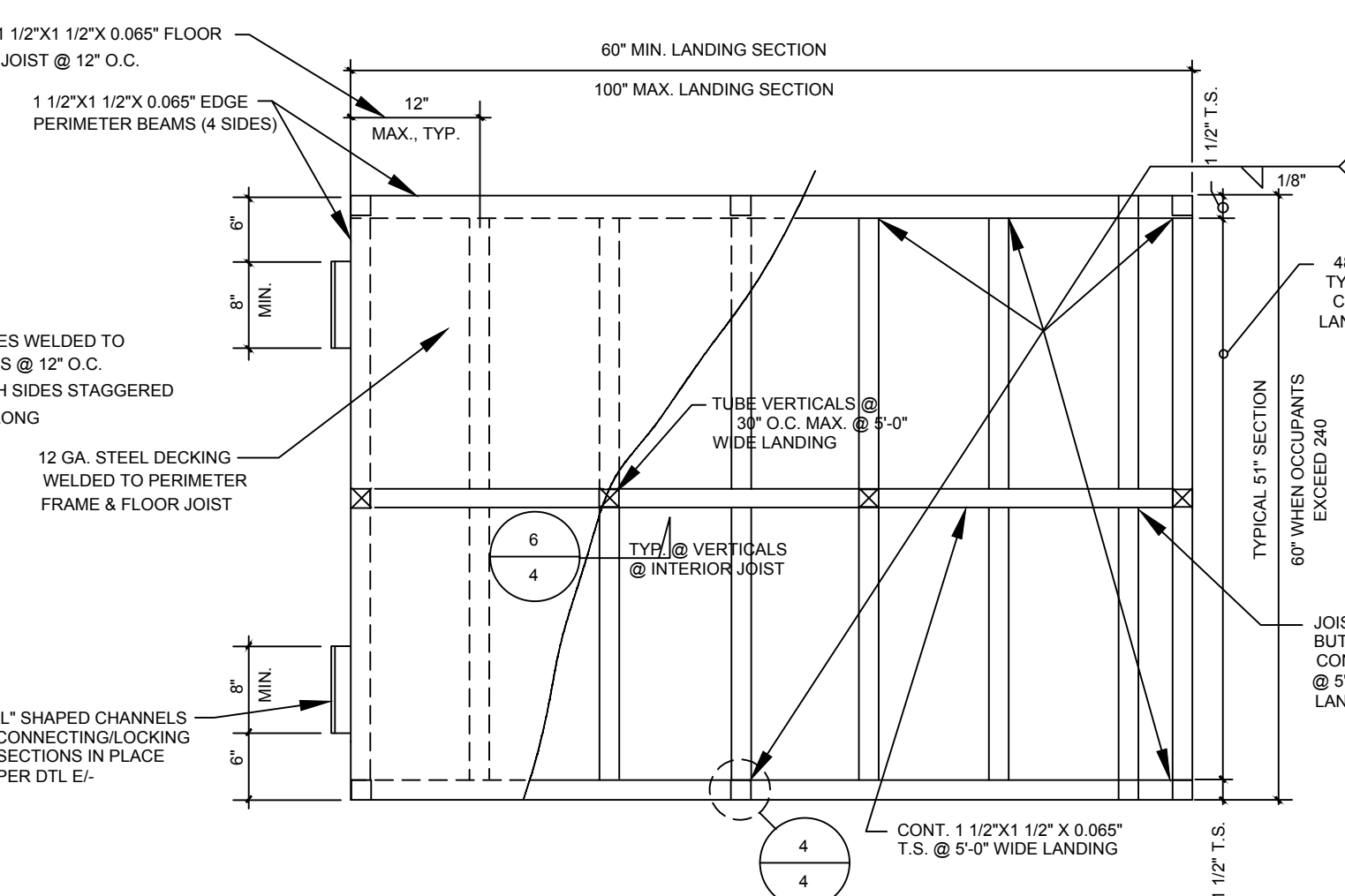

**TYPICAL 7'-0" X 5'-0" LANDING**

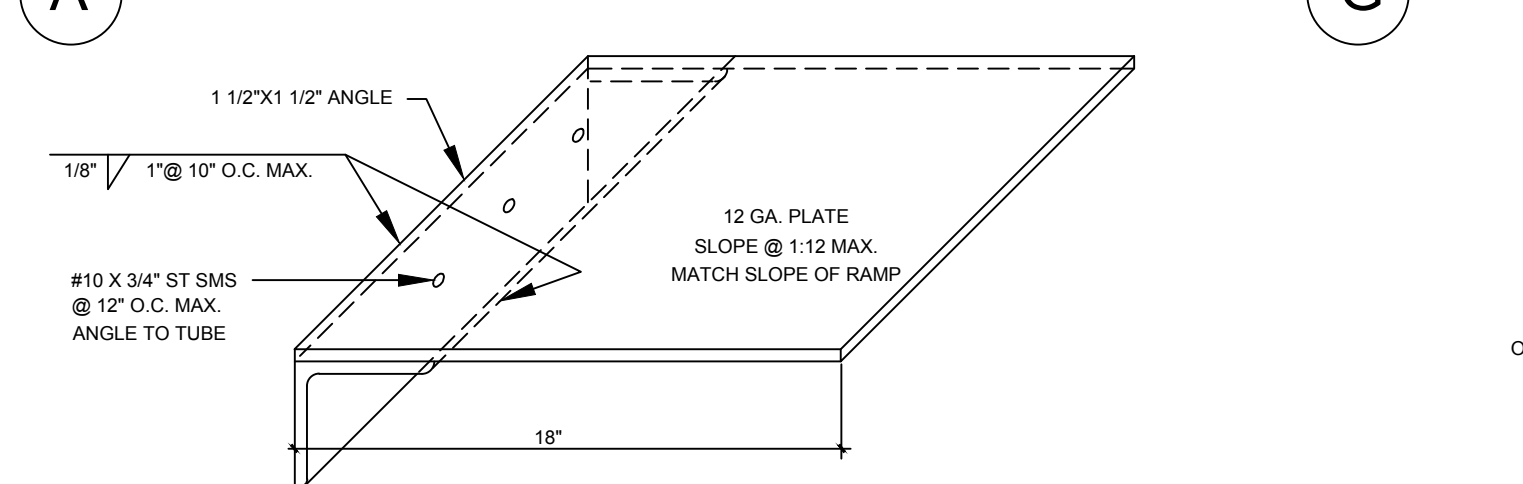

**OPTIONAL TOE PLATE**

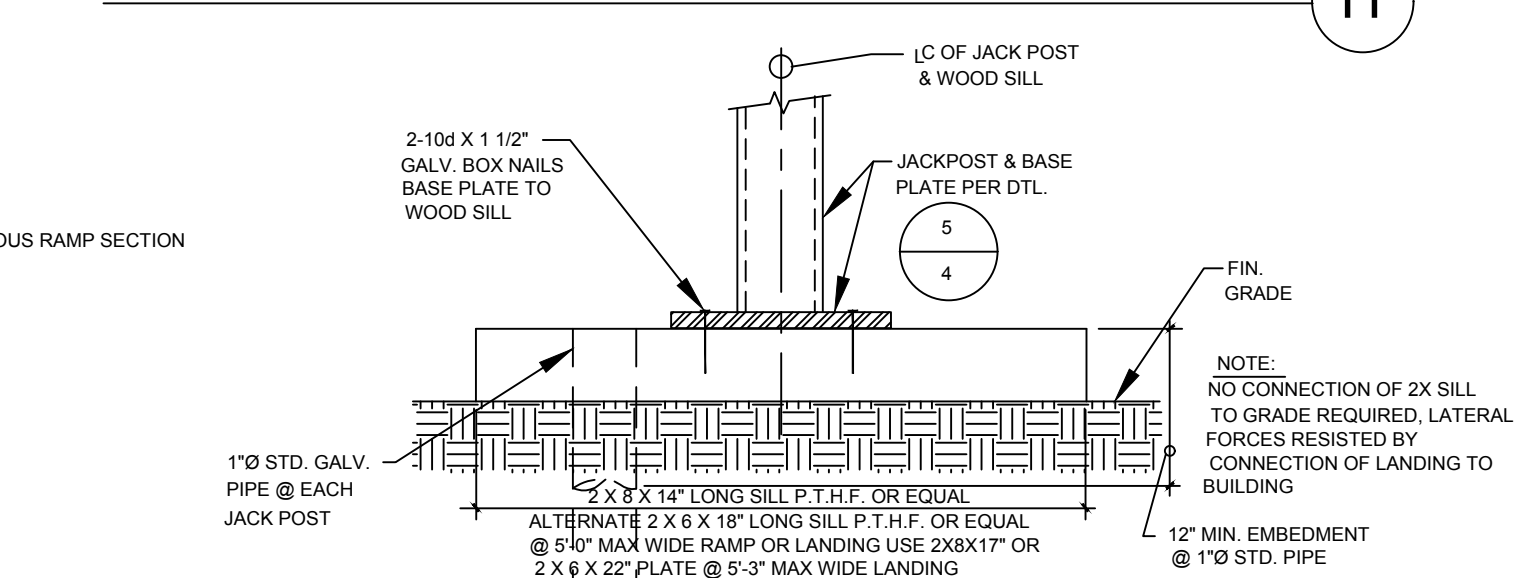

**ALTERNATE WOOD SILLS @ JACK POST TO GRADE WHERE CONCRETE OR AC PAVING DOES NOT OCCUR**

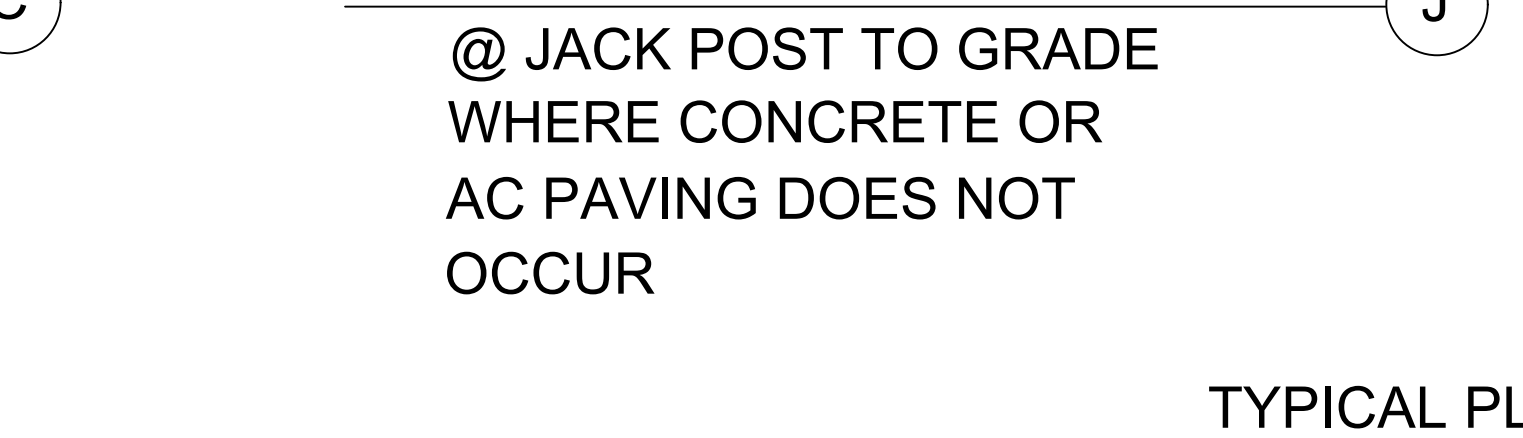

**JACK POST TO PAVING**

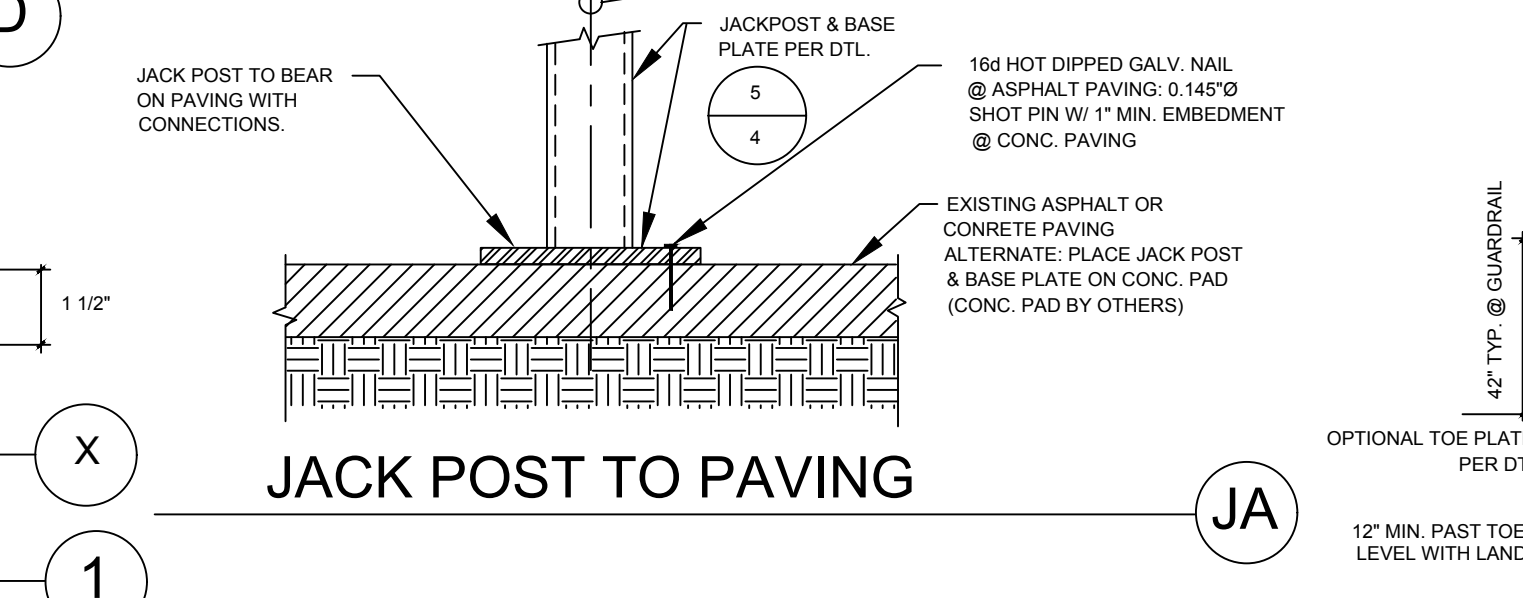

**FILLER DETAIL**

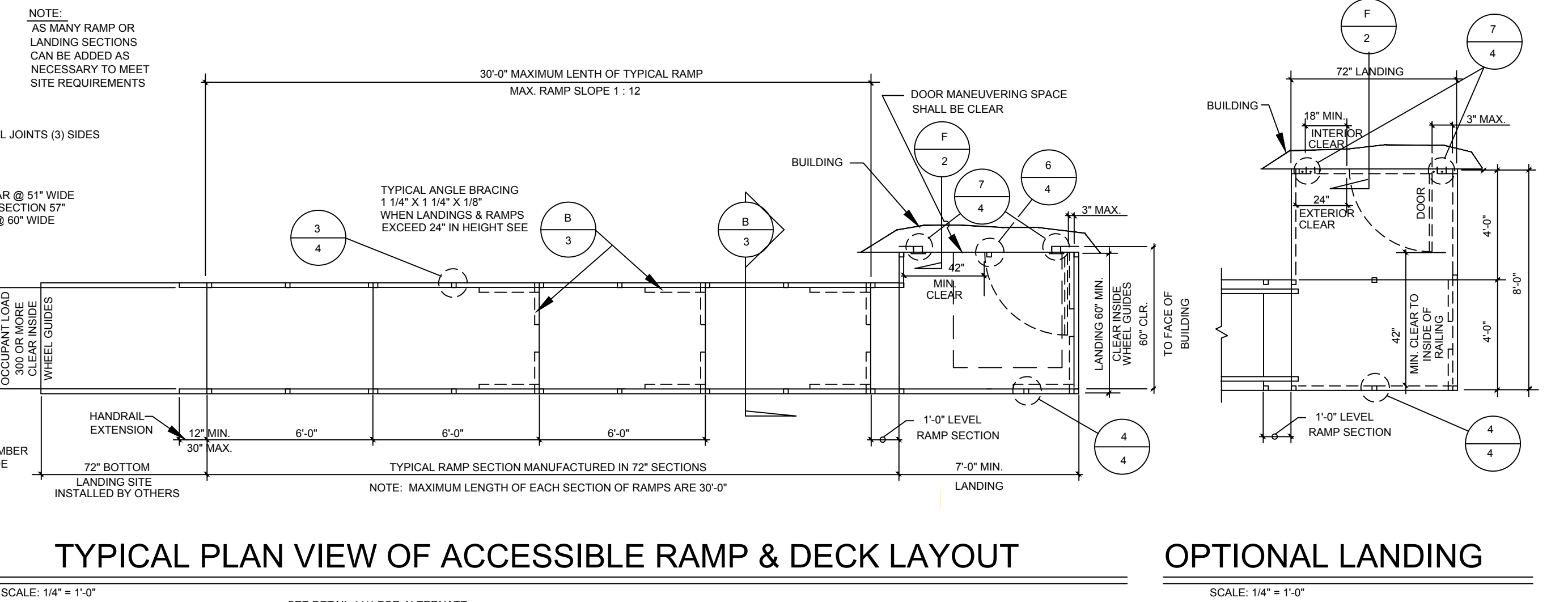

**TYPICAL PLAN VIEW OF ACCESSIBLE RAMP & DECK LAYOUT**

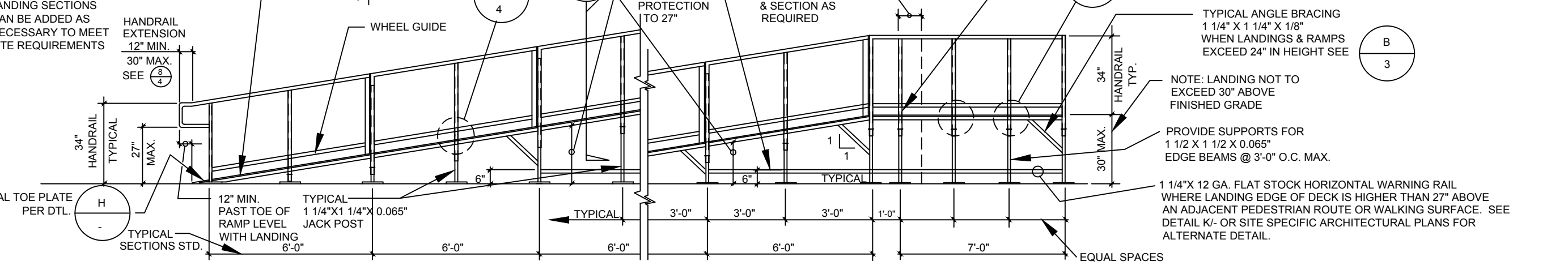

**TYPICAL ELEVATION OF ACCESSIBLE RAMP & DECKING 30" OR LESS**

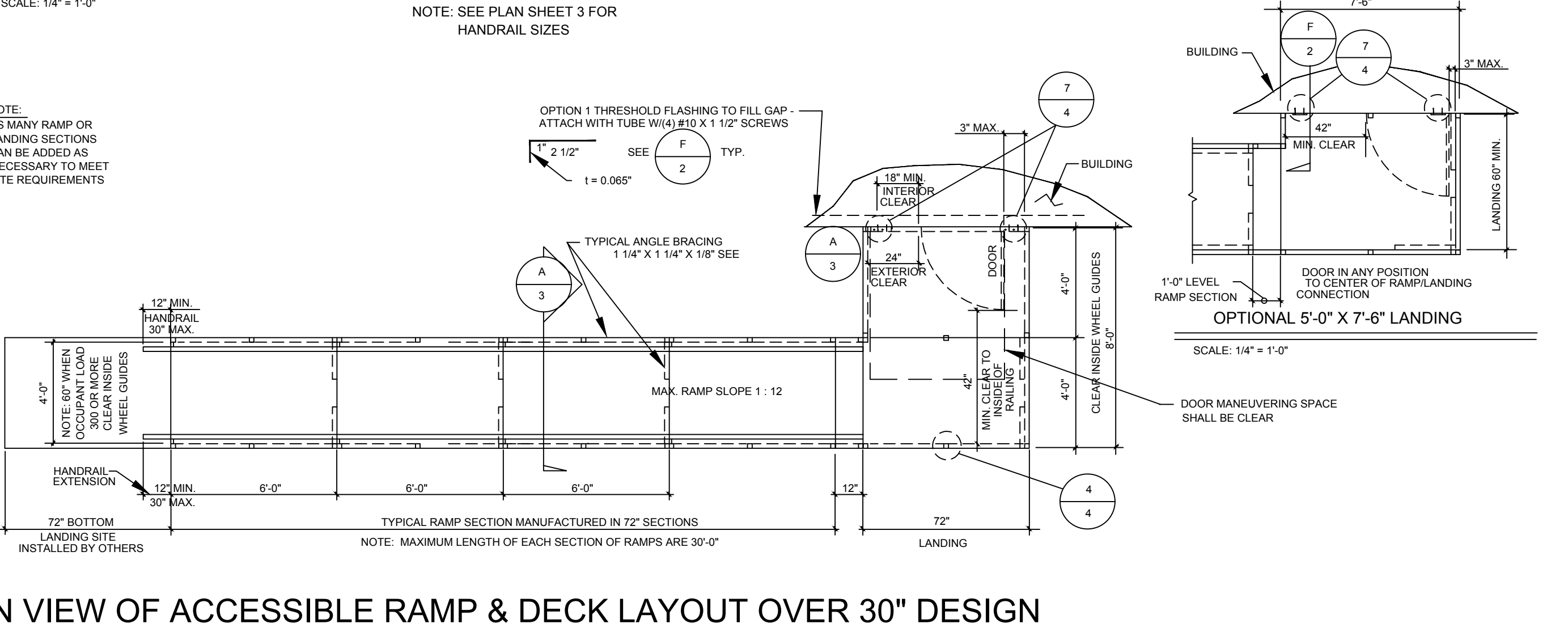

**TYPICAL PLAN VIEW OF ACCESSIBLE RAMP & DECK LAYOUT OVER 30" DESIGN**

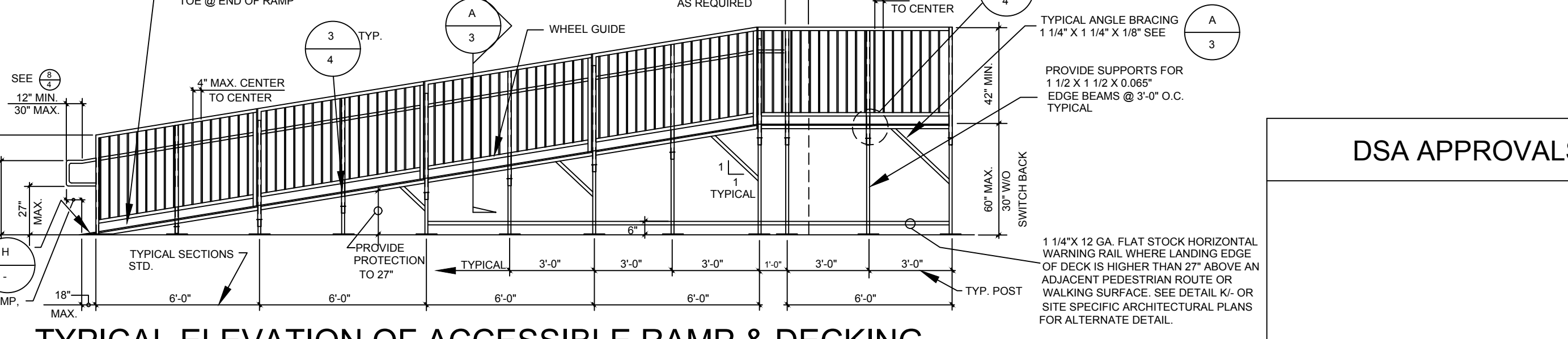

**TYPICAL ELEVATION OF ACCESSIBLE RAMP & DECKING**

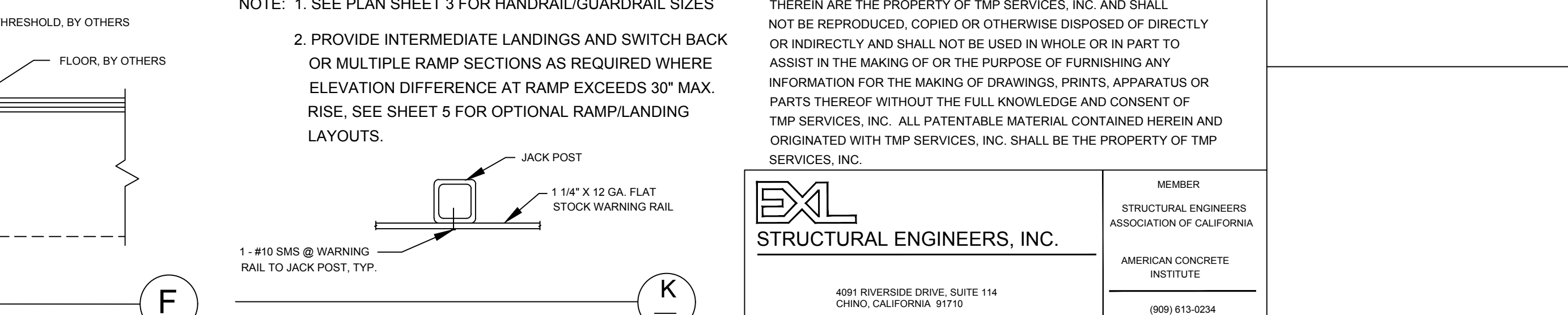

**FILLER DETAIL**

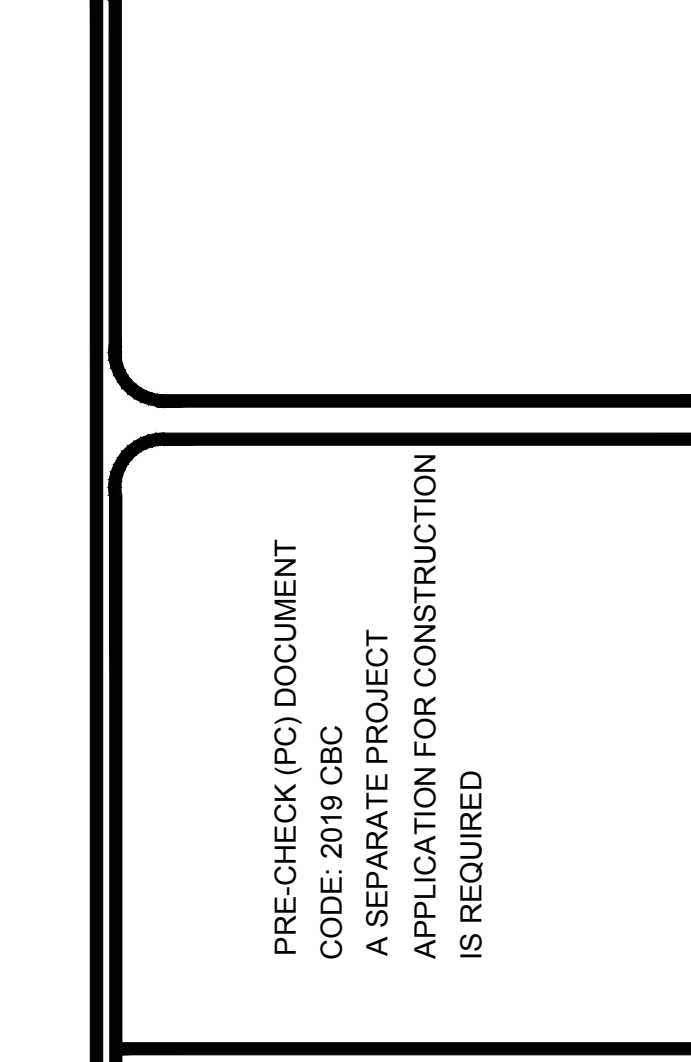

**OPTIONAL LANDING**



**OPTIONAL 5'-0" X 7'-6" LANDING**

PRE-CHECK (PC) DOCUMENT  
 CODE: 2019 CBC  
 A SEPARATE PROJECT APPLICATION FOR CONSTRUCTION IS REQUIRED



DATE SIGNED: January 7, 2021

APPROVED  
 DIV. OF THE STATE ARCHITECT  
 APP: 04-119501 PC  
 REVIEWED FOR  
 SS  FLS  ACS  CG   
 DATE: 02/09/2021

ACCESSIBLE RAMP ELEVATIONS & DETAILS  
 TMP SERVICES  
 2929 KANSAS AVE.  
 RIVERSIDE, CA 92507  
 PHONE: (951)213-3900  
 FAX: (951)213-3997

STATE OF CALIFORNIA  
 PC  
 -2019 CBC

DRAWN  
 CHECKED  
 DATE: 03 FEB 2020  
 SCALE  
 JOB NO.

MEMBER  
 STRUCTURAL ENGINEERS ASSOCIATION OF CALIFORNIA  
 AMERICAN CONCRETE INSTITUTE  
 (909) 613-0234







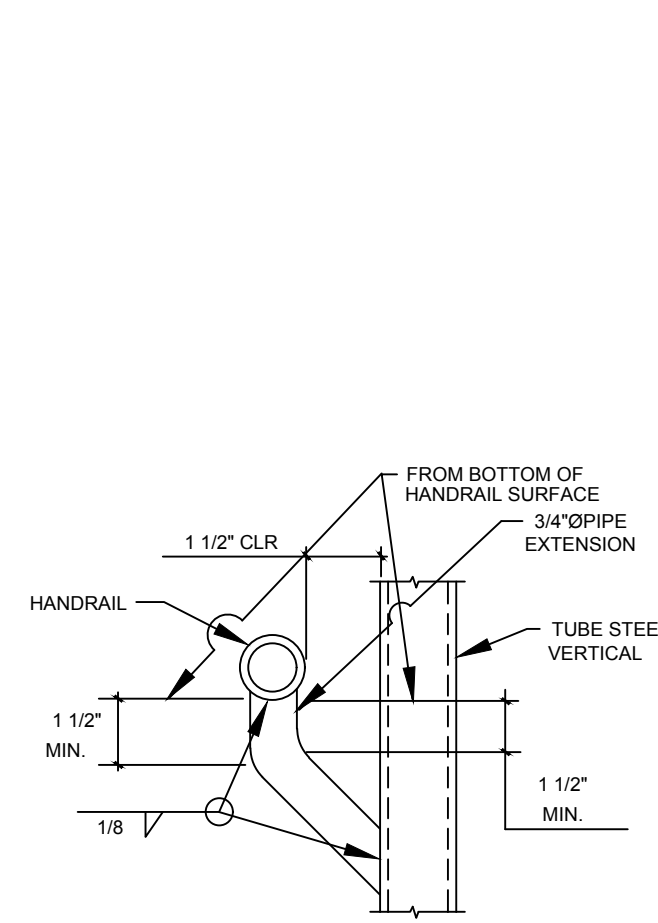

2  
4 TYPICAL HANDRAIL ARMS

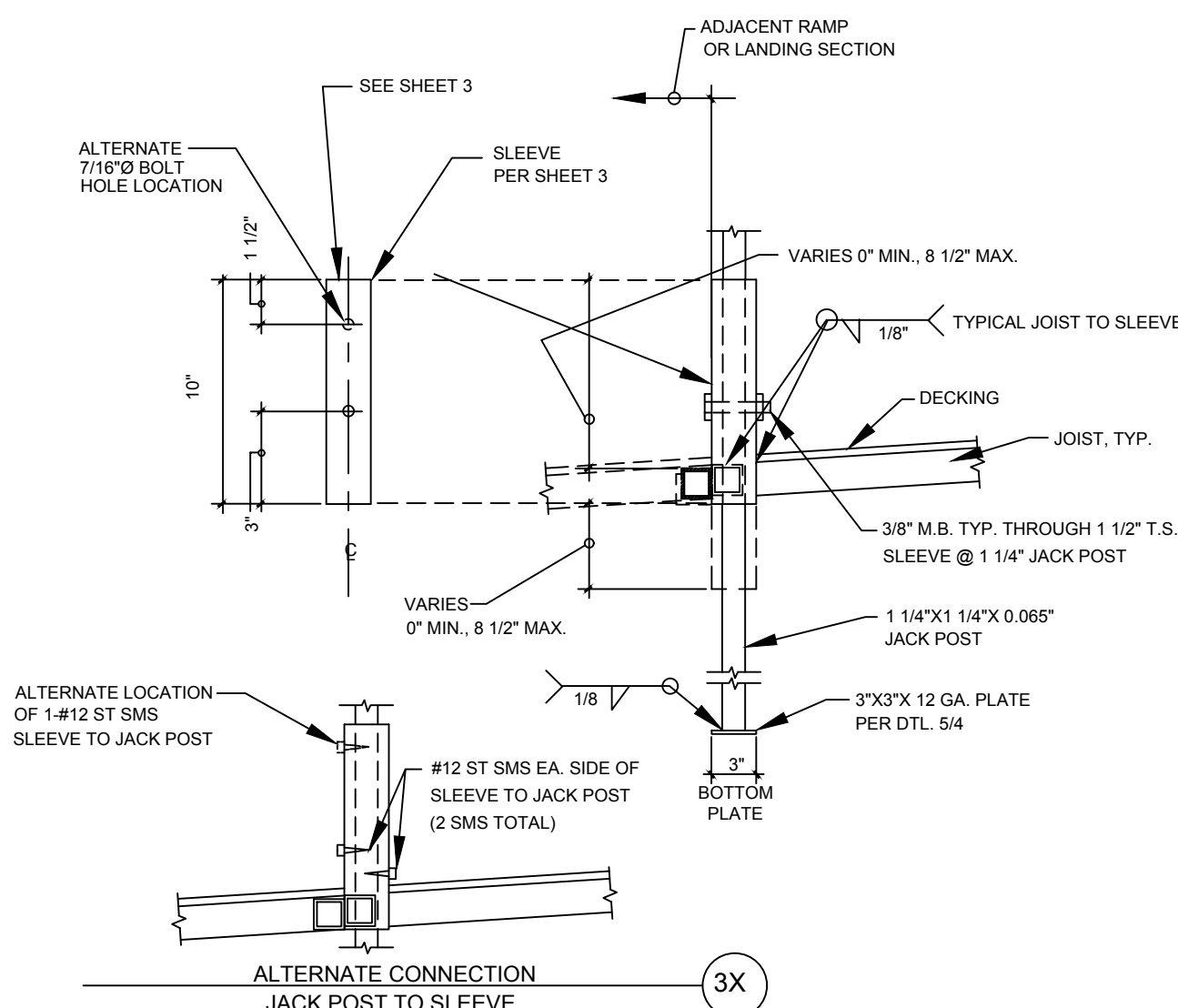

3  
4 RAMP POST SLEEVES 1 1/2" T.S.

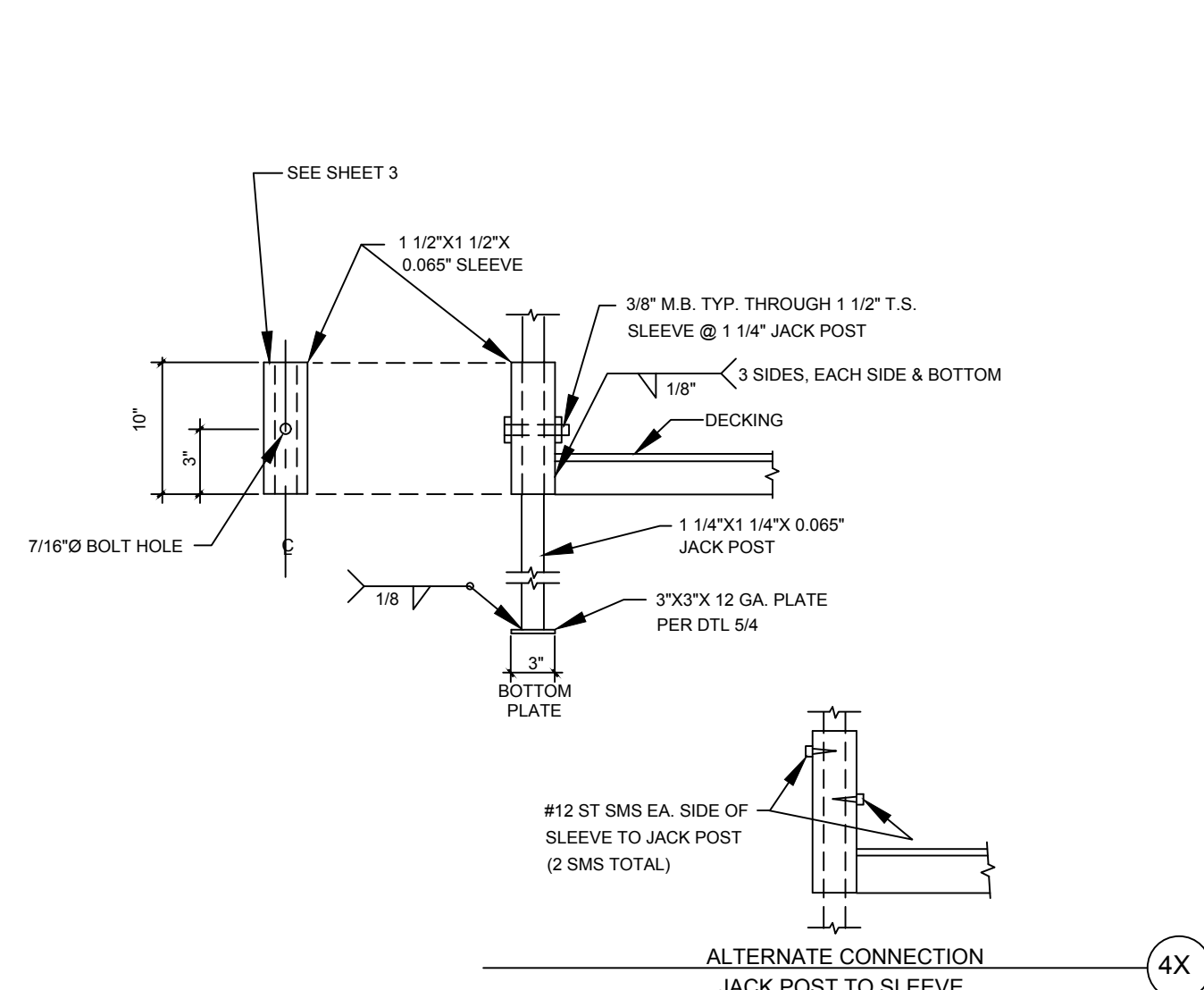

4  
4 LANDING POST SLEEVES 1 1/2" T.S.

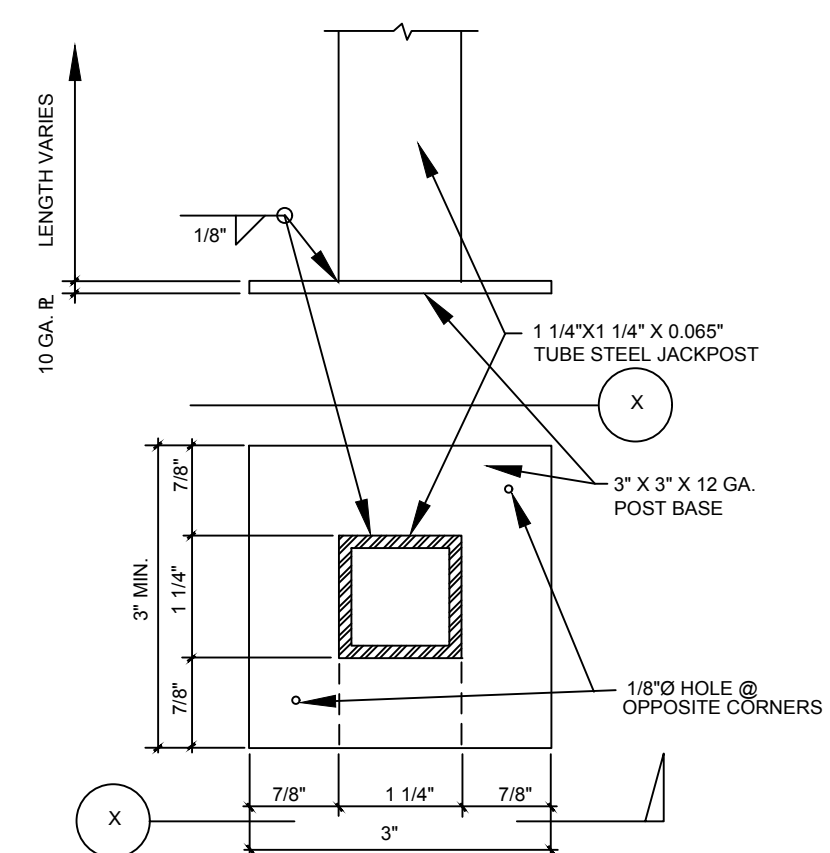

5  
4 POST BASE

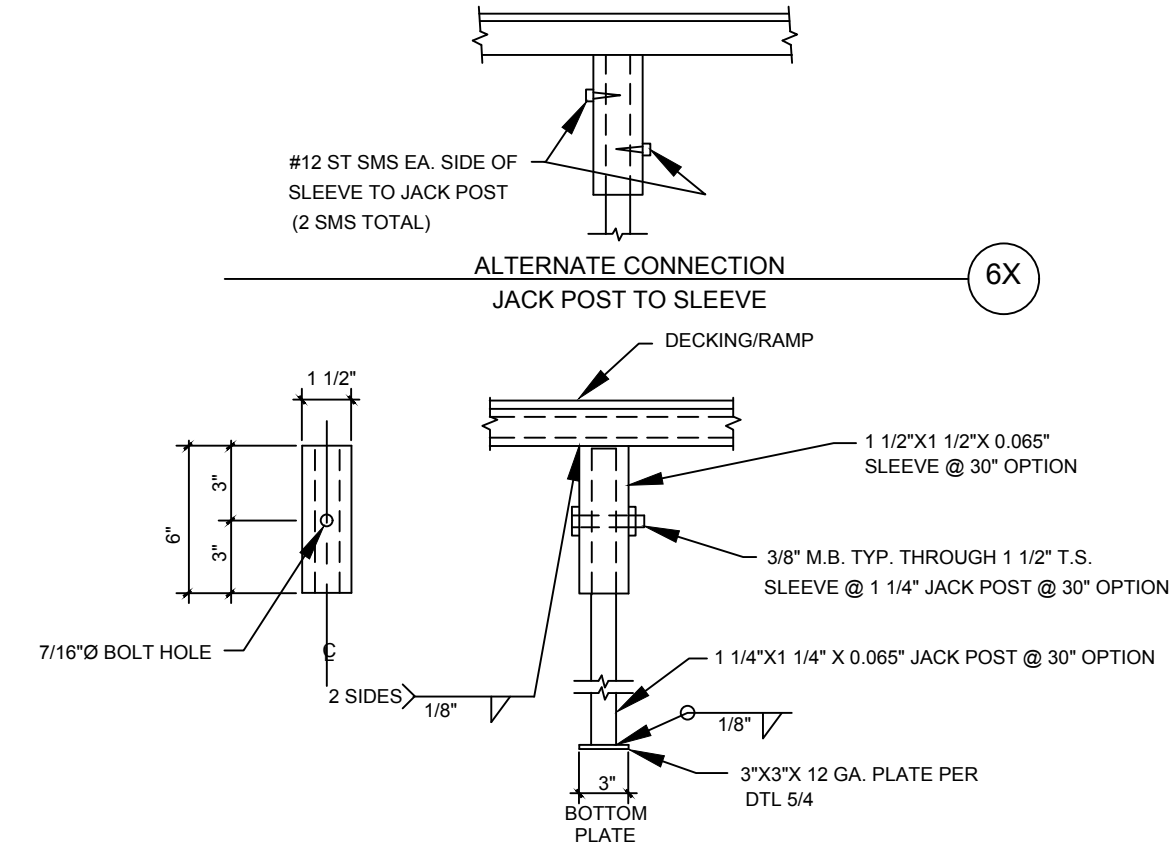

6  
4 MID SPAN POST  
NOTE: USE 2" X 2" X 0.12" SLEEVE AND 1 1/2" X 1 1/2" X 0.065" JACK POST @ ABOVE 30° OPTION

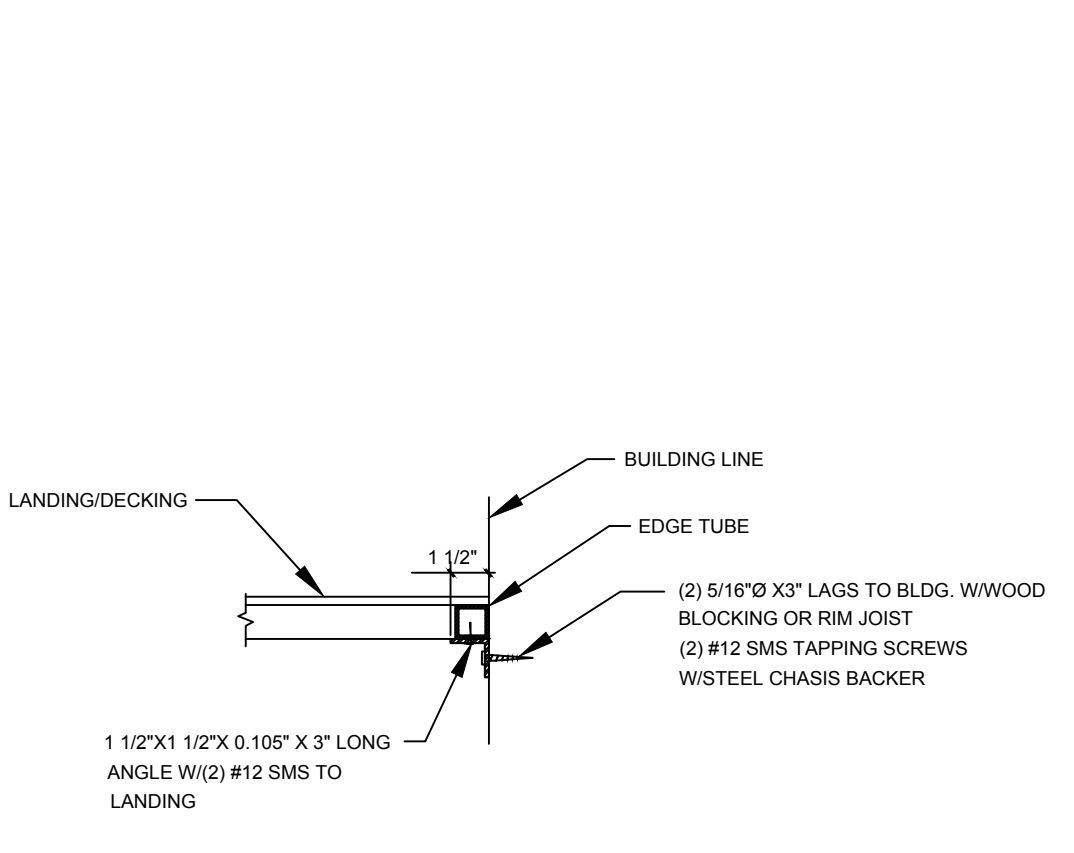

7  
4 LANDING TO BUILDING  
NOTE: DECK SECTIONS ARE FREE STANDING FOR VERTICAL LOADS.

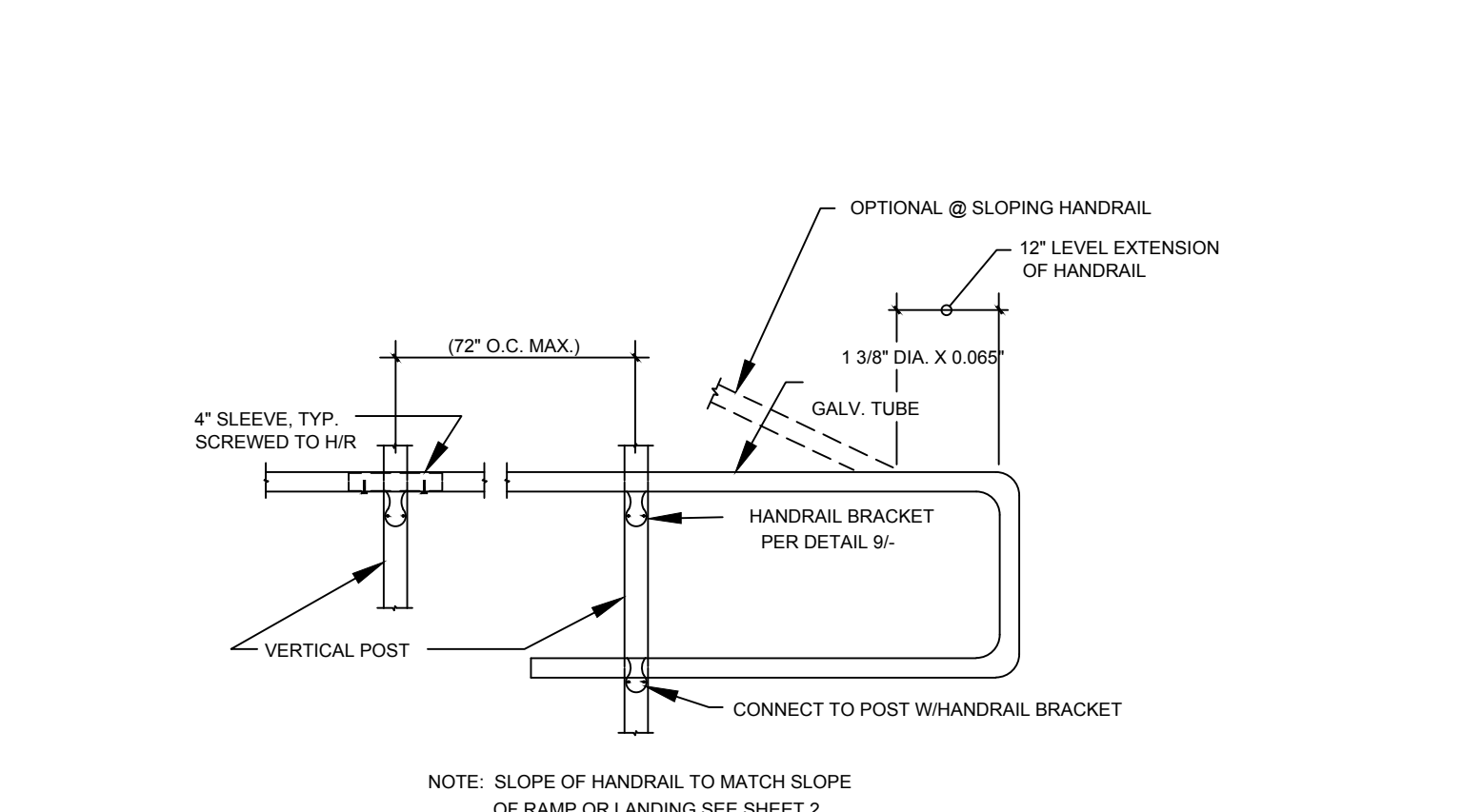

8  
4 OPTIONAL CONNECTION @ HANDRAIL DETAIL  
NOTE: SLOPE OF HANDRAIL TO MATCH SLOPE OF RAMP OR LANDING SEE SHEET 2.

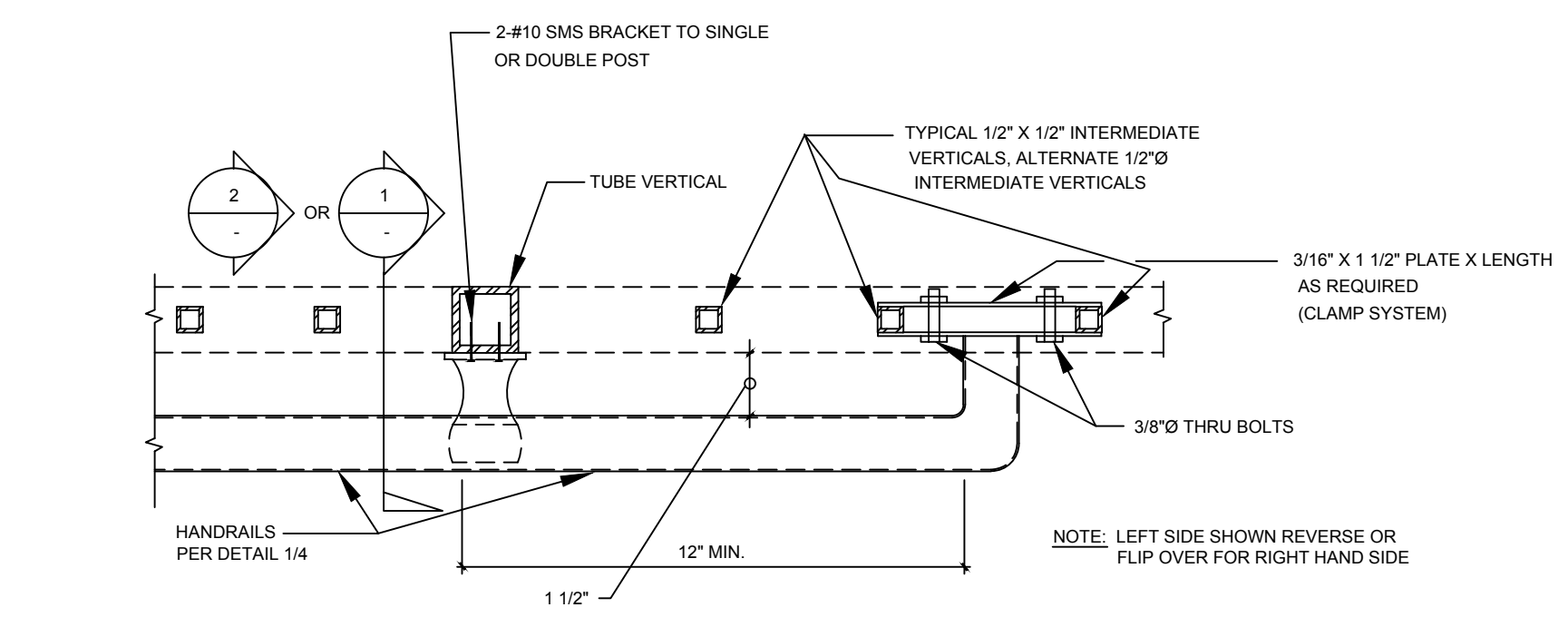

9  
4 OPTIONAL HANDRAIL DETAIL @ TOP OF STAIRS OR RAMPS

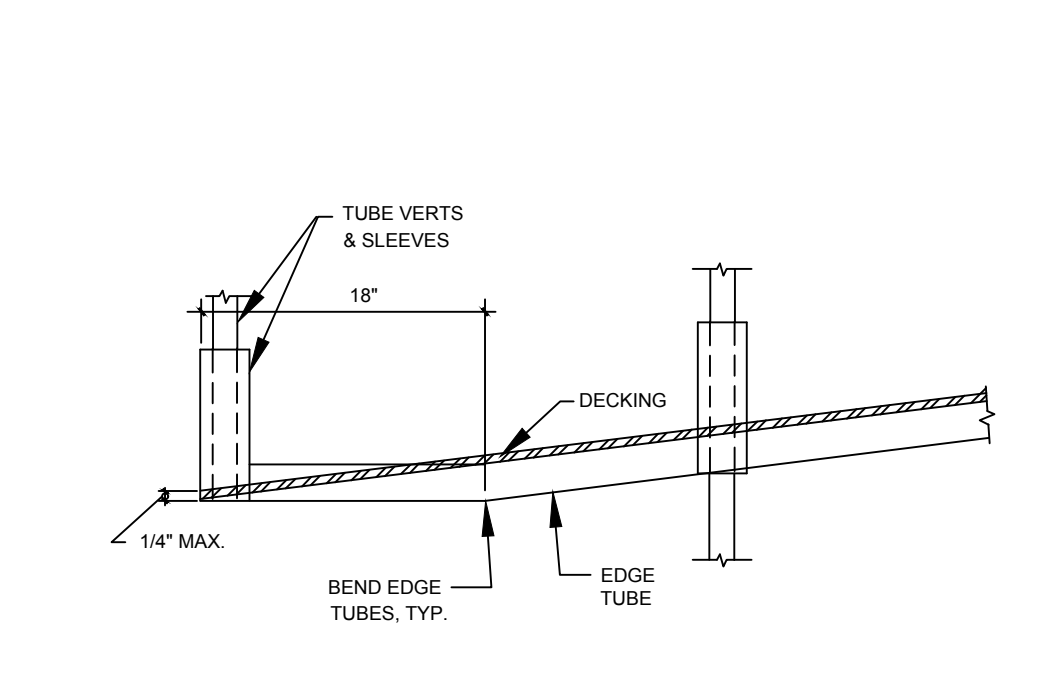

10  
4 TOE @ END OF RAMP  
NO SCALE

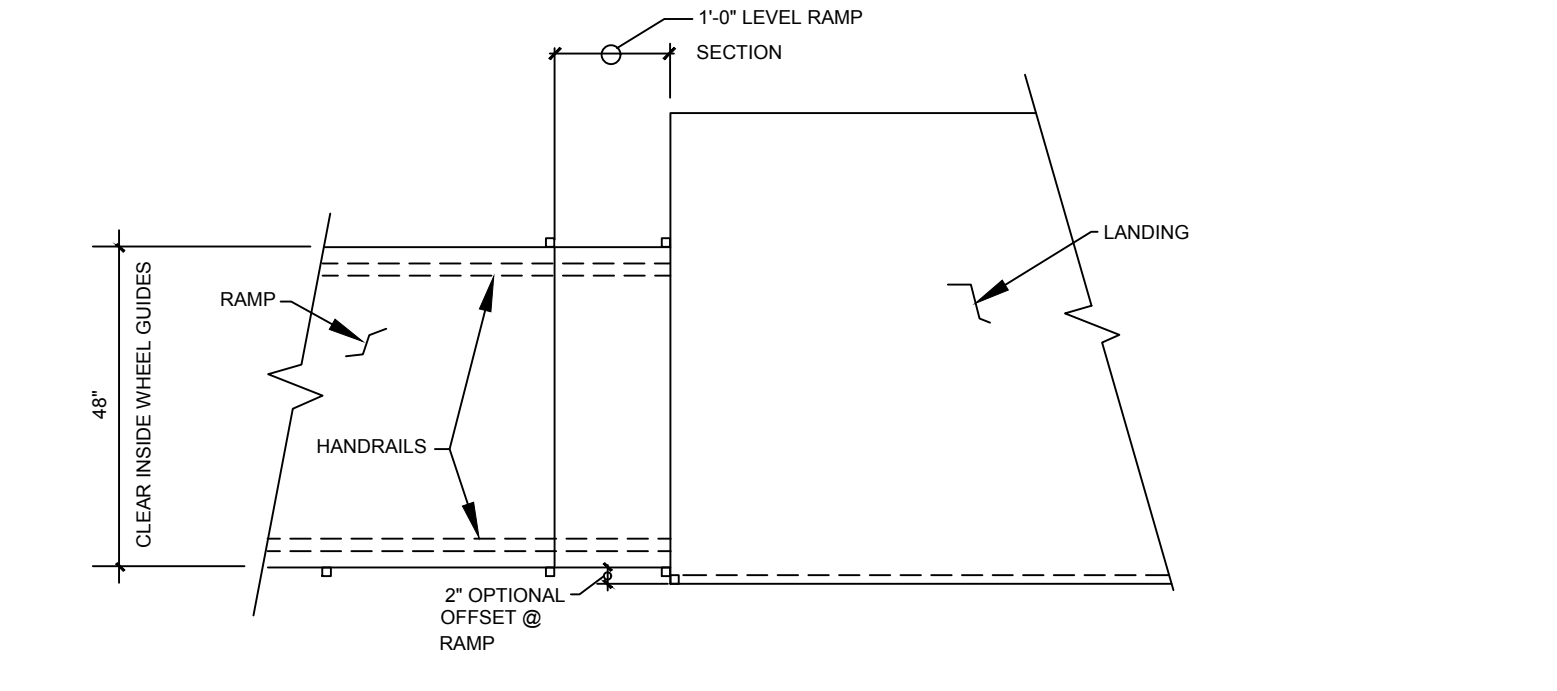

11  
4 NO SCALE

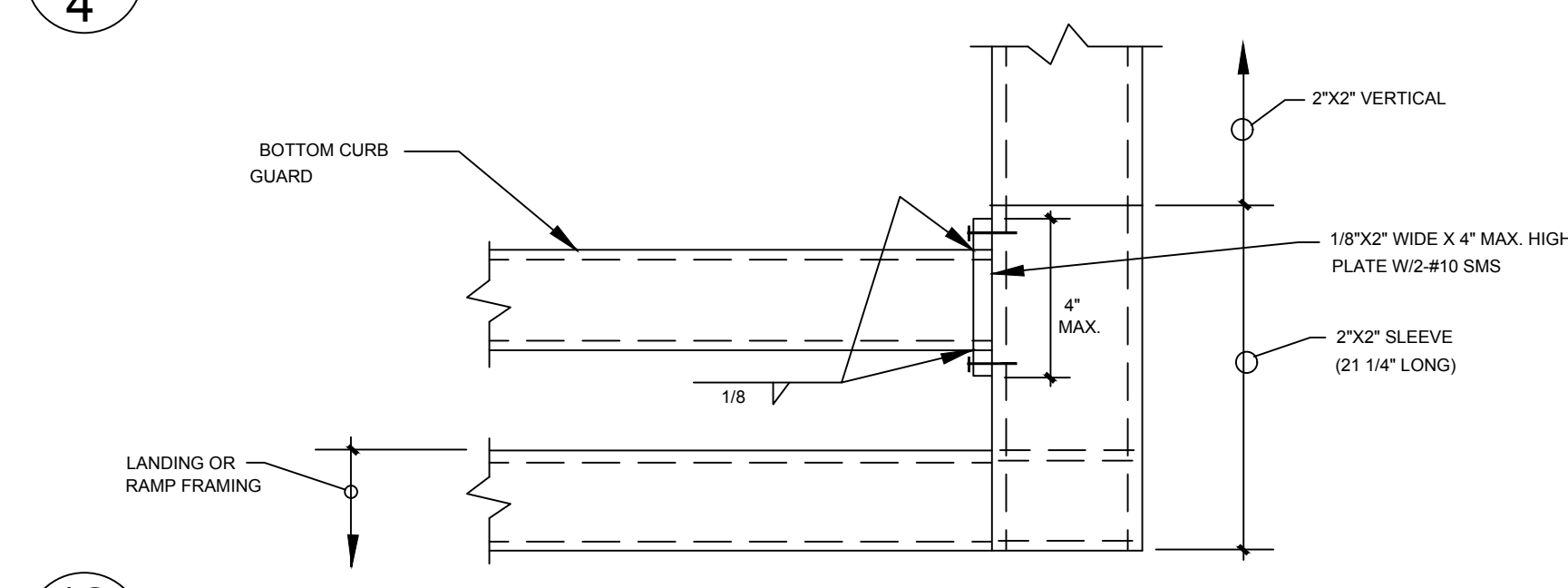

12  
4

NOTES:  
 CODES:  
 2019 CALIFORNIA BUILDING CODE (CBC)  
 DESIGN LOADS:  
 LIVE LOAD: 100 PSF  
 WIND LOAD: SEE SHEET 1  
 SEISMIC: SEE SHEET 1  
 HANDRAIL & GUARD RAIL LOADS:  
 50MF  
 200M POINT LOAD  
 MATERIAL SPECIFICATIONS:  
 STEEL: ALL TUBE STEEL ASTM A-1099 CS TYPE A OR B (F<sub>y</sub> = 40 KSI)  
 ALL SHEET, ANGLES, PLATE ETC. TO BE A1015SS GRADE 40  
 ALL STEEL TO BE COATED WITH A RUST INHIBITIVE COATING  
 PLYWOOD OPTION: APA RATED STRUCT I EXTERIOR PLYWOOD  
 BOLTS: ASTM A307 COMMON BOLTS HOT DIPPED GALVANIZED W/ STAINLESS STEEL WASHERS  
 WELDS: ALL WELDING SHALL CONFORM TO "AMERICAN WELDING SOCIETY D-1-3-2008 FOR SHEET STEEL. ELECTRODES SHALL BE E70XX.  
 GENERAL NOTES:  
 1) RAMP HAVING SLOPES STEEPER THAN 1 VERTICAL TO 20 HORIZONTAL SHALL HAVE LANDINGS AT TOP AND BOTTOM AND AT LEAST ONE INTERMEDIATE LANDING SHALL BE PROVIDED FOR EACH 30° OF RISE. PER CBC 11B-405.7.  
 2) LOCATION OF LANDINGS.  
 LANDINGS SHALL BE PROVIDED AT TOP AND BOTTOM OF EACH RAMP. INTERMEDIATE LANDINGS SHALL BE PROVIDED AT INTERVALS NOT EXCEEDING 30 INCHES OF VERTICAL RISE AND AT EACH CHANGE OF DIRECTION. LANDINGS ARE NOT CONSIDERED IN DETERMINING THE MAXIMUM HORIZONTAL DISTANCE OF EACH RAMP.  
 NOTE: EXAMPLES OF RAMP DIMENSIONS ARE:  

SLOPE	MAX. RISE (INCHES)	MAX. HORIZONTAL PROJECTION
1:12	30	30'-0"
1:16	30	40'-0"
1:20	30	50'-0"
1:15	30	37'-6"

 2. SIZE OF TOP LANDINGS. TOP LANDINGS SHALL NOT BE LESS THAN 60 INCHES WIDE AND SHALL HAVE A LENGTH OF NOT LESS THAN 60 INCHES IN THE DIRECTION OF RAMP RUN. PER CBC 11B-405.7.2 AND 3.  
 3) DOORS IN ANY POSITION SHALL NOT REDUCE THE MINIMUM DIMENSION OF THE LANDING TO LESS THAN 42" AND SHALL NOT REDUCE THE REQUIRED WIDTH BY MORE THAN 3" WHEN FULLY OPENED. CBC 11B-405.7.5.  
 4) RAMP SHALL BE CONSTRUCTED AS REQUIRED FOR STAIRWAYS.  
 5) THE SURFACE OF RAMPS SHALL BE ROUGHED OR SHALL BE OF SLIP-RESISTANT MATERIAL, TYP. FOR LANDINGS & STAIRS.  
 6) RAMP REQUIREMENTS SHALL BE PER CBC 11B-405.  
 7) RAMP AND STAIRWAYS USED AS EXIT SHALL CONFORM TO CBC SEC. 1009 SEC. 1010, CHAPTER 11B AND 11B-405.5.  
 8) HANDRAILS AND GUARDRAILS SHALL CONFORM TO CBC 11B-405.8 (RAMP), AND 11B-504 (STAIRS).  
 9) RAMP SHALL CONFORM TO CBC 11B-405.  
 10) STRIKE EDGE EXTENSION THE WIDTH OF THE LANDING SHALL EXTEND 24" PAST THE STRIKE EDGE OF ANY DOOR OR GATE FOR EXTERIOR RAMPS AND 18" PAST THE STRIKE EDGE FOR INTERIOR RAMPS.  
 11) LANDING WIDTH. AT BOTTOM AND INTERMEDIATE LANDINGS, THE WIDTH SHALL BE AT LEAST THE SAME AS REQUIRED FOR RAMPS, CBC 11B-405.7.4.  
 12) THE WIDTH OF RAMPS SHALL BE AS REQUIRED PER STAIRWAYS AND EXITS, CBC 11B-405.5.  
 13) SLOPE RAMPS AND LANDINGS AS REQUIRED TO PREVENT ACCUMULATION OF WATER ON WALKING SURFACES.  
 14) ALL WORK SHALL CONFORM TO TITLE 24 CALIFORNIA CODE OF REGULATIONS (CCR).  
 15) CHANGES TO APPROVED DRAWINGS AND SPECIFICATIONS SHALL BE MADE BY AN ADDENDUM OR A CONSTRUCTION CHANGE DOCUMENT (CCD) APPROVED BY THE DIVISION OF THE STATE ARCHITECT AS REQUIRED BY SECTION 4-338, PART 1 TITLE 24, CCR.  
 16) A PROJECT INSPECTOR EMPLOYED BY THE DISTRICT (OWNER) AND APPROVED BY THE DIVISION OF STATE ARCHITECT SHALL PROVIDE CONTINUOUS INSPECTION OF THE WORK. THE DUTIES OF THE INSPECTOR ARE DEFINED IN SECTION 4-342 PART 1 TITLE 24 CCR.  
 IN PLANT: SHOP WELDING INSPECTION AND MATERIAL VERIFICATION  
 SITE CONSTRUCTION: CLASS 4

PRE-CHECK (PC) DOCUMENT  
 CODE: 2019 CBC  
 A SEPARATE PROJECT APPLICATION FOR CONSTRUCTION IS REQUIRED



January 7, 2021  
 DATE SIGNED

APPROVED  
 DIV. OF THE STATE ARCHITECT  
 APP: 04-119501 PC  
 REVIEWED FOR  
 SS  FLS  ACS  CG   
 DATE: 02/09/2021

DETAILS AND NOTES  
 TMP SERVICES  
 2929 KANSAS AVE  
 RIVERSIDE, CA 92507  
 PHONE: (951)213-3900  
 FAX: (951)213-3997

SITE: \_\_\_\_\_  
 STATE OF CALIFORNIA  
 -2019 CBC  
 PC

DSA APPROVALS

PROPRIETARY DESIGN: THIS DRAWING AND THE MATERIAL CONTAINED THEREIN ARE THE PROPERTY OF TMP SERVICES, INC. AND SHALL NOT BE REPRODUCED, COPIED OR OTHERWISE DISPOSED OF DIRECTLY OR INDIRECTLY AND SHALL NOT BE USED IN WHOLE OR IN PART TO ASSIST IN THE MAKING OF OR THE PURPOSE OF FURNISHING ANY INFORMATION FOR THE MAKING OF DRAWINGS, PRINTS, APPARATUS OR PARTS THEREOF WITHOUT THE FULL KNOWLEDGE AND CONSENT OF TMP SERVICES, INC. ALL PATENTABLE MATERIAL CONTAINED HEREIN AND ORIGINATED WITH TMP SERVICES, INC. SHALL BE THE PROPERTY OF TMP SERVICES, INC.

**EXL**  
 STRUCTURAL ENGINEERS, INC.  
 4091 RIVERSIDE DRIVE, SUITE 114  
 CHINO, CALIFORNIA 91710  
 (951) 613-0234

MEMBER  
 STRUCTURAL ENGINEERS ASSOCIATION OF CALIFORNIA  
 AMERICAN CONCRETE INSTITUTE  
 (809) 613-0234

DRAWN \_\_\_\_\_  
 CHECKED \_\_\_\_\_  
 DATE: 03 FEB 2020  
 SCALE \_\_\_\_\_  
 JOB NO. \_\_\_\_\_

4  
 4 OF 16 SHEETS

TMP DSG-RAMP LANDING STEEL SHEET 4/09



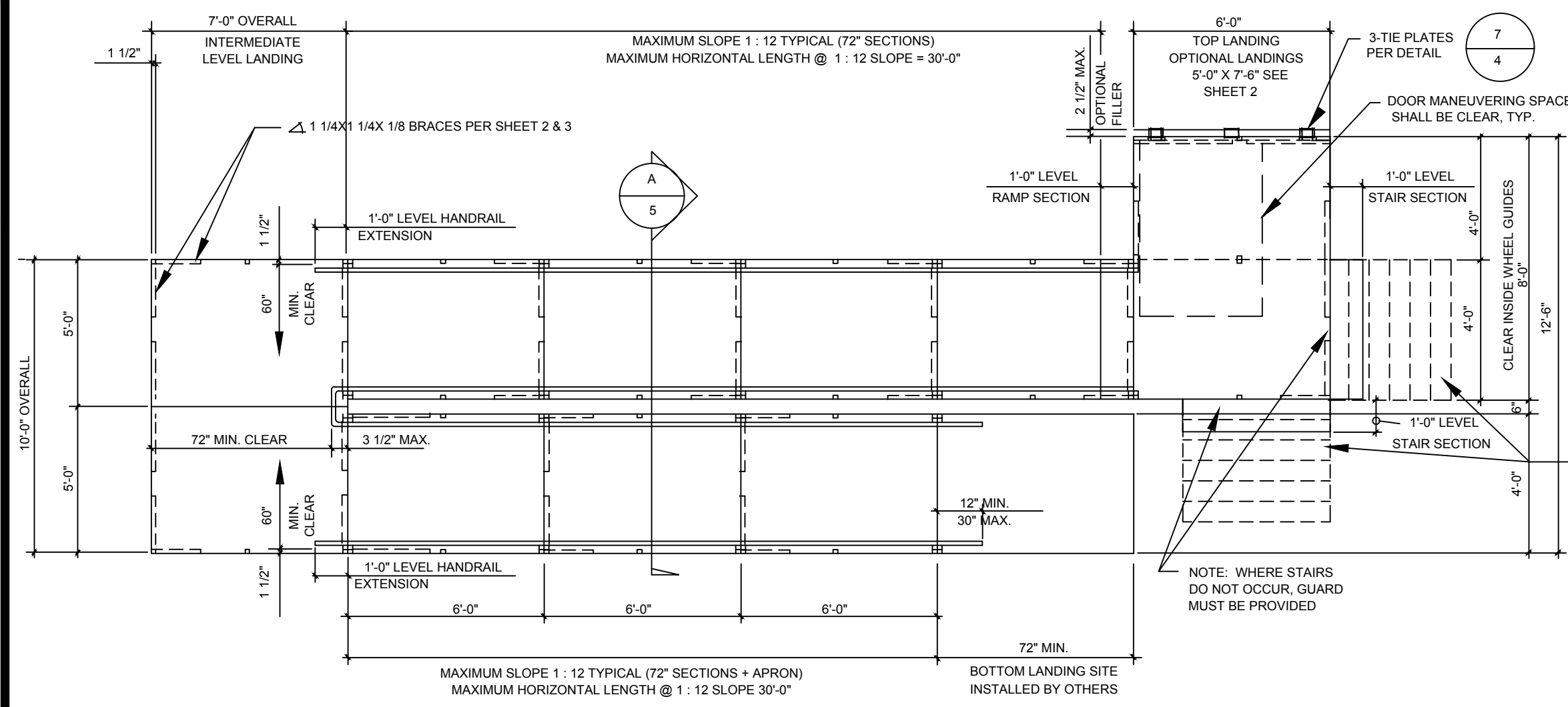

**TYPICAL PLAN VIEW OF ACCESSIBLE RAMP WITH SWITCH-BACK & PLATFORMS**

SCALE: 1/4" = 1'-0"

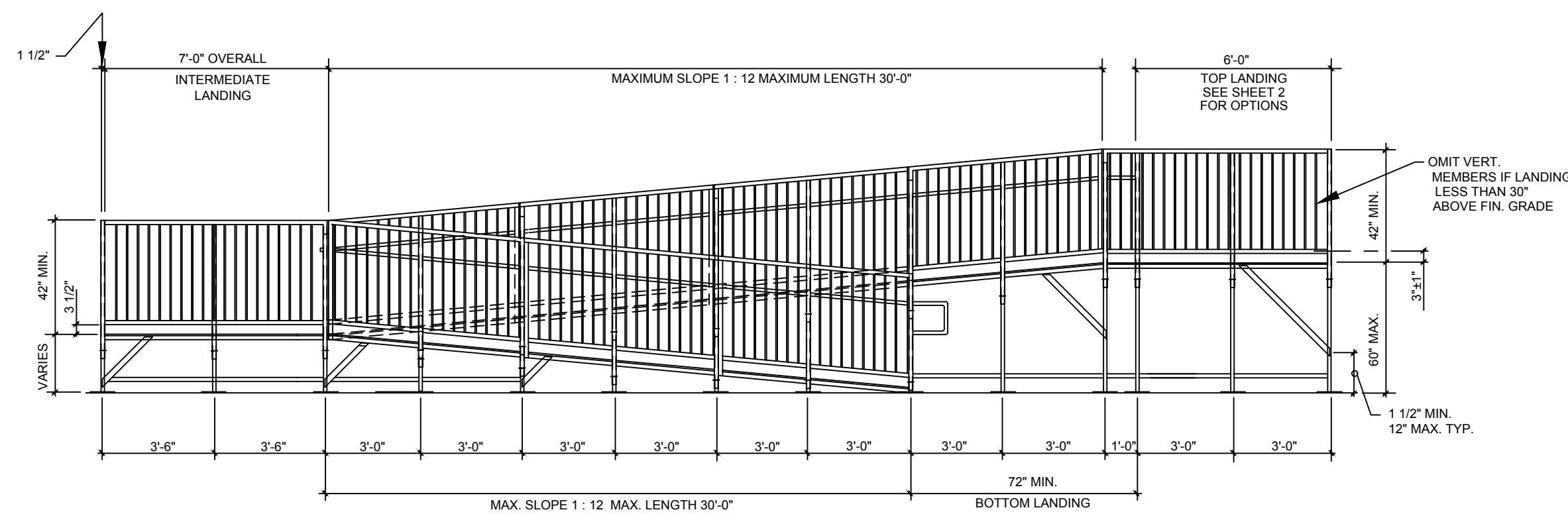

**TYPICAL ELEVATION OF ACCESSIBLE RAMP W/SWITCH-BACK RAMP**

SCALE: 1/4" = 1'-0"

NOTE: SEE SHEET 3 FOR HANDRAIL/GUARDRAIL SIZES

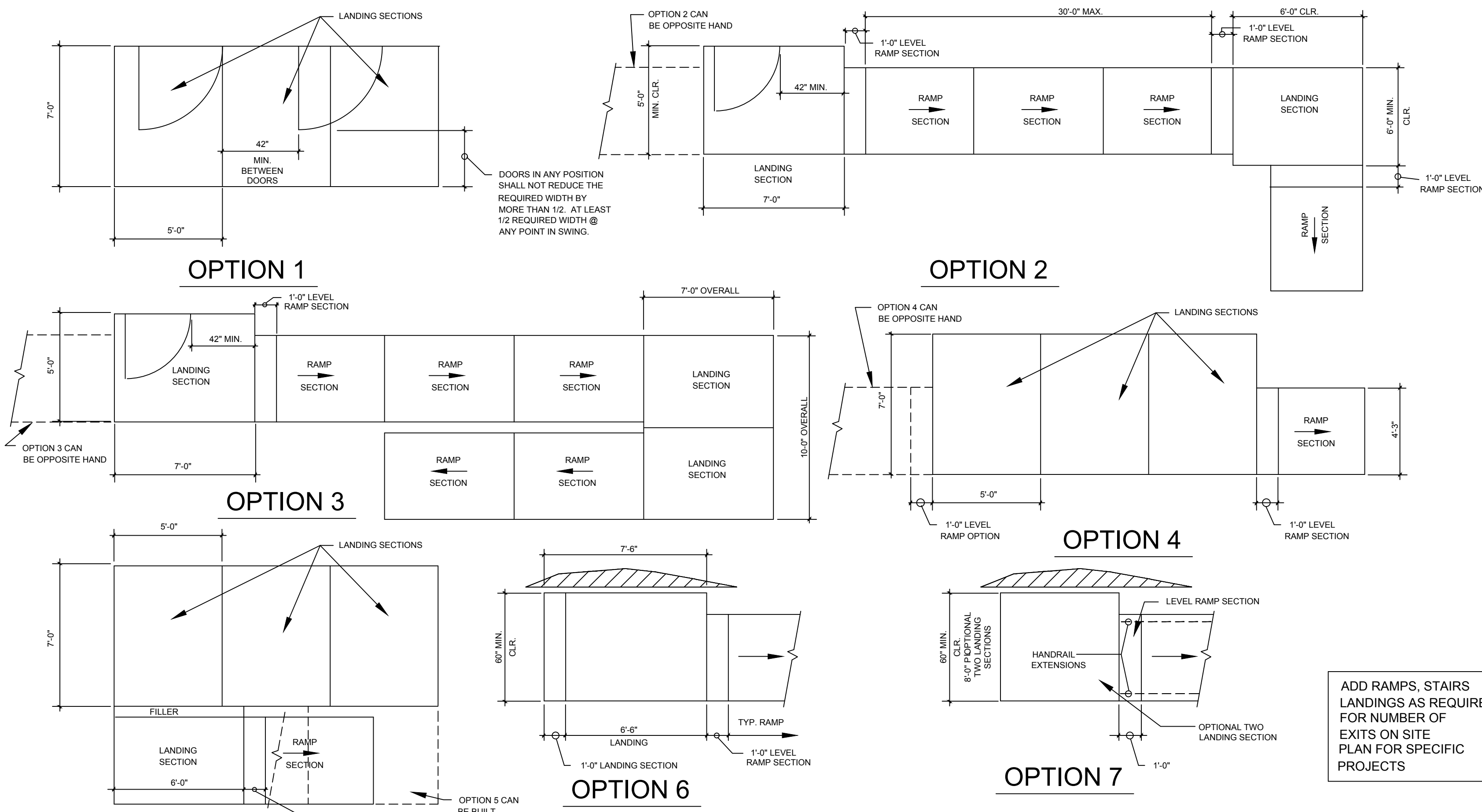

**MULTIPLE LANDINGS AND RAMPS**

NOTE: SEE SHEET 2 FOR LANDING AND RAMP DETAILS, SEE SHEET 6 FOR TYPICAL STAIRS

ADD RAMPS, STAIRS, LANDINGS AS REQUIRED FOR NUMBER OF EXITS ON SITE. PLAN FOR SPECIFIC PROJECTS

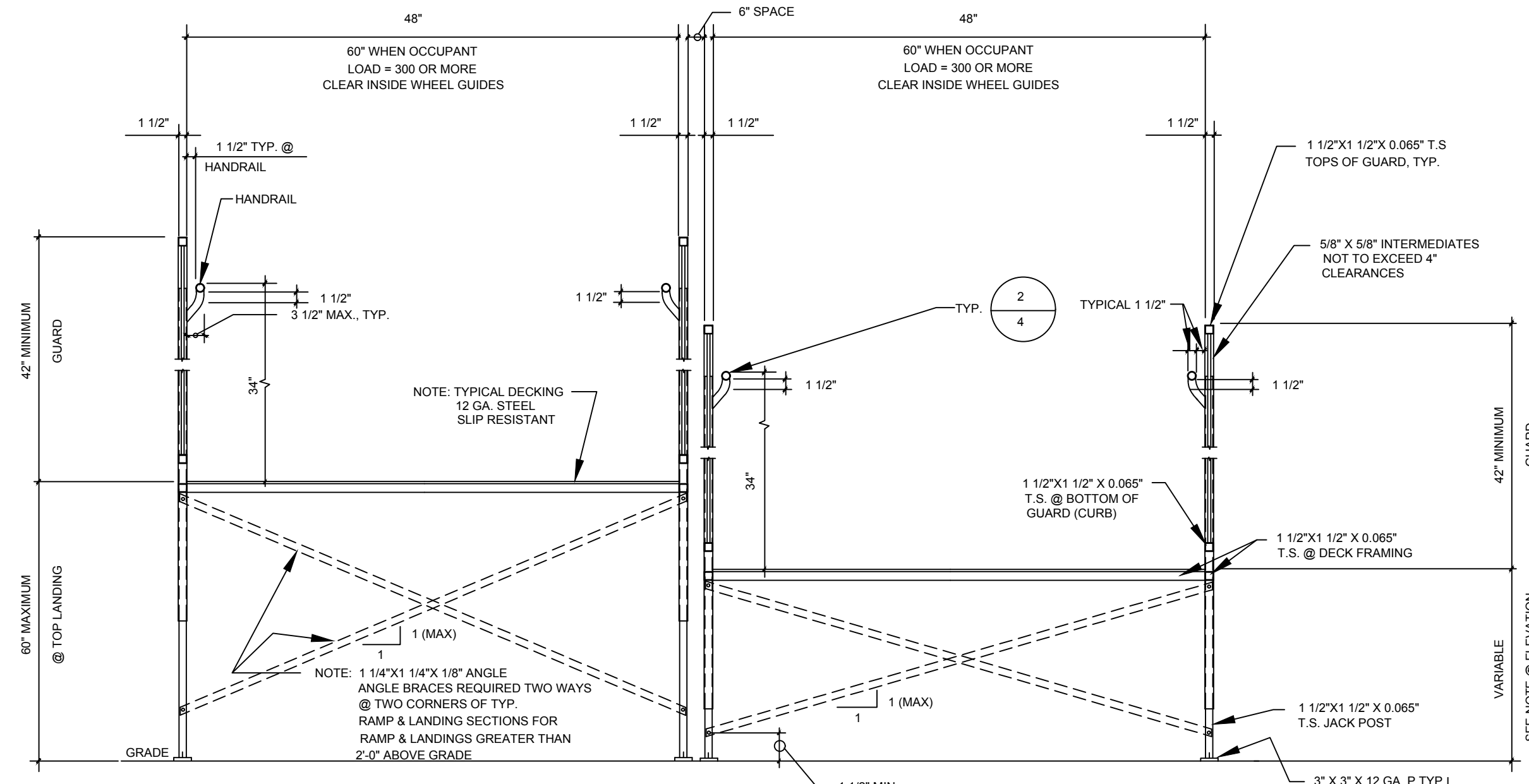

**TYPICAL CROSS SECTIONS**

SCALE: 1/4" = 1'-0"

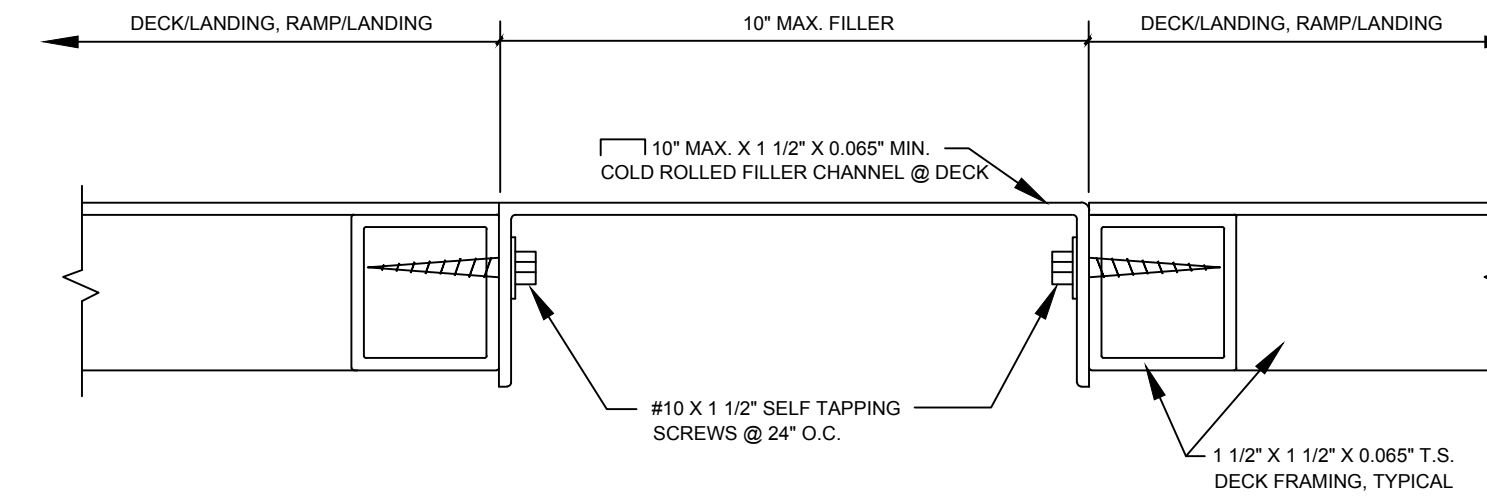

**TYPICAL DECK CROSS SECTION**

SCALE: 1/2" = 1'-0"

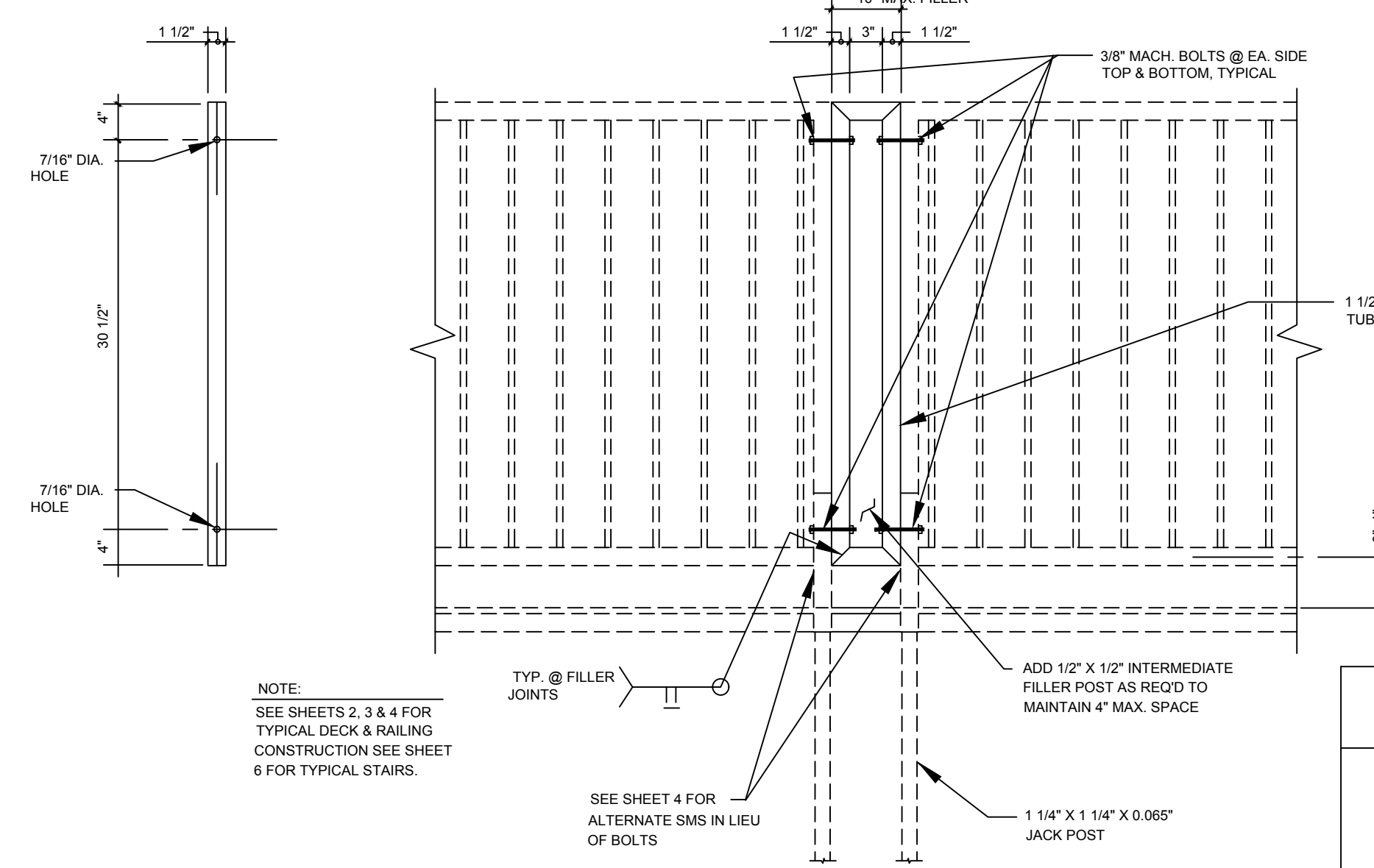

**TYPICAL GUARDRAIL FILLER**

SCALE: 3/4" = 1'-0"

PROPRIETARY DESIGN: THIS DRAWING AND THE MATERIAL CONTAINED THEREIN ARE THE PROPERTY OF TMP SERVICES, INC. AND SHALL NOT BE REPRODUCED, COPIED OR OTHERWISE DISPOSED OF DIRECTLY OR INDIRECTLY AND SHALL NOT BE USED IN WHOLE OR IN PART TO ASSIST IN THE MAKING OF OR THE PURPOSE OF FURNISHING ANY INFORMATION FOR THE MAKING OF DRAWINGS, PRINTS, APPARATUS OR PARTS THEREOF WITHOUT THE FULL KNOWLEDGE AND CONSENT OF TMP SERVICES, INC. ALL PATENTABLE MATERIAL CONTAINED HEREIN AND ORIGINATED WITH TMP SERVICES, INC. SHALL BE THE PROPERTY OF TMP SERVICES, INC.

**EXL**  
STRUCTURAL ENGINEERS, INC.

4091 RIVERSIDE DRIVE, SUITE 114  
CHINO, CALIFORNIA 91710

MEMBER  
STRUCTURAL ENGINEERS  
ASSOCIATION OF CALIFORNIA  
AMERICAN CONCRETE  
INSTITUTE  
(909) 613-0234

PRE-CHECK (PC) DOCUMENT  
CODE: 2019 CBC  
A SEPARATE PROJECT  
APPLICATION FOR CONSTRUCTION  
IS REQUIRED



DATE SIGNED: January 7, 2021

APPROVED  
DIV. OF THE STATE ARCHITECT  
APP: 04-119501 PC  
REVIEWED FOR  
SS  FLS  ACS  CG   
DATE: 02/09/2021

ACCESSIBLE RAMP  
SWITCHBACK DETAILS  
TMP SERVICES  
2929 KANSAS AVE  
RIVERSIDE, CA 92507  
PHONE: (951)213-3900  
FAX: (951)213-3997

SITE: \_\_\_\_\_  
STATE OF CALIFORNIA  
PC  
-2019 CBC

DSA APPROVALS  
DRAWN  
CHECKED  
DATE  
03 FEB 2020  
SCALE  
JOB NO.  
5  
5 OF 16 SHEETS



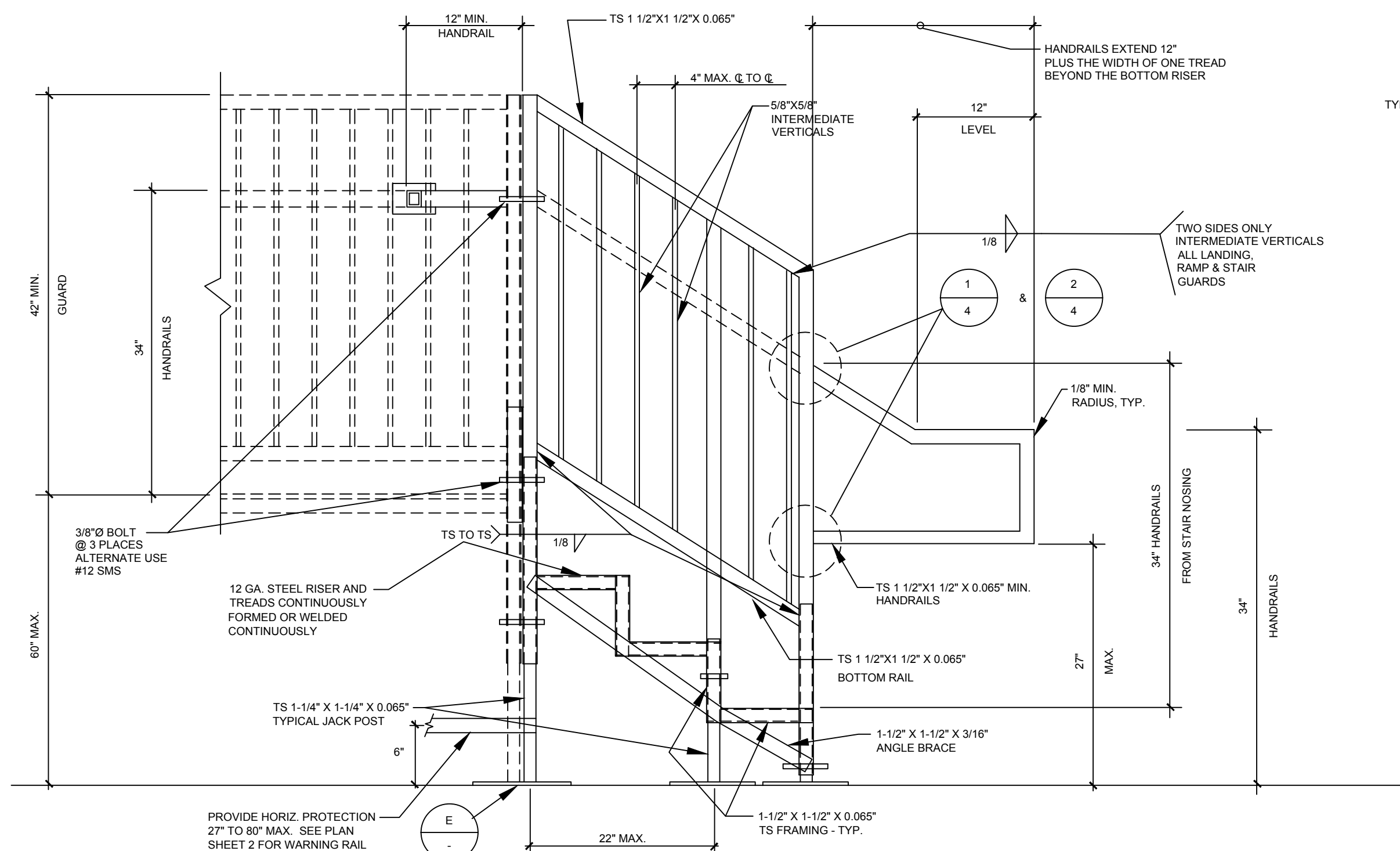

**SIDE VIEW**

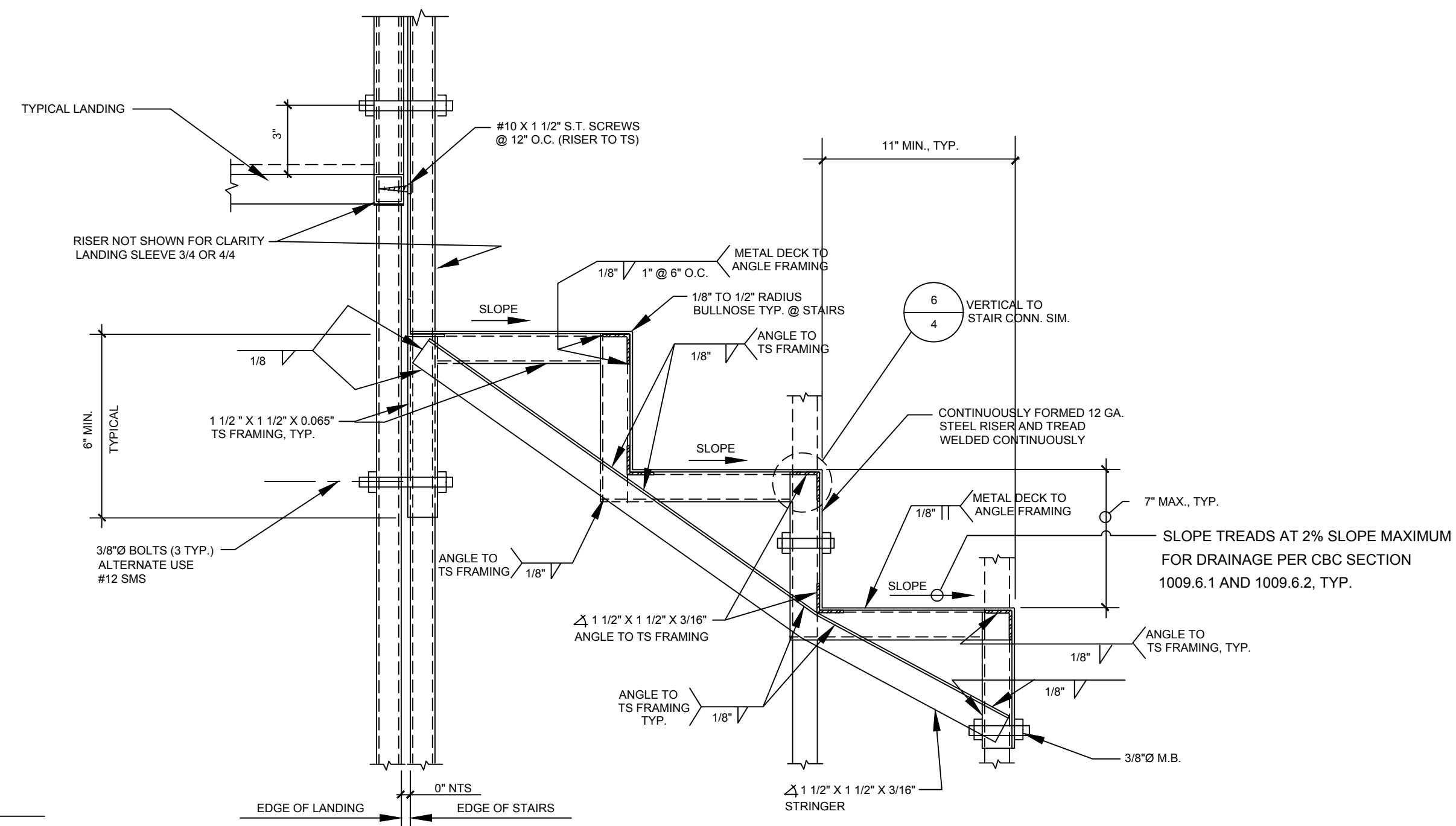

**SECTION**

NOTE: PICKETS & 42" HIGH GUARD REQUIRED FOR THRESHOLD HEIGHTS GREATER THAN 30" ABOVE FINISH GRADE. FOR THRESHOLD HEIGHTS LESS THAN 30" ABOVE FINISH GRADE, PICKETS CAN BE OMITTED & HANDRAIL WILL ACT AS GUARD.

A

B

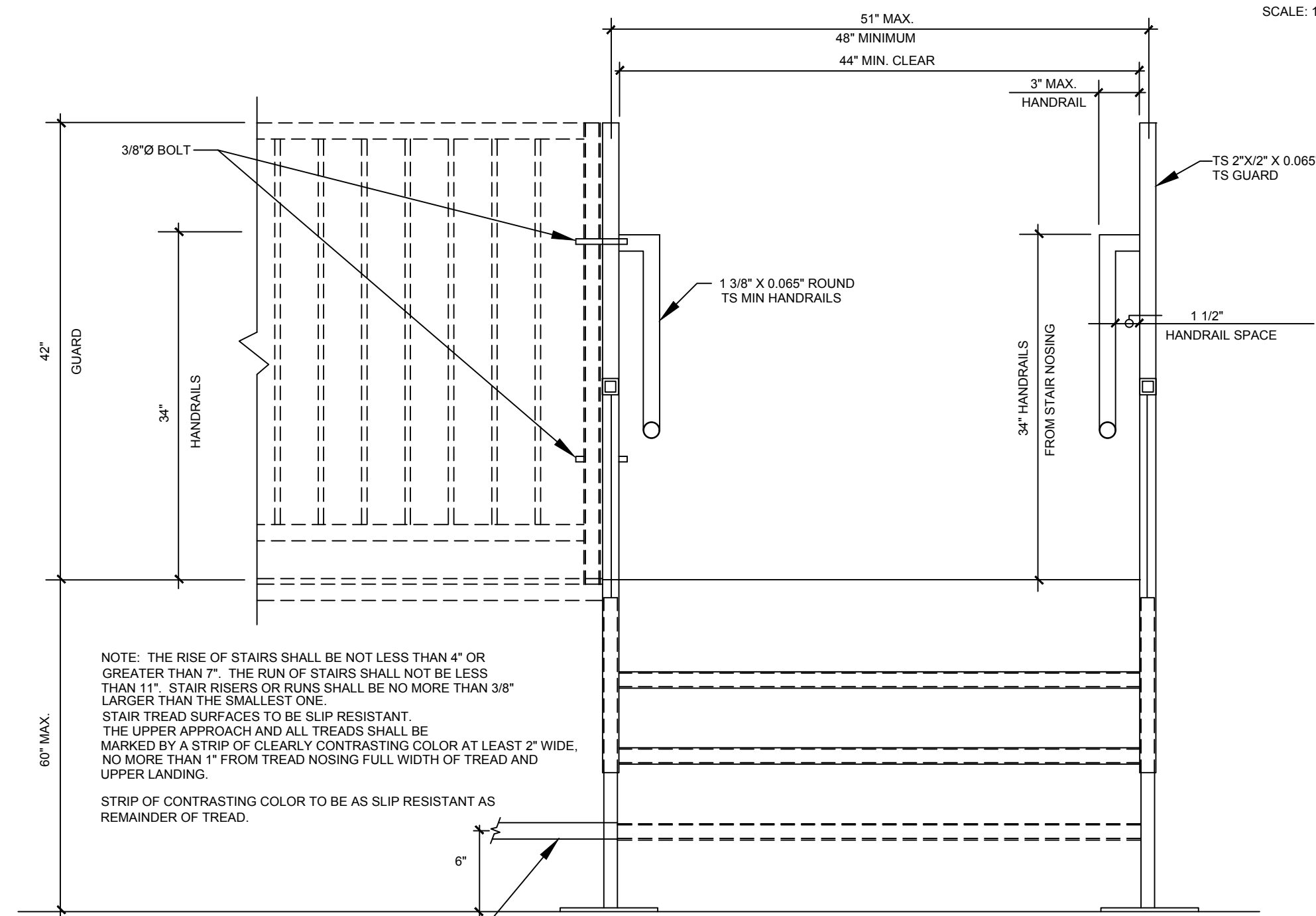

**FRONT VIEW**

C

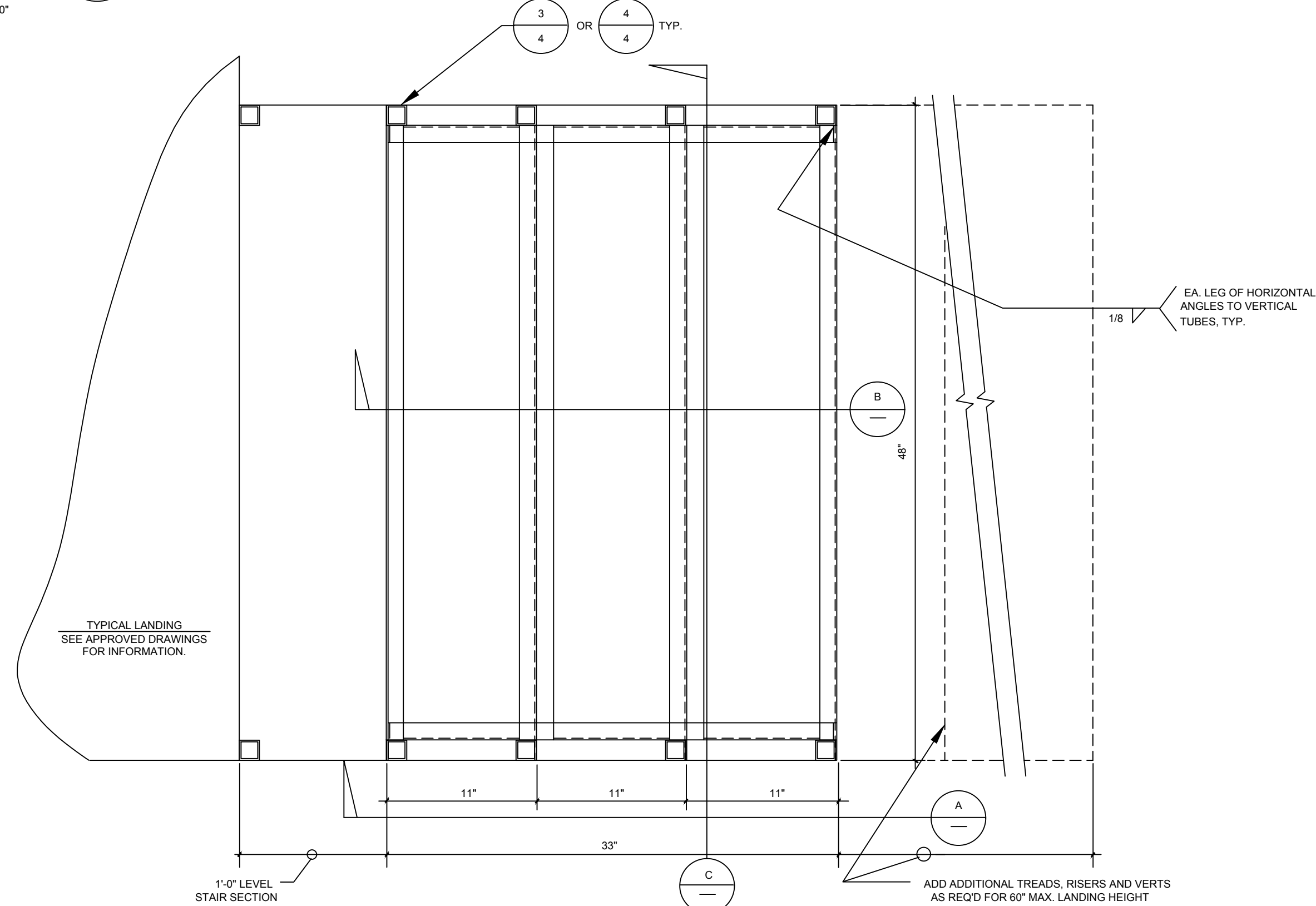

**PLAN VIEW**

D

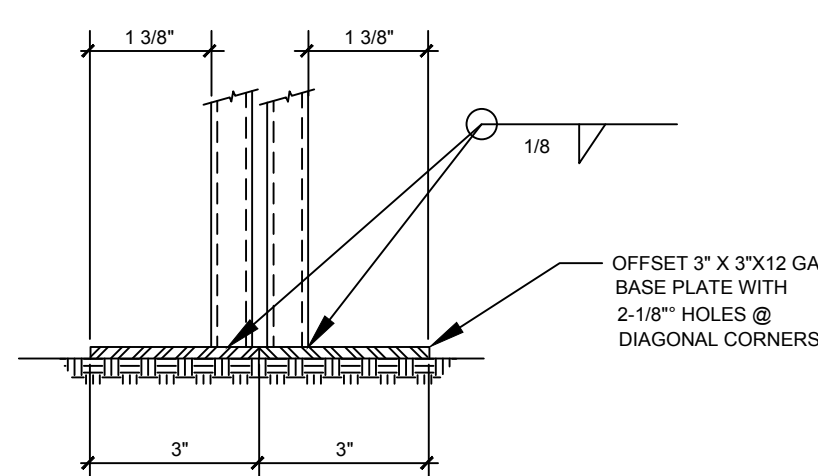

E

PROPRIETARY DESIGN: THIS DRAWING AND THE MATERIAL CONTAINED THEREIN ARE THE PROPERTY OF TMP SERVICES, INC. AND SHALL NOT BE REPRODUCED, COPIED OR OTHERWISE DISPOSED OF DIRECTLY OR INDIRECTLY AND SHALL NOT BE USED IN WHOLE OR IN PART TO ASSIST IN THE MAKING OF OR THE PURPOSE OF FURNISHING ANY INFORMATION FOR THE MAKING OF DRAWINGS, PRINTS, APPARATUS OR PARTS THEREOF WITHOUT THE FULL KNOWLEDGE AND CONSENT OF TMP SERVICES, INC. ALL PATENTABLE MATERIAL CONTAINED HEREIN AND ORIGINATED WITH TMP SERVICES, INC. SHALL BE THE PROPERTY OF TMP SERVICES, INC.

**EXL**  
STRUCTURAL ENGINEERS, INC.

4091 RIVERSIDE DRIVE, SUITE 114  
CHINO, CALIFORNIA 91710

MEMBER  
STRUCTURAL ENGINEERS  
ASSOCIATION OF CALIFORNIA  
AMERICAN CONCRETE  
INSTITUTE  
(909) 613-0234

DSA APPROVALS

SITE:

DRAWN

CHECKED

DATE

03 FEB 2020

SCALE

JOB NO.

6

6 OF 16 SHEETS

PRE-CHECK (PC) DOCUMENT  
CODE: 2019 CBC  
A SEPARATE PROJECT  
APPLICATION FOR CONSTRUCTION  
IS REQUIRED



January 7, 2021

DATE SIGNED

APPROVED  
DIV. OF THE STATE ARCHITECT  
APP: 04-119501 PC  
REVIEWED FOR  
SS  FLS  ACS  CG   
DATE: 02/09/2021

STAIRS OPTIONAL

TMP SERVICES  
2929 KANSAS AVE  
RIVERSIDE, CA 92507  
PHONE: (951)213-3900  
FAX: (951)213-3997

STATE OF CALIFORNIA  
PC

-2019 CBC

TMP DSA RAMP & LANDING STEEL SHEET 6 DWG



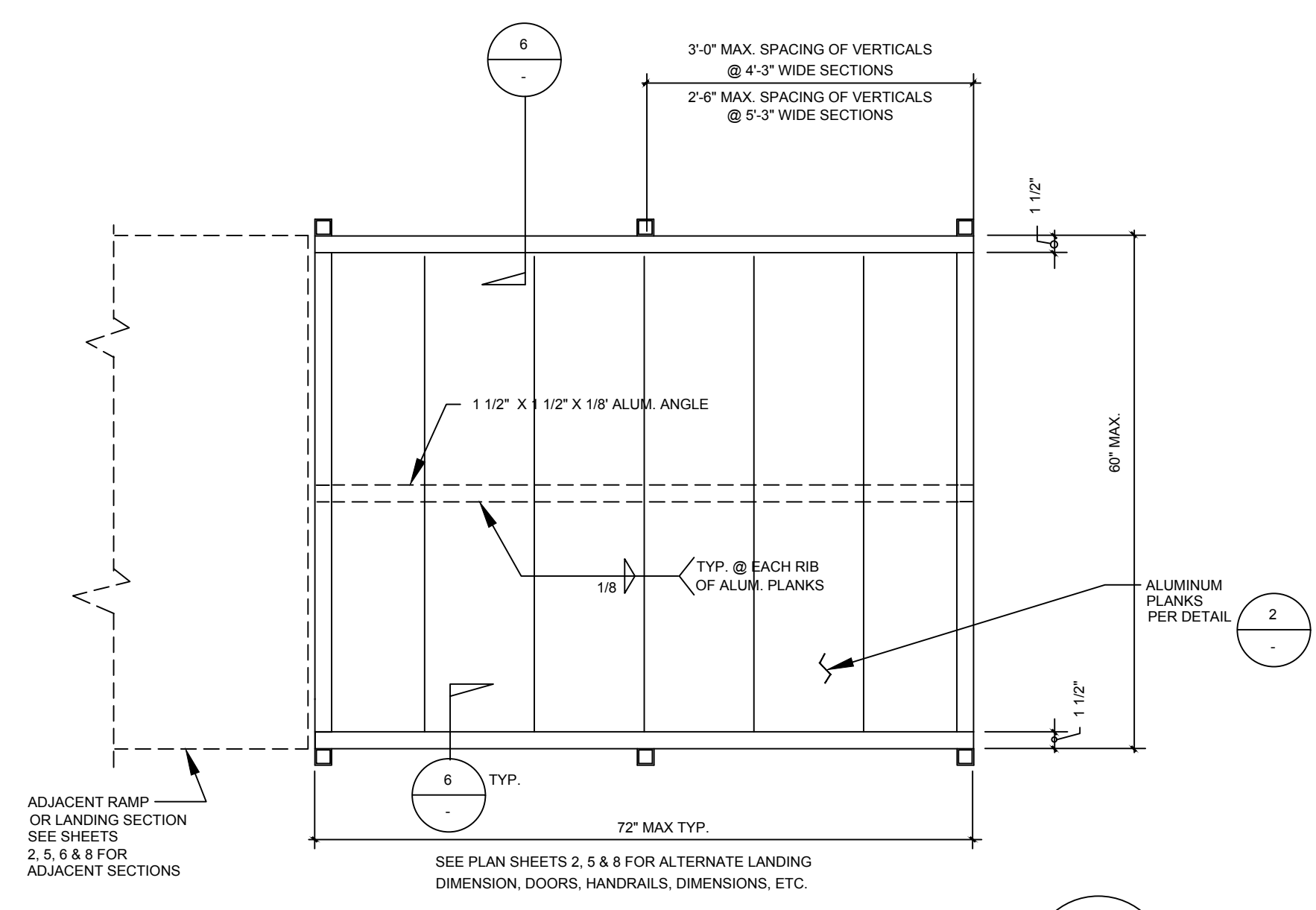

**LANDING OR RAMP SECTION** 1B

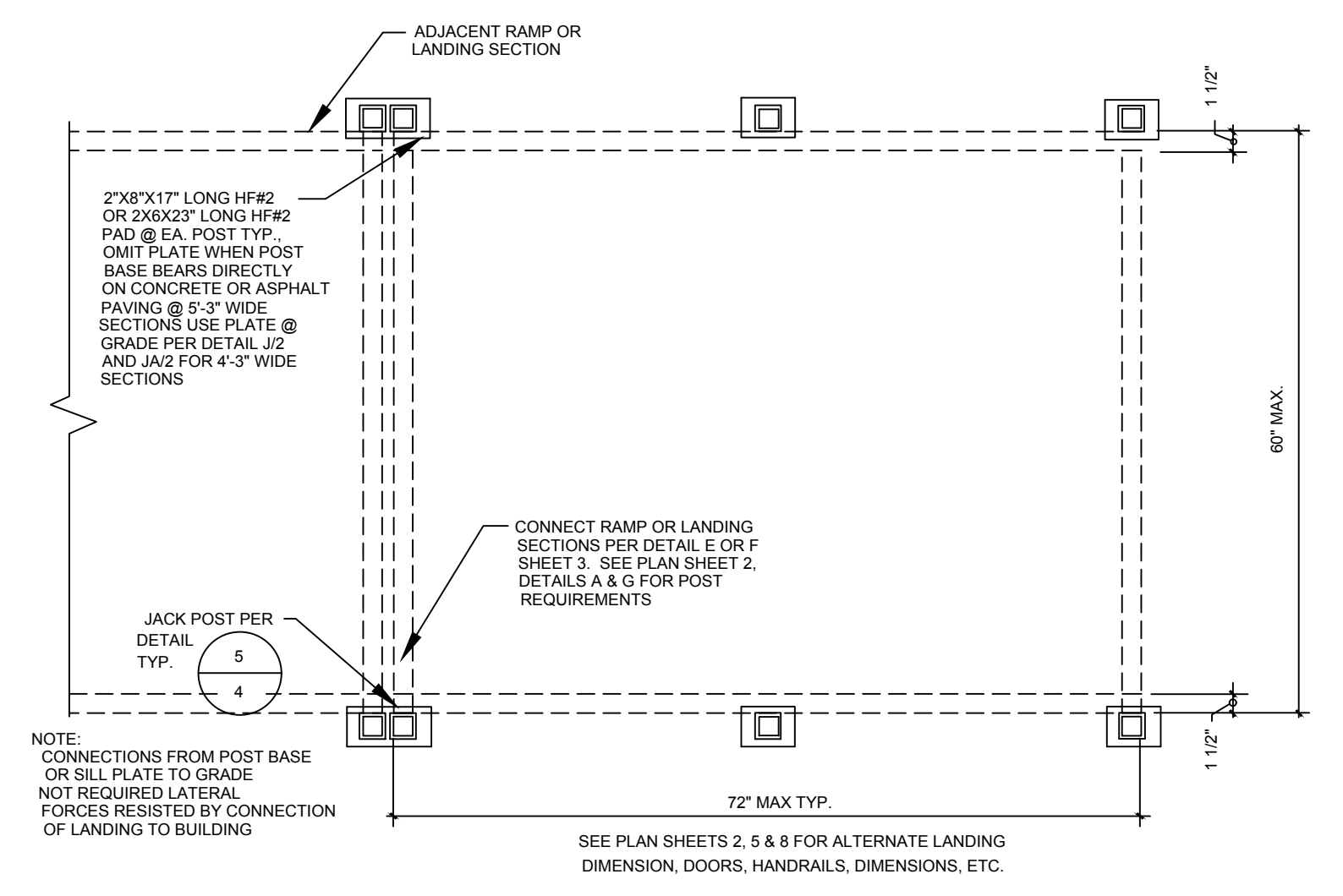

**FOOTINGS @ LANDING OR RAMP SECTION** 1A

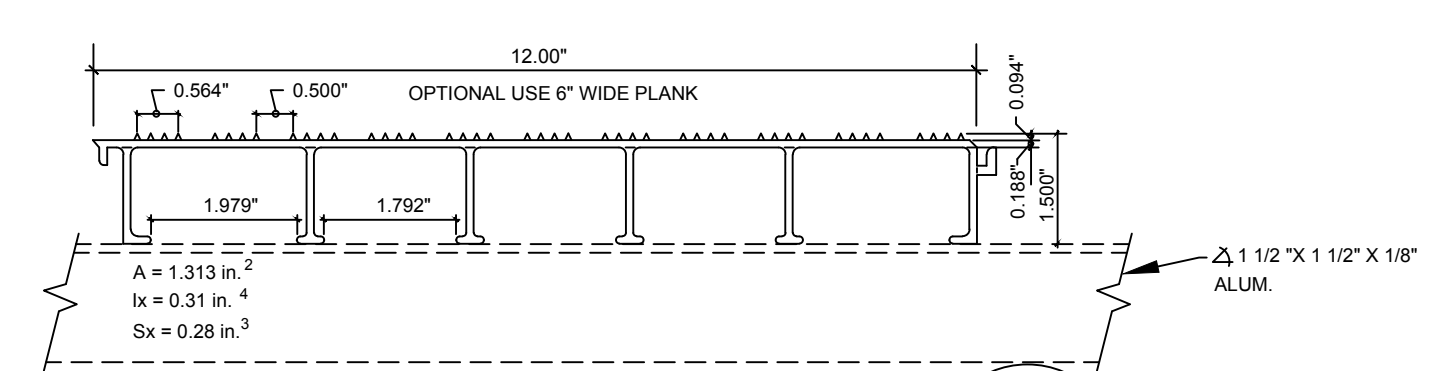

**ALUM. DECK PLANKING** 2

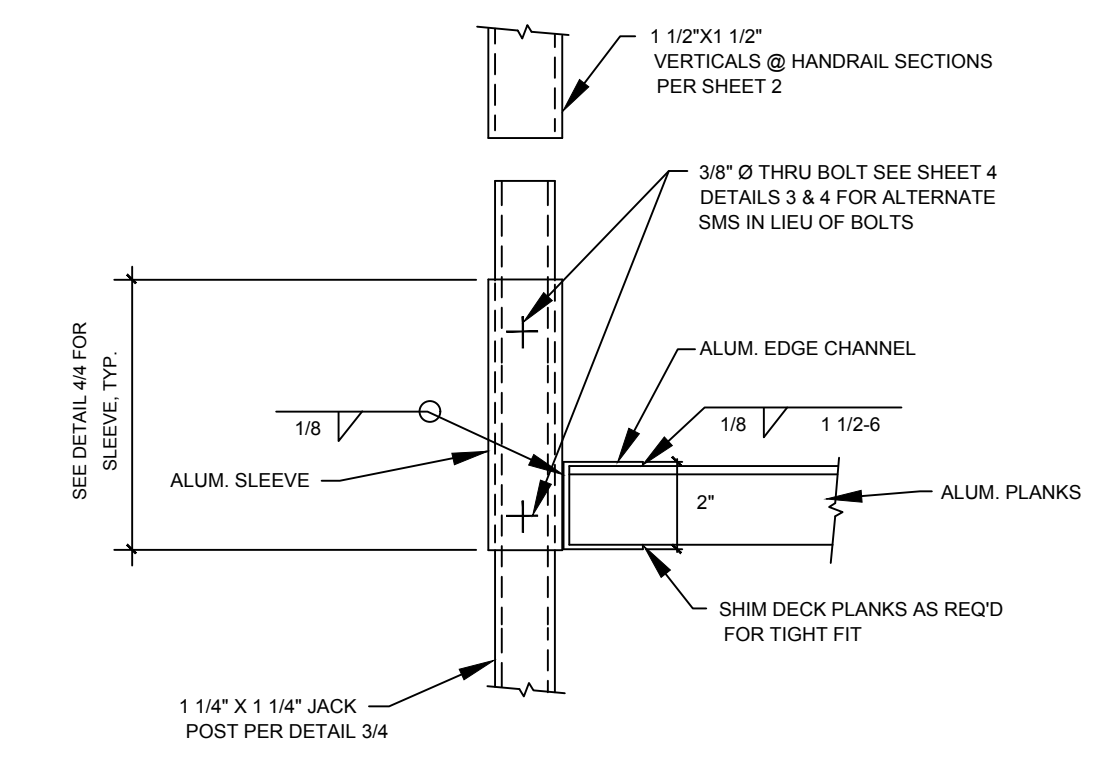

**ALUM. SLEEVE DETAIL** 3

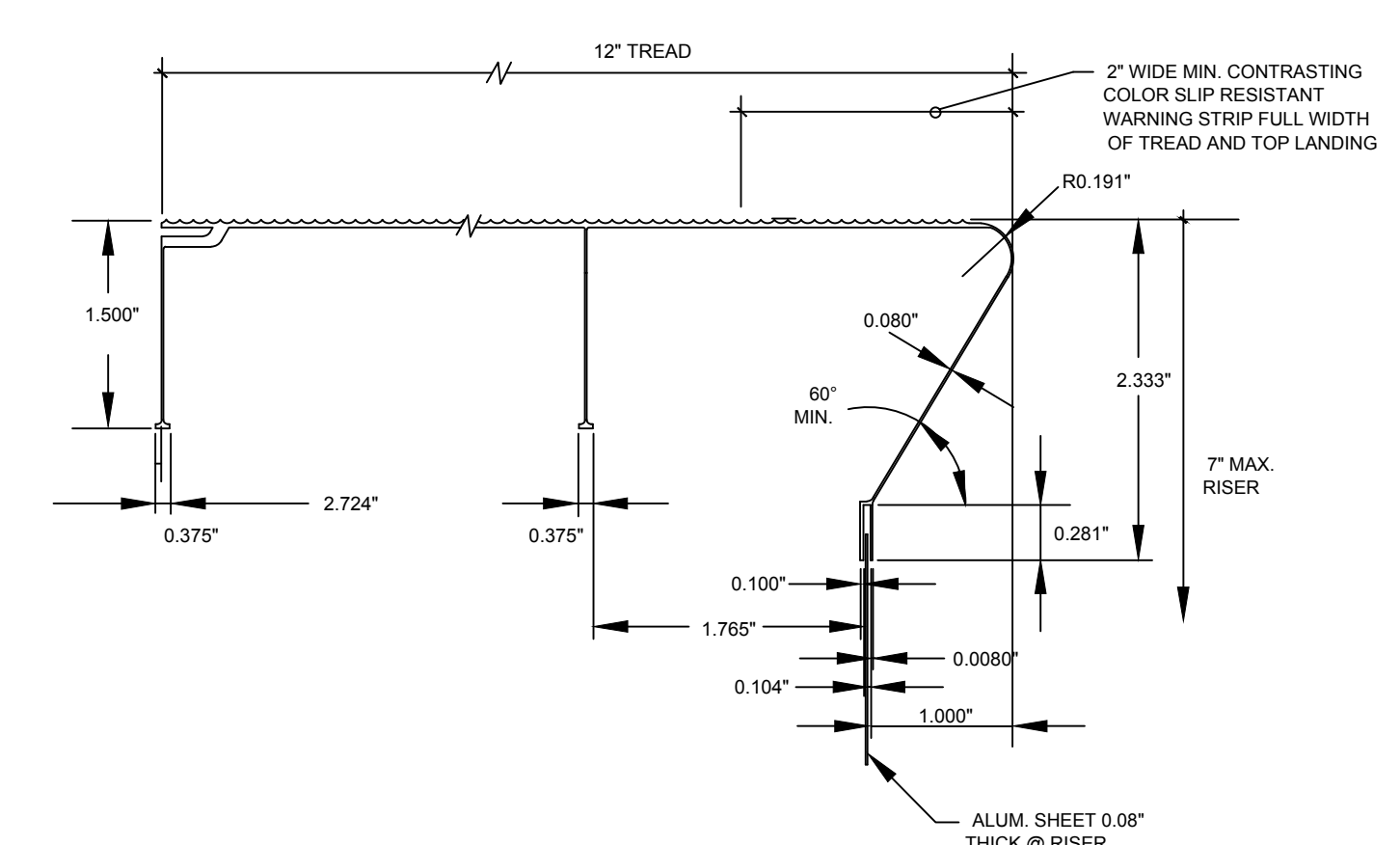

**ALUM. STAIR TREAD** 4

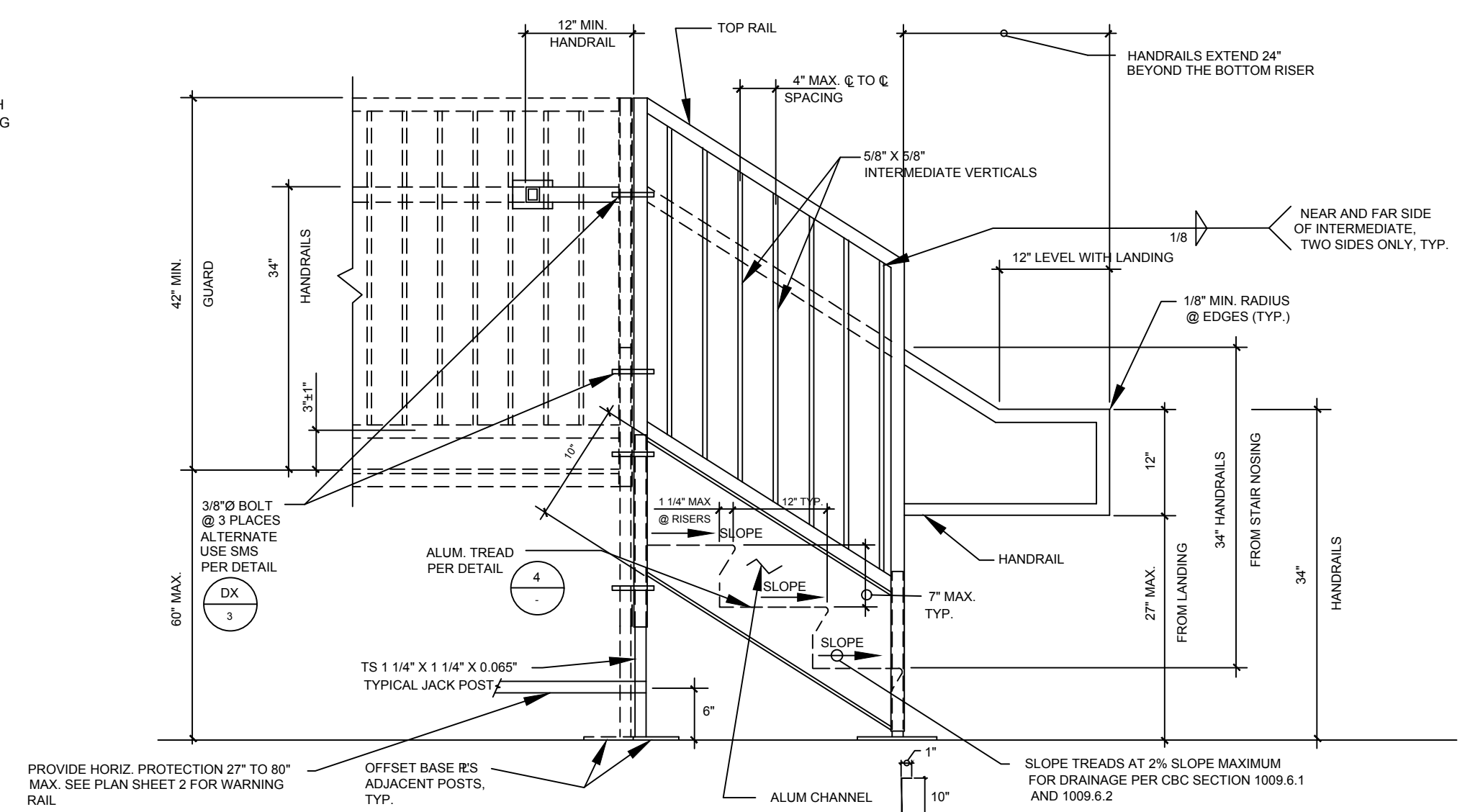

**STAIRS** 5

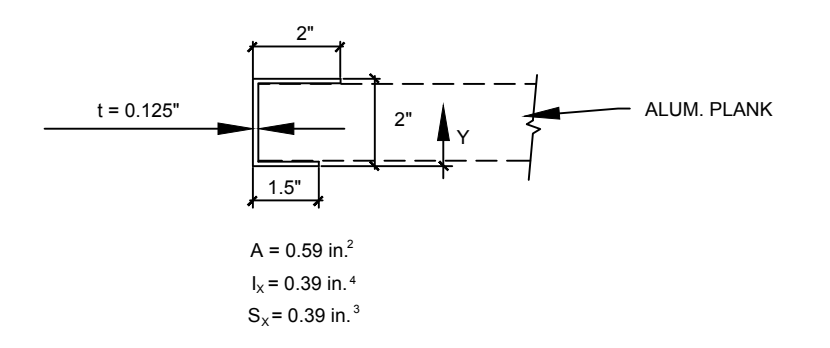

**ALUM. EDGE CHANNEL** 6

**NOTES:**  
 MATERIAL SPECIFICATIONS:  
 ALUMINUM:  
 1 1/4" X 1 1/4" X 1/8 ANGLE 6063 T5  
 2" X 1 1/2" X 1/8" CHANNEL 6063 T5  
 DECK PLANKS 6063 T5  
 STAIR PLANKS 6063 T5  
 BOLTS: ALUMINUM 6061-T6, 2024-T4 OR 7075-T73. ALTERNATE USE TYPE 304 STAINLESS STEEL BOLTS WITH STAINLESS STEEL WASHERS.  
 WELDS: ALL WELDING SHALL CONFORM TO "AMERICAN WELDING SOCIETY D1.2 FOR ALUMINUM". ELECTRODES SHALL BE 5356 OR 5554.  
 SEE SHEET 4 FOR GENERAL NOTES

PRE-CHECK (PC) DOCUMENT  
 CODE: 2019 CBC  
 A SEPARATE PROJECT APPLICATION FOR CONSTRUCTION IS REQUIRED



DATE SIGNED: January 7, 2021

APPROVED  
 DIV. OF THE STATE ARCHITECT  
 APP: 04-119501 PC  
 REVIEWED FOR  
 SS  FLS  ACS  CG   
 DATE: 02/09/2021

ACCESSIBLE RAMP  
 OPTIONAL ALUMINUM DECK  
 TMP SERVICES  
 2929 KANSAS AVE  
 RIVERSIDE, CA 92507  
 PHONE: (951)213-3900  
 FAX: (951)213-3997

SITE: STATE OF CALIFORNIA  
 PC -2019 CBC

DSA APPROVALS

DRAWN  
 CHECKED  
 DATE: 03 FEB 2020  
 SCALE  
 JOB NO.

7 OF 16 SHEETS

NOTE: PICKETS & 42" HIGH GUARD REQUIRED FOR THRESHOLD HEIGHTS GREATER THAN 30" ABOVE FINISH GRADE. FOR THRESHOLD HEIGHTS LESS THAN 30" ABOVE FINISH GRADE, PICKETS CAN BE OMITTED & HANDRAIL WILL ACT AS GUARD.

PROPRIETARY DESIGN: THIS DRAWING AND THE MATERIAL CONTAINED THEREIN ARE THE PROPERTY OF TMP SERVICES, INC. AND SHALL NOT BE REPRODUCED, COPIED OR OTHERWISE DISPOSED OF DIRECTLY OR INDIRECTLY AND SHALL NOT BE USED IN WHOLE OR IN PART TO ASSIST IN THE MAKING OF OR THE PURPOSE OF FURNISHING ANY INFORMATION FOR THE MAKING OF DRAWINGS, PRINTS, APPARATUS OR PARTS THEREOF WITHOUT THE FULL KNOWLEDGE AND CONSENT OF TMP SERVICES, INC. ALL PATENTABLE MATERIAL CONTAINED HEREIN AND ORIGINATED WITH TMP SERVICES, INC. SHALL BE THE PROPERTY OF TMP SERVICES, INC.

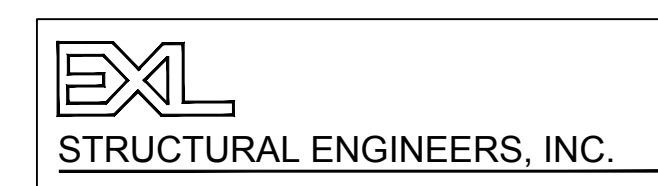

4091 RIVERSIDE DRIVE, SUITE 114  
 CHINO, CALIFORNIA 91710

MEMBER  
 STRUCTURAL ENGINEERS ASSOCIATION OF CALIFORNIA  
 AMERICAN CONCRETE INSTITUTE  
 (909) 613-0234

TMP DSA RAMP & LANDING STEEL SHEET 7.DWG



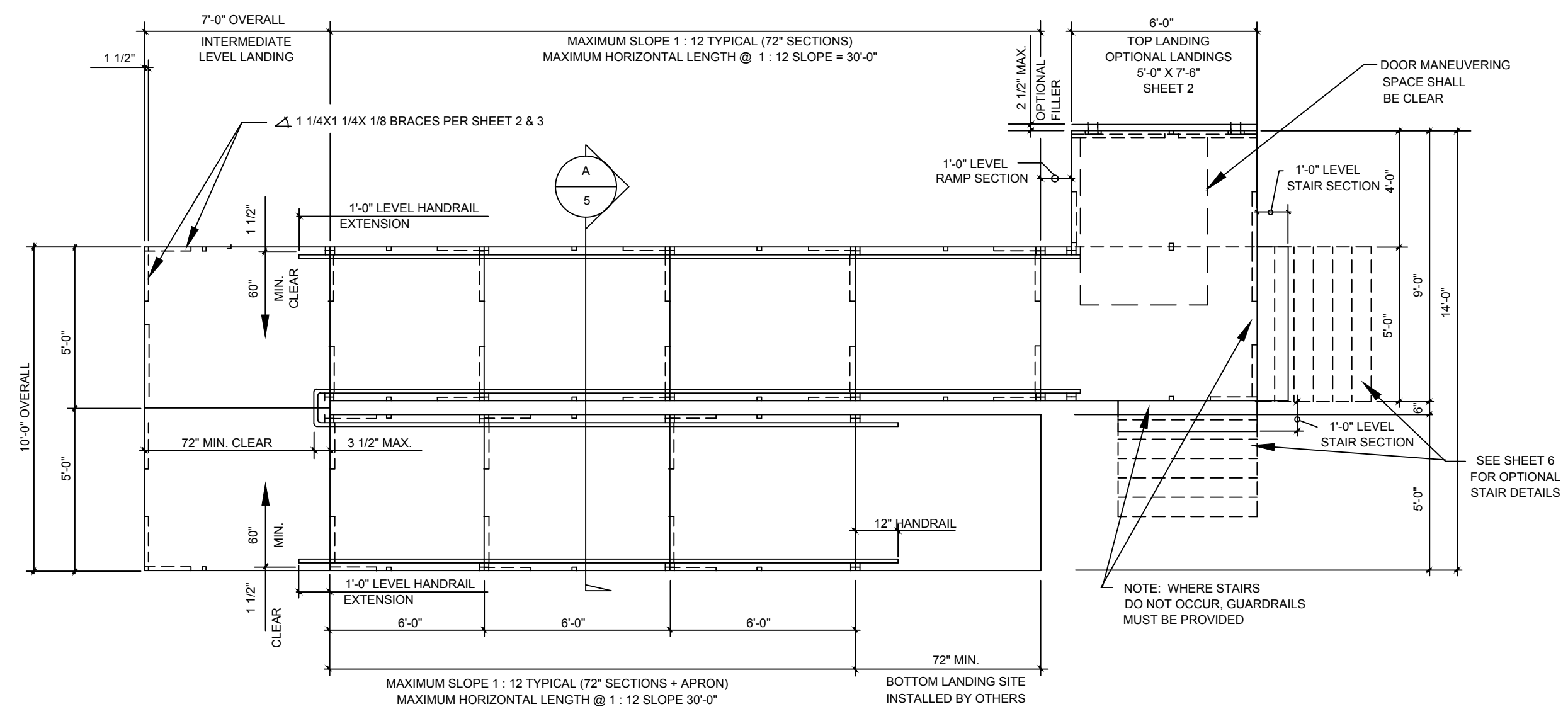

TYPICAL PLAN VIEW OF ACCESSIBLE RAMP WITH SWITCH-BACK & PLATFORMS

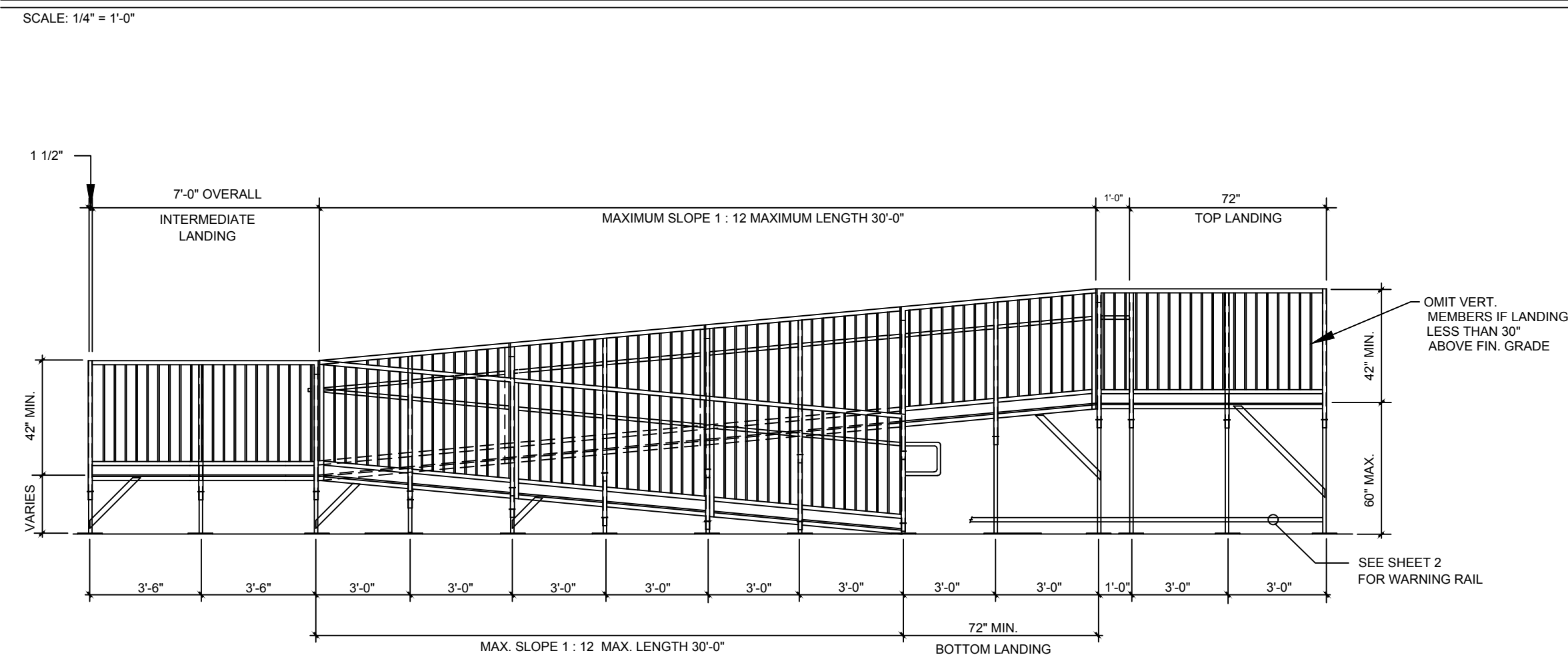

TYPICAL ELEVATION OF ACCESSIBLE RAMP W/SWITCH-BACK RAMP W/ 5'-0" WIDE RAMPS

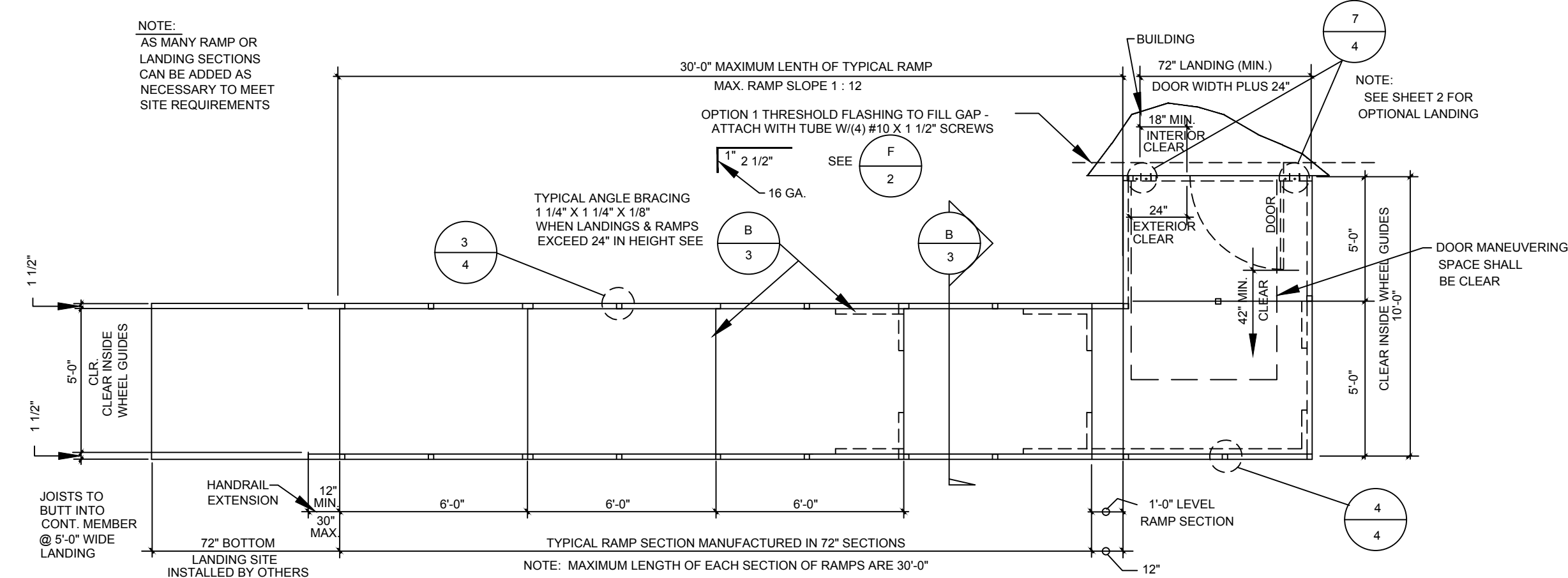

TYPICAL PLAN VIEW OF ACCESSIBLE RAMP & DECK LAYOUT

SCALE: 1/4" = 1'-0"

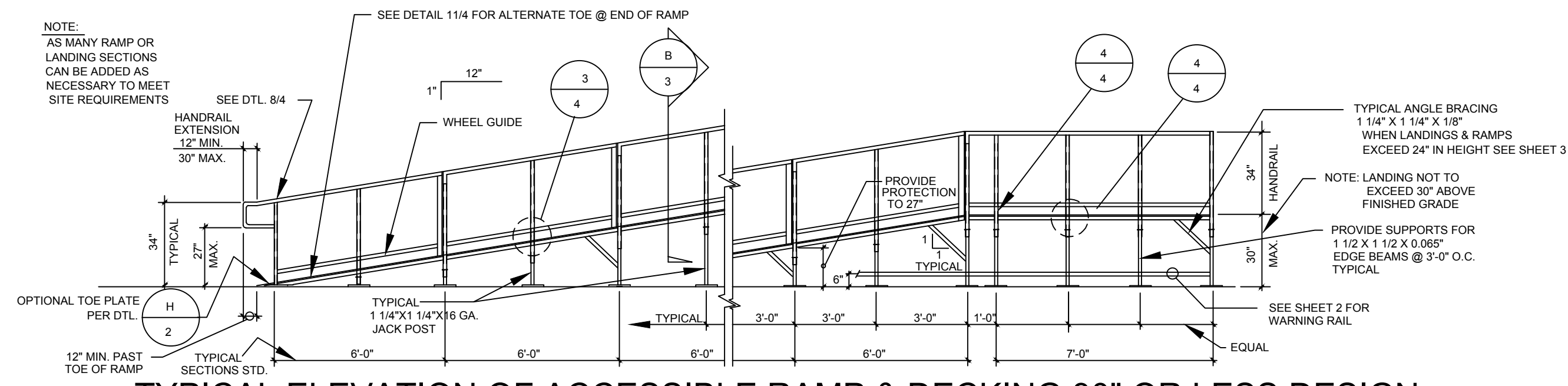

TYPICAL ELEVATION OF ACCESSIBLE RAMP & DECKING 30" OR LESS DESIGN

SCALE: 1/4" = 1'-0"

NOTE: SEE PLAN SHEET 3 FOR HANDRAIL SIZES

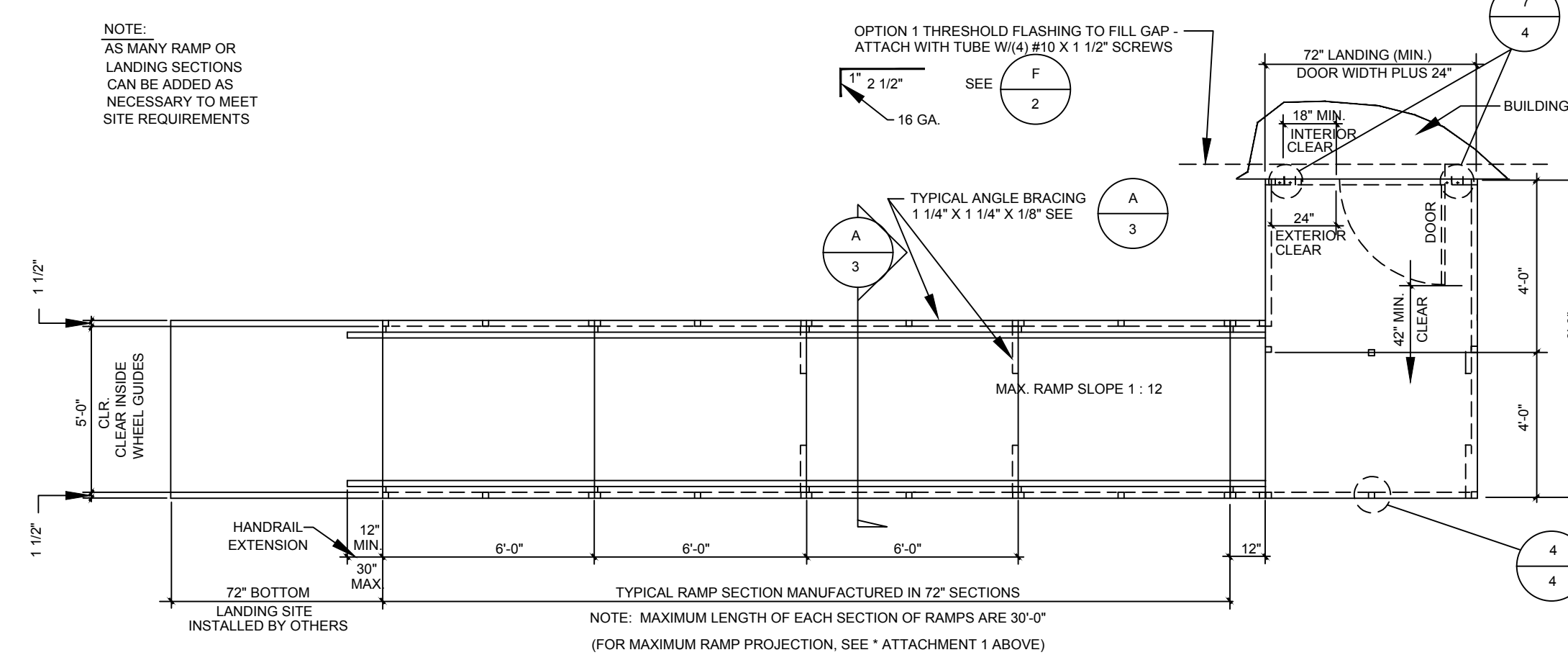

TYPICAL PLAN VIEW OF ACCESSIBLE RAMP & DECK LAYOUT OVER 30" DESIGN

SCALE: 1/4" = 1'-0"

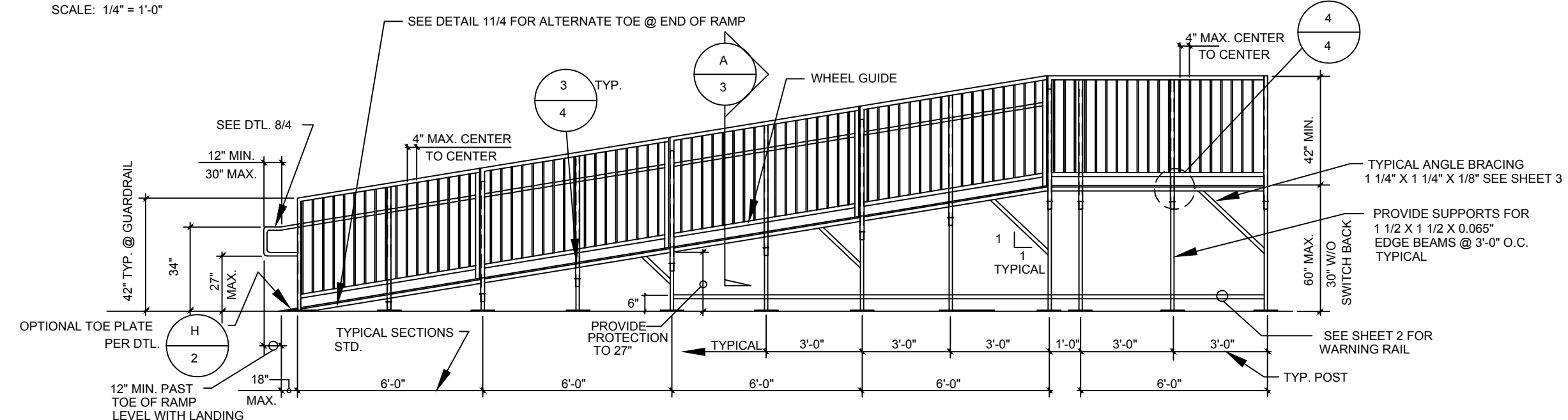

TYPICAL ELEVATION OF ACCESSIBLE RAMP & DECKING

SCALE: 1/4" = 1'-0"

NOTE: SEE PLAN SHEET 3 FOR HANDRAIL/GUARDRAIL SIZES

PROPRIETARY DESIGN: THIS DRAWING AND THE MATERIAL CONTAINED THEREIN ARE THE PROPERTY OF TMP SERVICES, INC. AND SHALL NOT BE REPRODUCED, COPIED OR OTHERWISE DISPOSED OF DIRECTLY OR INDIRECTLY AND SHALL NOT BE USED IN WHOLE OR IN PART TO ASSIST IN THE MAKING OF OR THE PURPOSE OF FURNISHING ANY INFORMATION FOR THE MAKING OF DRAWINGS, PRINTS, APPARATUS OR PARTS THEREOF WITHOUT THE FULL KNOWLEDGE AND CONSENT OF TMP SERVICES, INC. ALL PATENTABLE MATERIAL CONTAINED HEREIN AND ORIGINATED WITH TMP SERVICES, INC. SHALL BE THE PROPERTY OF TMP SERVICES, INC.

**EXL**  
STRUCTURAL ENGINEERS, INC.

4091 RIVERSIDE DRIVE, SUITE 114  
CHINO, CALIFORNIA 91710

MEMBER  
STRUCTURAL ENGINEERS  
ASSOCIATION OF CALIFORNIA  
AMERICAN CONCRETE  
INSTITUTE  
(909) 613-0234

DSA APPROVALS

SITE: \_\_\_\_\_  
STATE OF CALIFORNIA  
-2019 CBC  
PC

DRAWN

CHECKED

DATE  
03 FEB 2020

SCALE

JOB NO.

8

8 OF 16 SHEETS

PRE-CHECK (PC) DOCUMENT  
CODE: 2019 CBC  
A SEPARATE PROJECT  
APPLICATION FOR CONSTRUCTION  
IS REQUIRED



DATE SIGNED January 7, 2021

APPROVED  
DIV. OF THE STATE ARCHITECT  
APP: 04-119501 PC  
REVIEWED FOR  
SS  FLS  ACS  CG   
DATE: 02/09/2021

ACCESSIBLE RAMP  
ELEVATIONS & PLAN VIEWS

TMP SERVICES  
2929 KANSAS AVE  
RIVERSIDE, CA 92507  
PHONE: (951)213-3900  
FAX: (951)213-3997







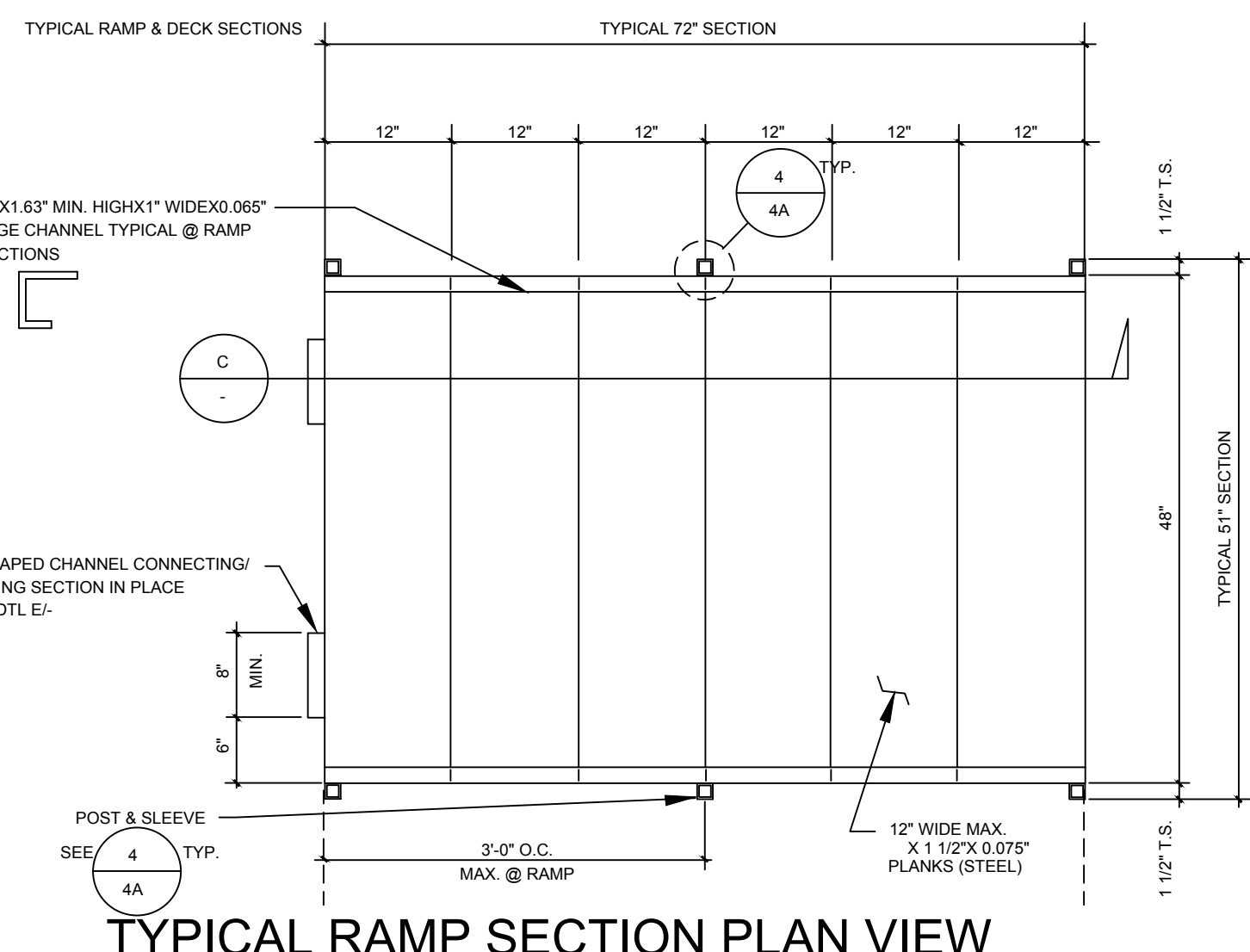

TYPICAL RAMP SECTION PLAN VIEW

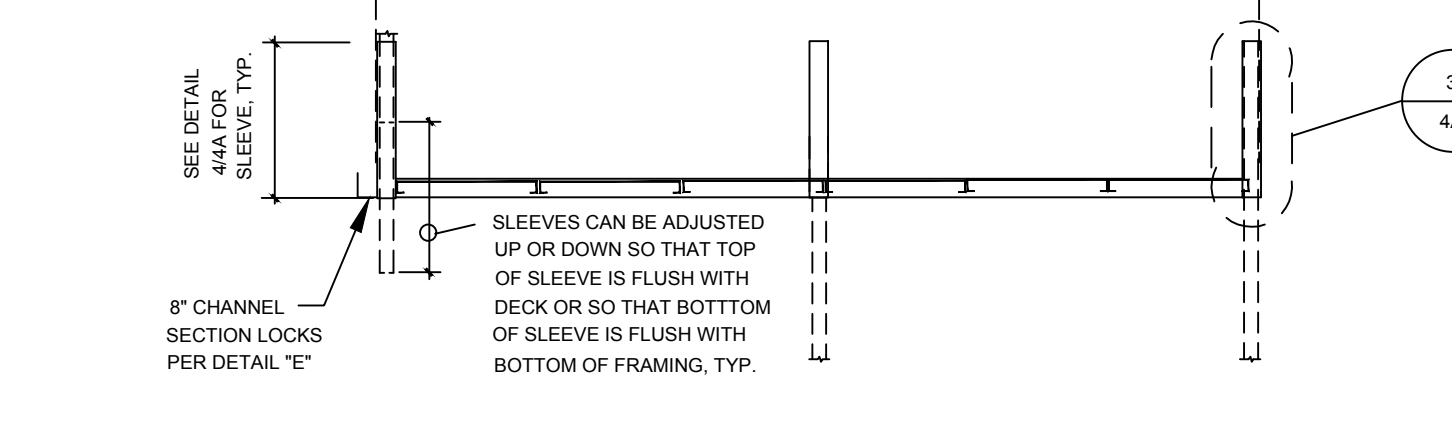

SIDE/END VIEW OF LEVEL DECK SECTION

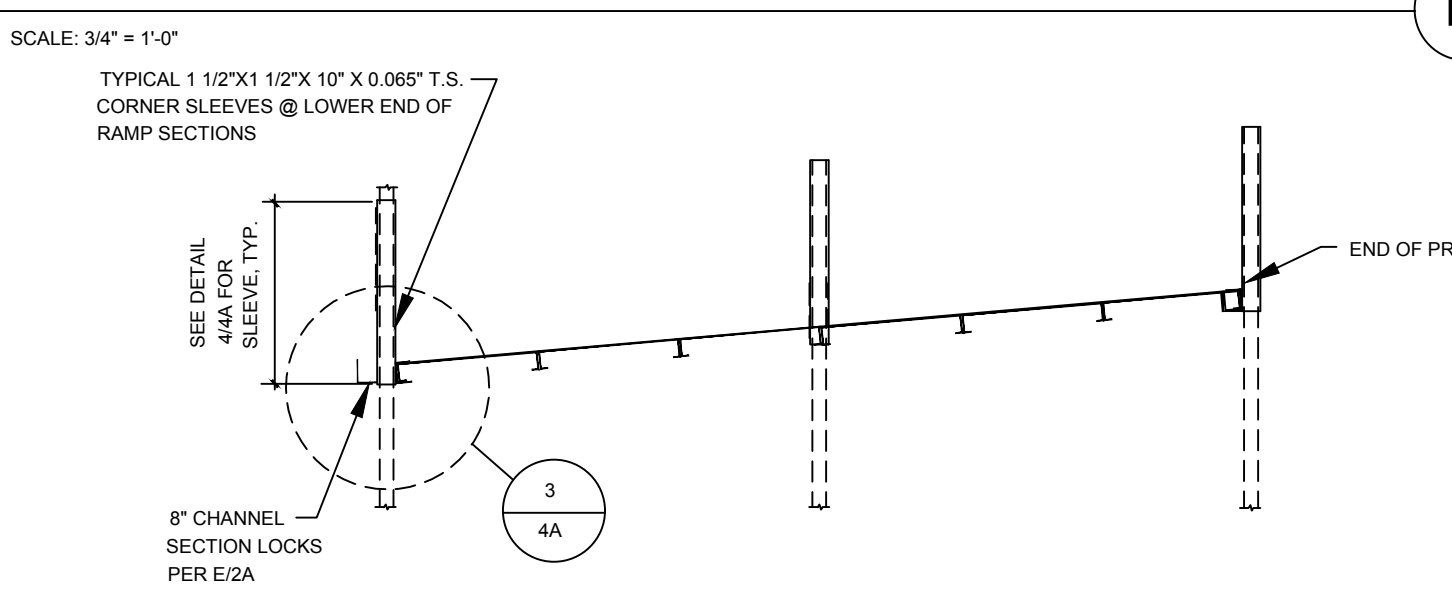

SIDE VIEW OF SLOPING RAMP SECTION TYPICAL

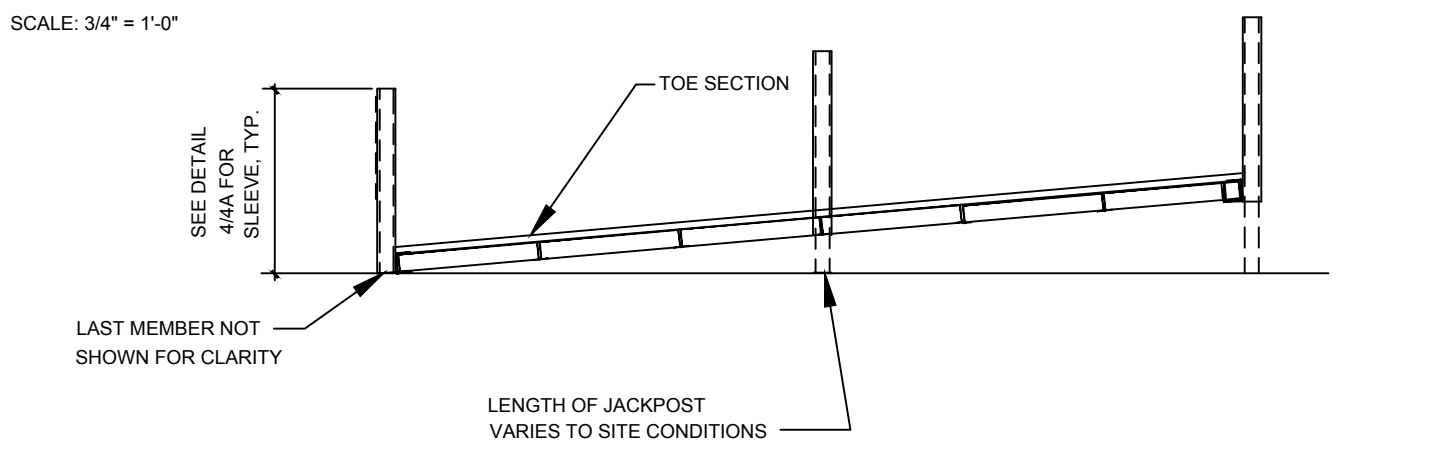

TOE SECTION

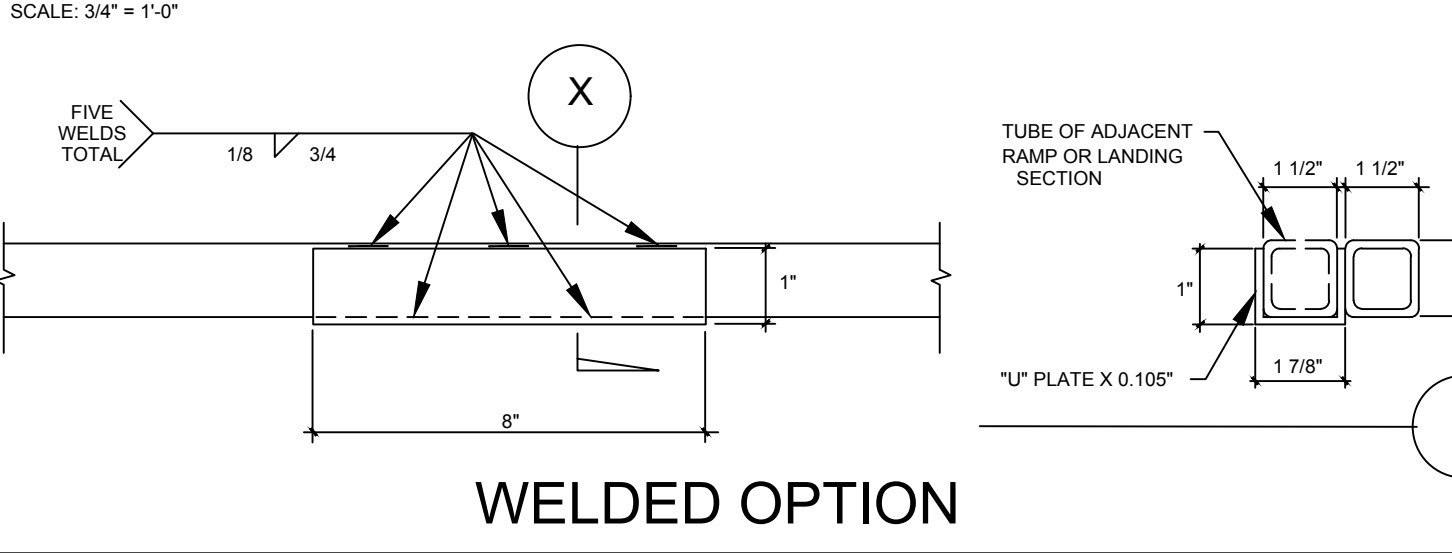

WELDED OPTION

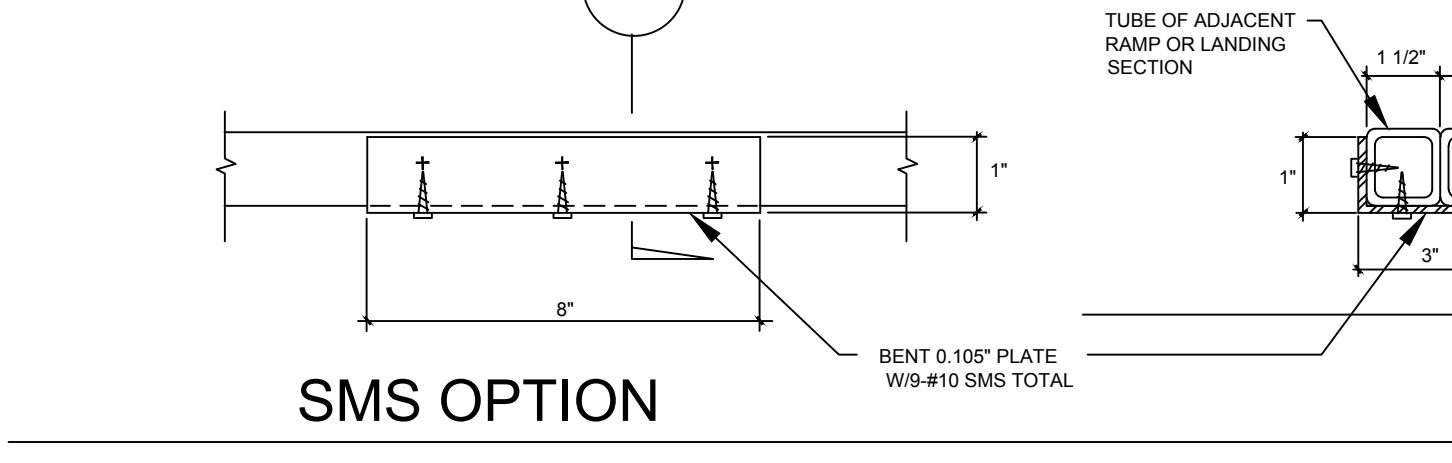

SMS OPTION

8" CHANNEL SECTION

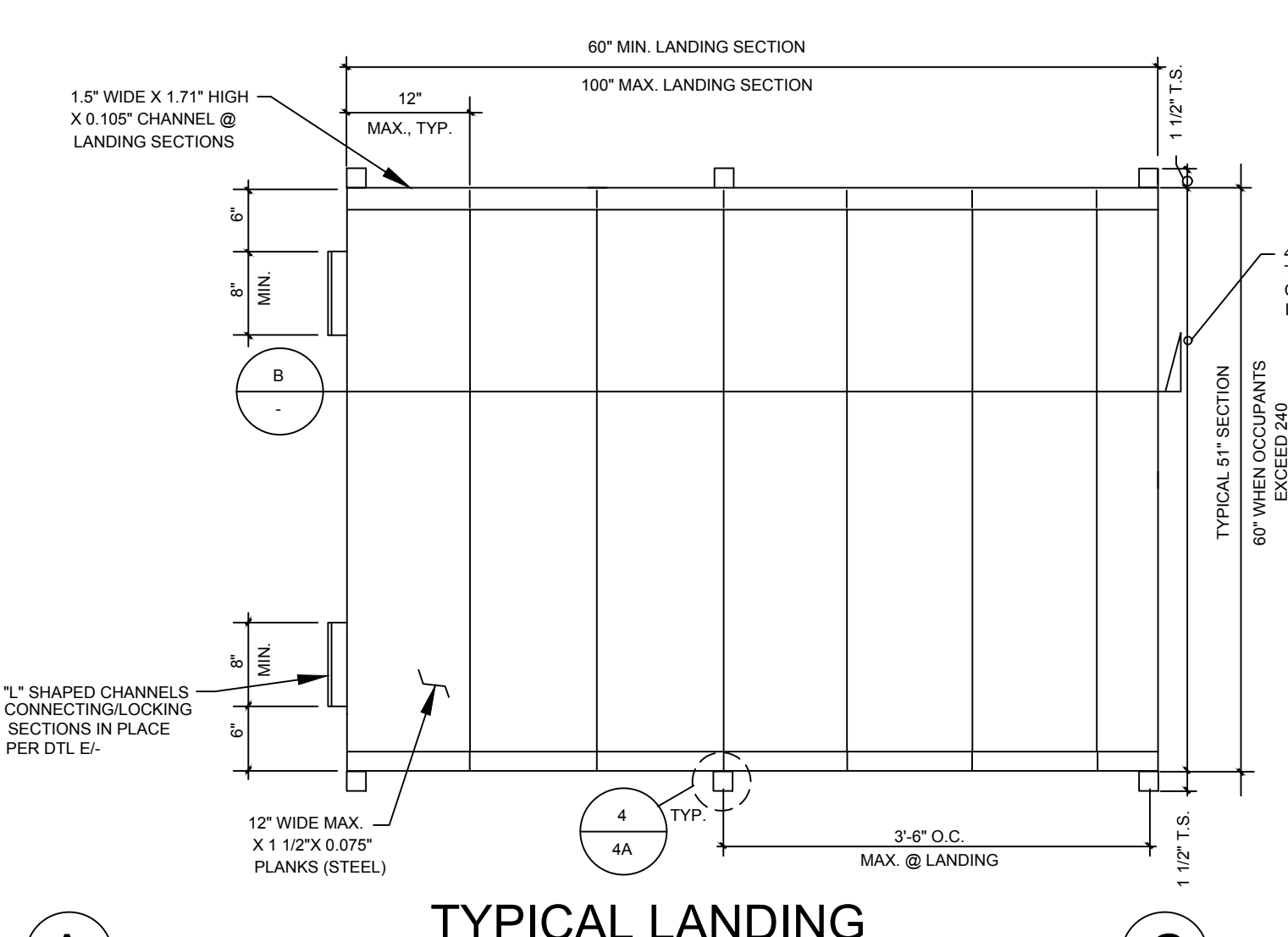

TYPICAL LANDING

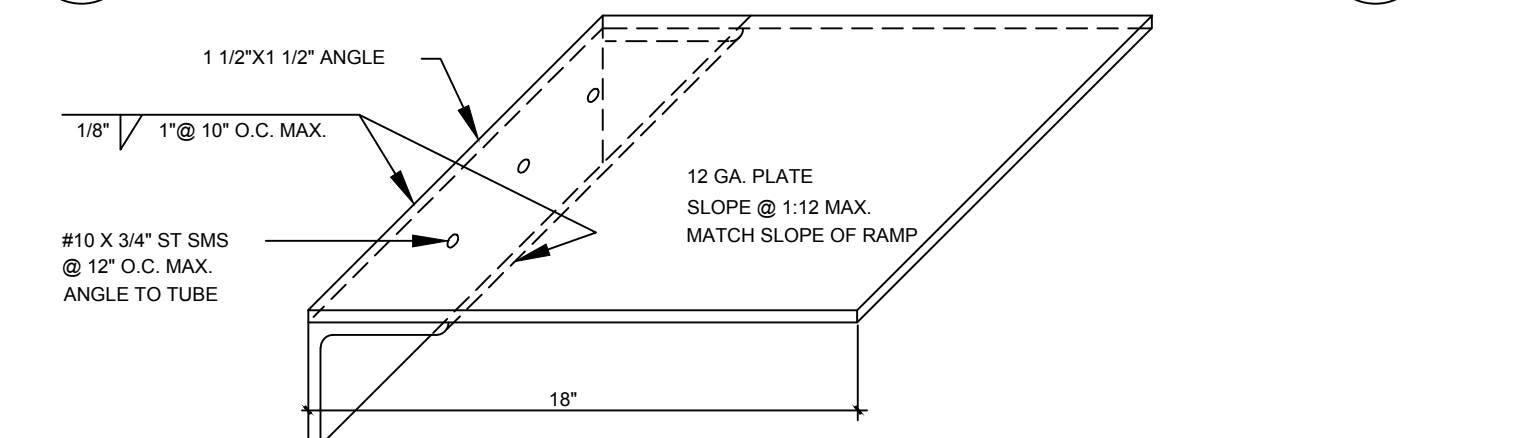

OPTIONAL TOE PLATE

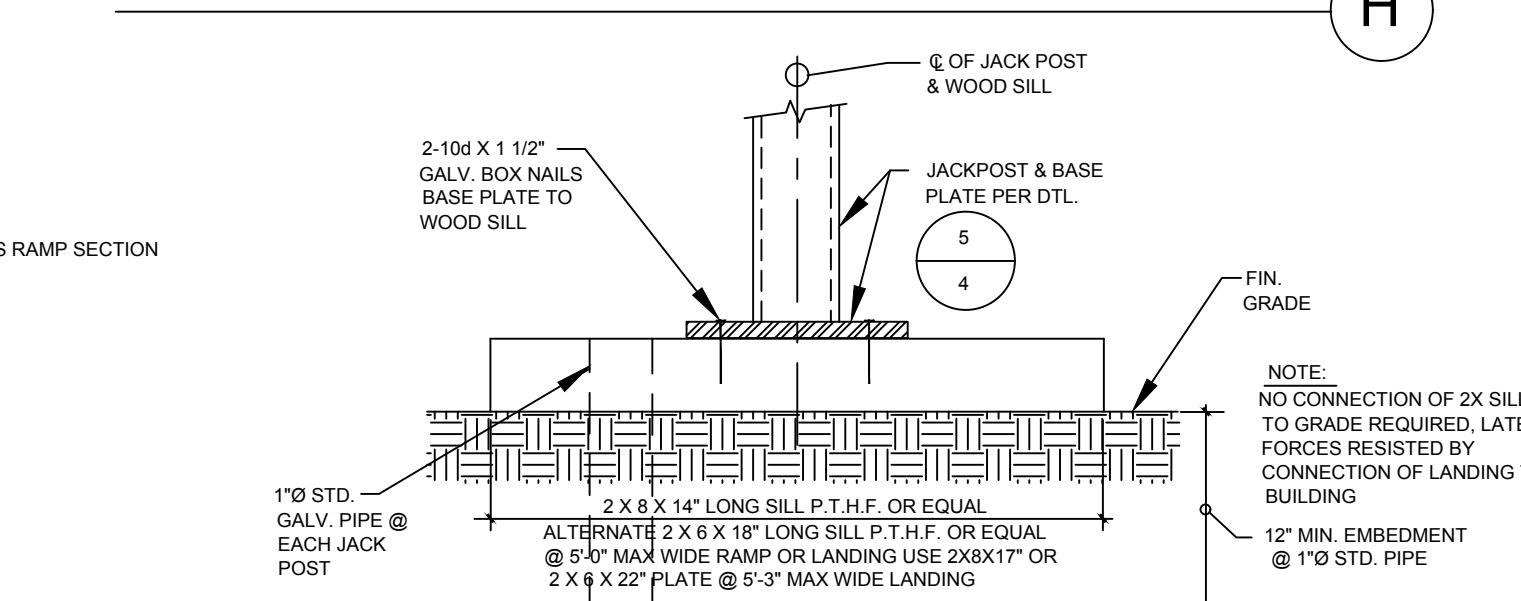

ALTERNATE WOOD SILLS @ JACK POST TO GRADE WHERE CONCRETE OR AC PAVING DOES NOT OCCUR



JACK POST TO PAVING

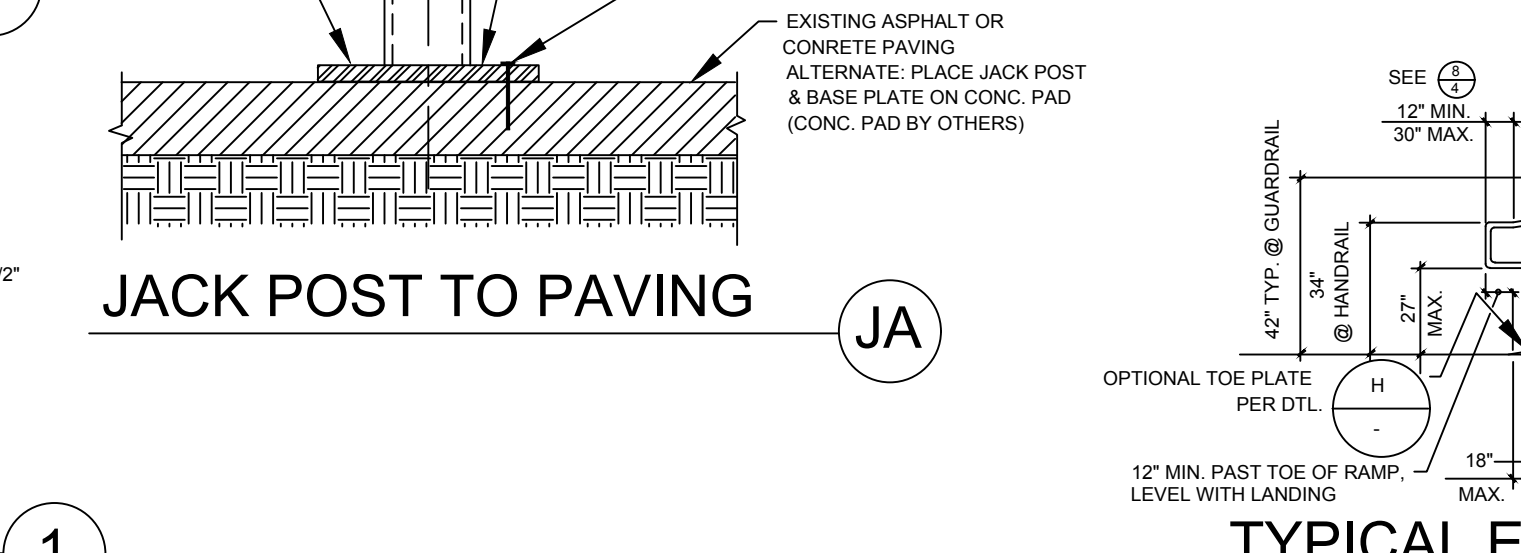

WELDED OPTION

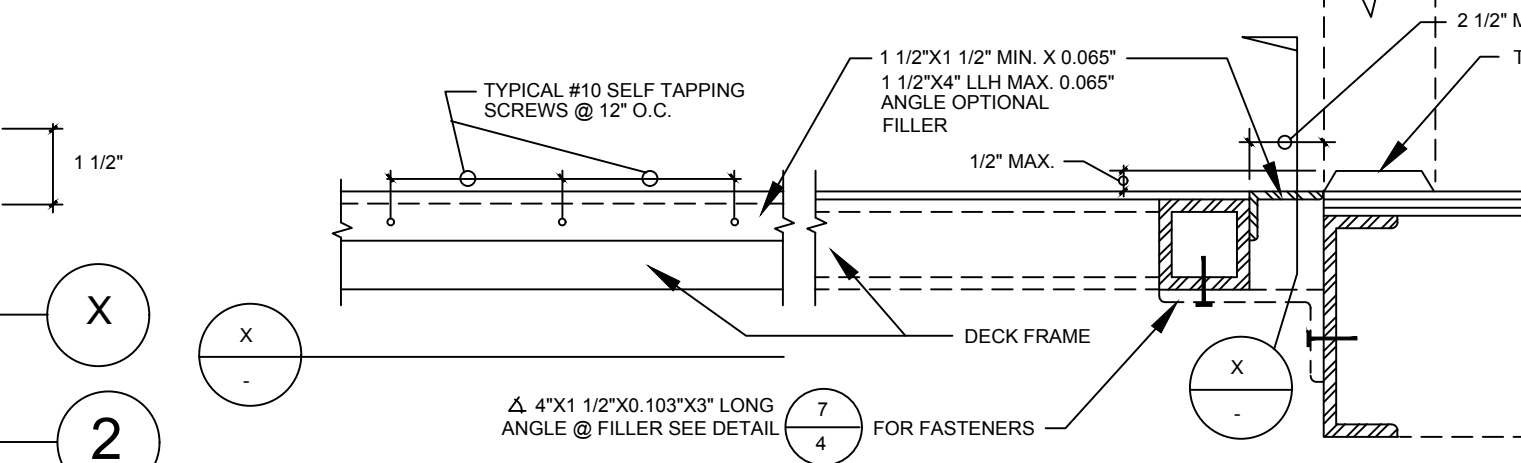

SMS OPTION

8" CHANNEL SECTION

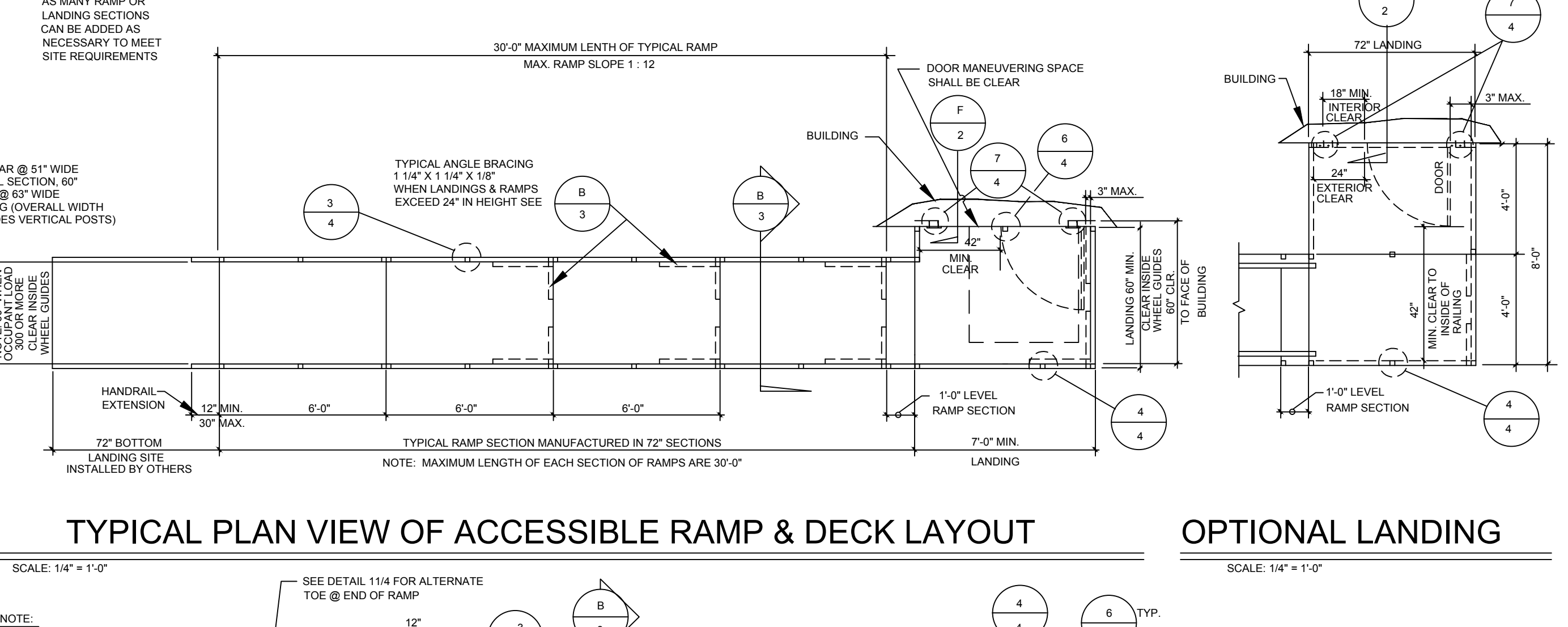

TYPICAL PLAN VIEW OF ACCESSIBLE RAMP & DECK LAYOUT

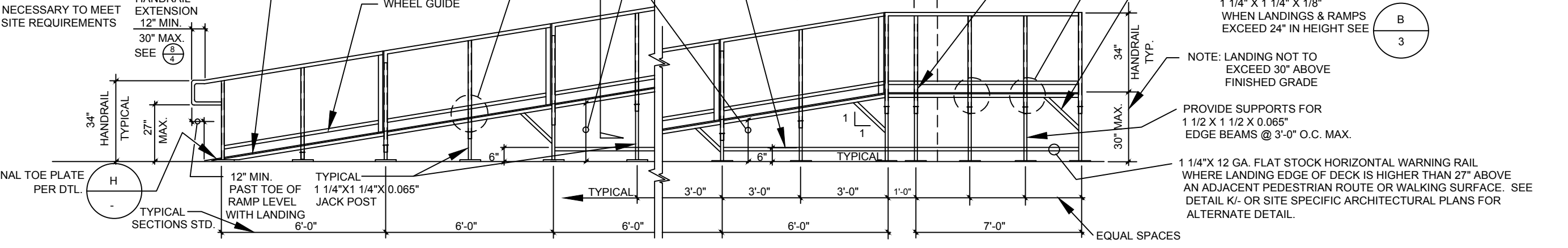

TYPICAL ELEVATION OF ACCESSIBLE RAMP & DECKING 30" OR LESS

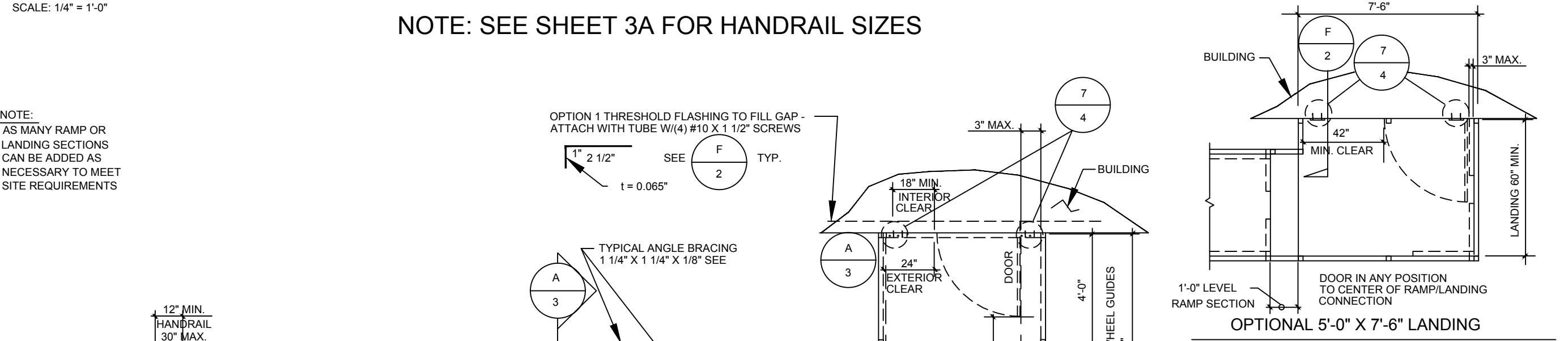

TYPICAL PLAN VIEW OF ACCESSIBLE RAMP & DECK LAYOUT OVER 30" DESIGN

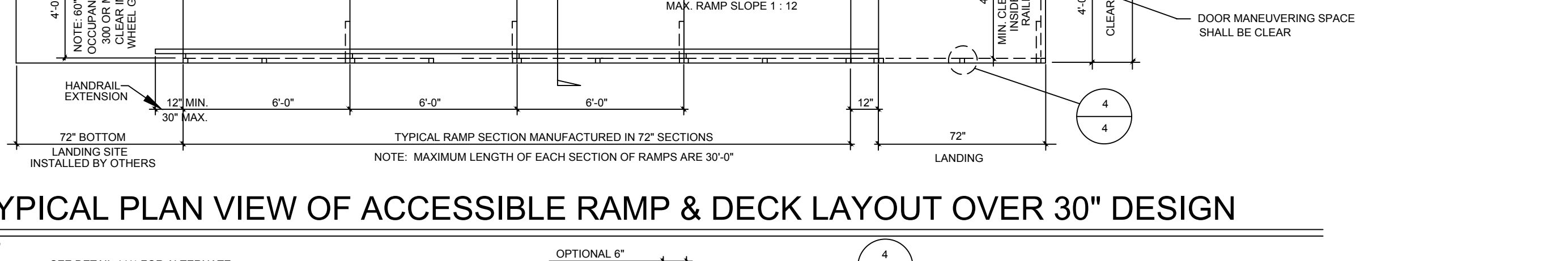

TYPICAL ELEVATION OF ACCESSIBLE RAMP & DECKING

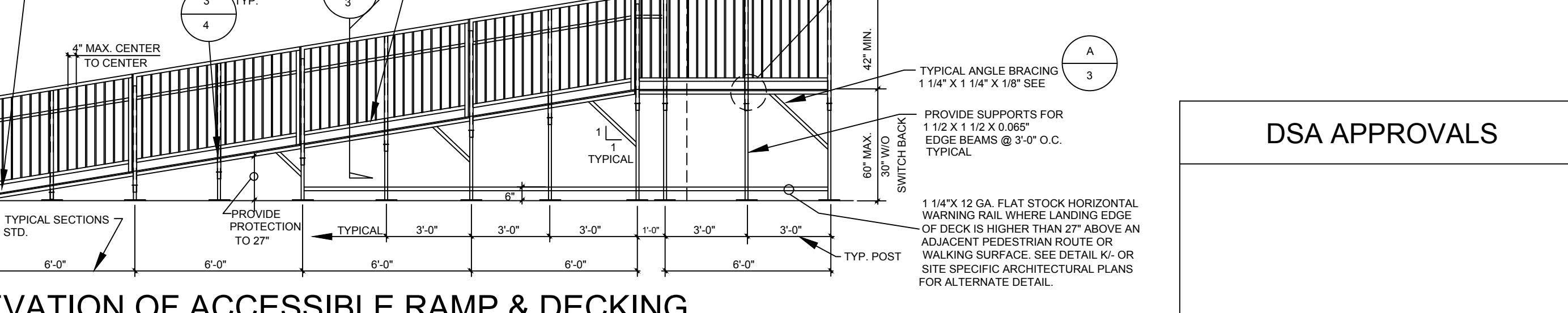

FILLER DETAIL

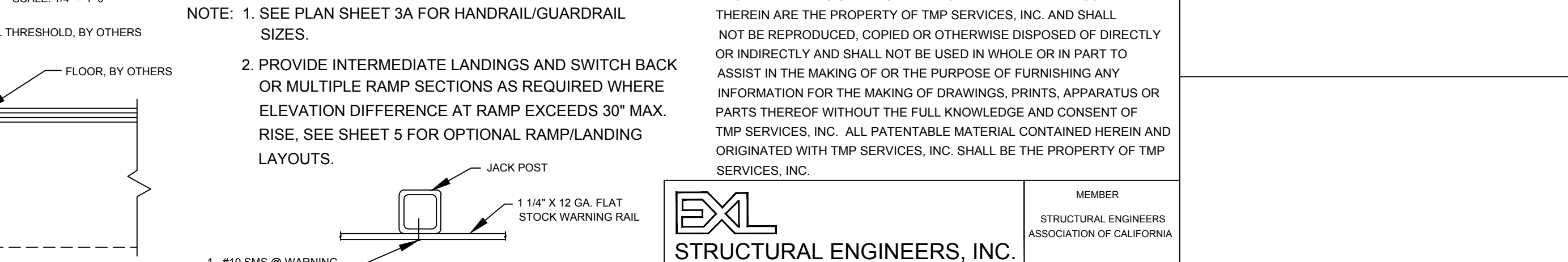

8" CHANNEL SECTION

8" CHANNEL SECTION

PRE-CHECK (PC) DOCUMENT  
 CODE: 2019 CBC  
 A SEPARATE PROJECT APPLICATION FOR CONSTRUCTION IS REQUIRED

REGISTERED PROFESSIONAL ENGINEER  
 JAMES T. SIMPSON  
 No. 3602  
 STRUCTURAL ENGINEERS  
 STATE OF CALIFORNIA

January 7, 2021  
 DATE SIGNED

APPROVED  
 DIV. OF THE STATE ARCHITECT  
 APP: 04-119501 PC  
 REVIEWED FOR  
 SS  FLS  ACS  CG   
 DATE: 02/09/2021

ACCESSIBLE RAMP ELEVATIONS & DETAILS  
 TMP SERVICES  
 2929 KANSAS AVE.  
 RIVERSIDE, CA 92507  
 PHONE: (951)213-3900  
 FAX: (951)213-3997

STATE OF CALIFORNIA  
 PC  
 -2019 CBC

DRAWN  
 CHECKED  
 DATE  
 03 FEB 2020  
 SCALE  
 JOB NO.

MEMBER  
 STRUCTURAL ENGINEERS ASSOCIATION OF CALIFORNIA  
 AMERICAN CONCRETE INSTITUTE  
 (909)613-0234







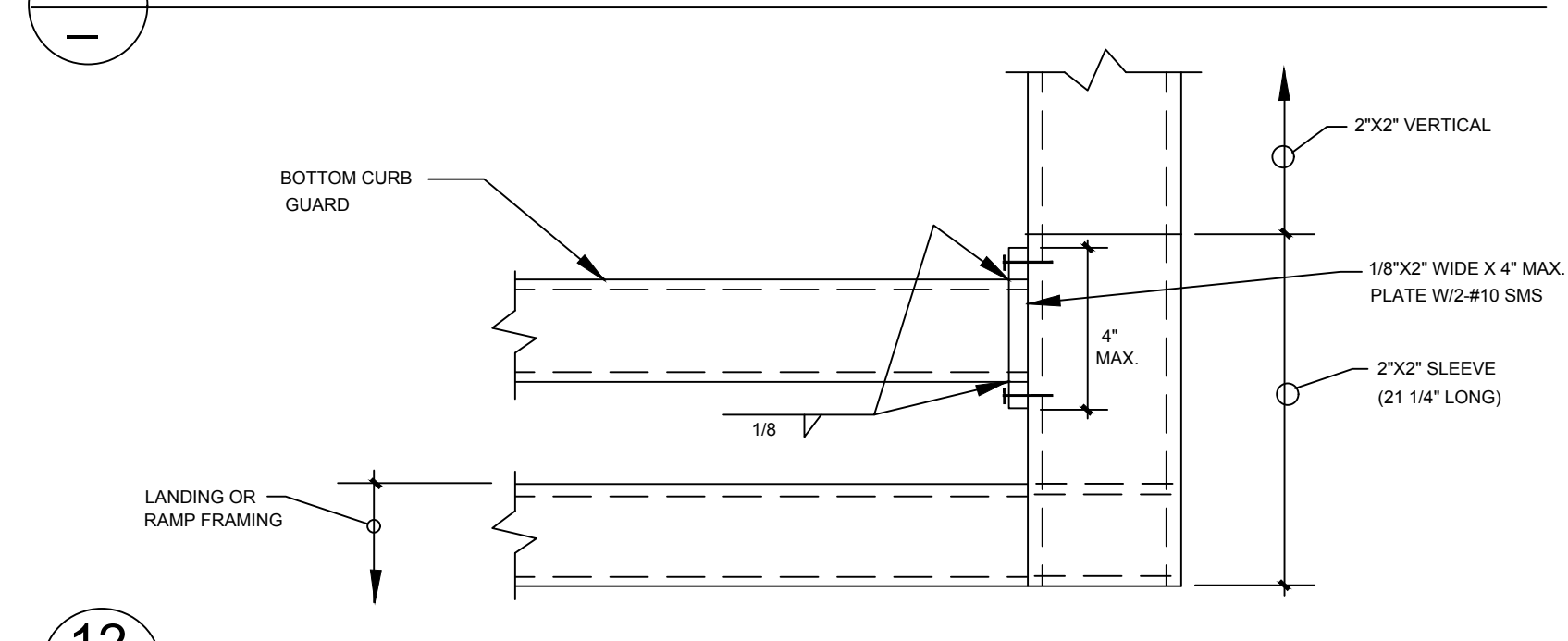
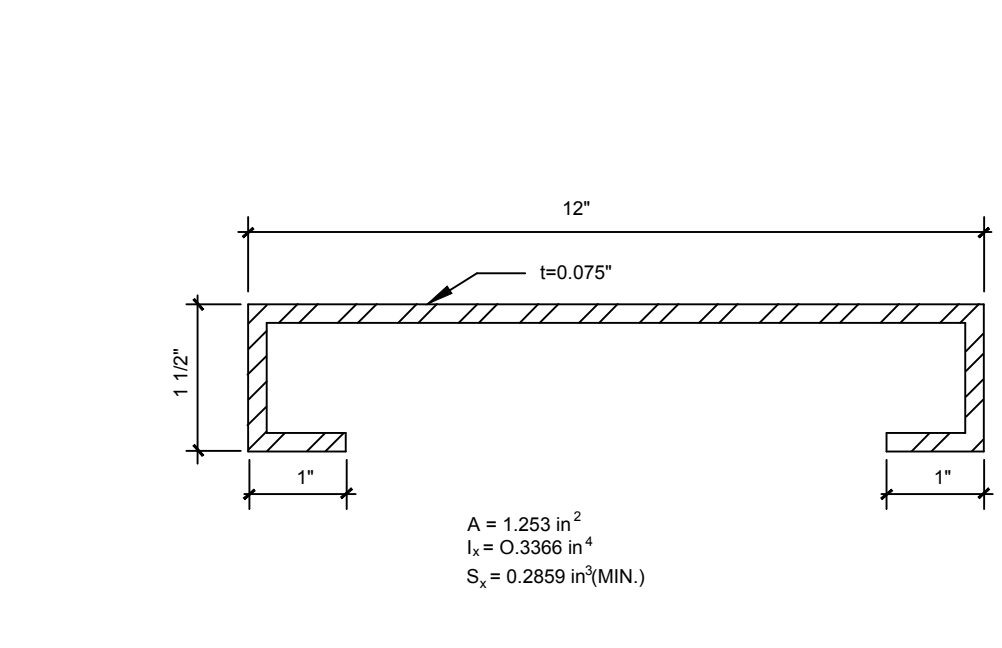
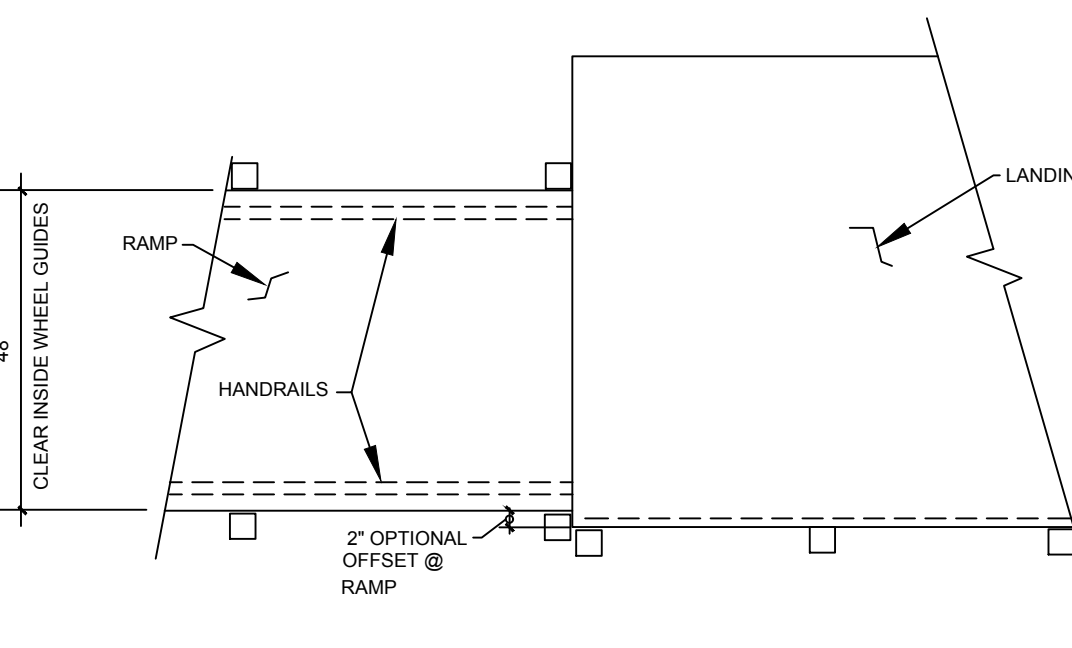
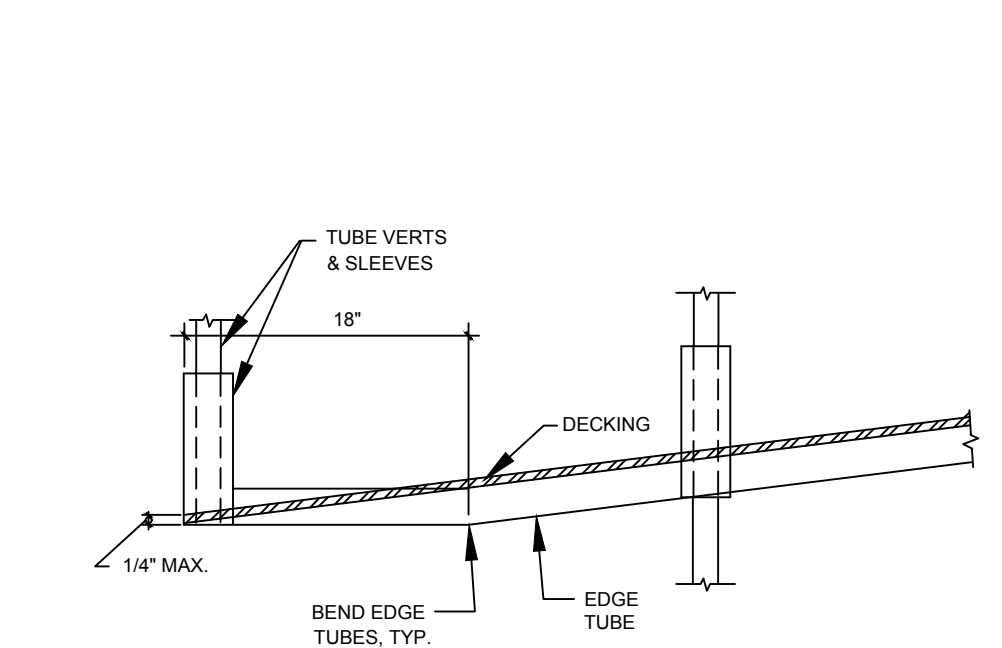
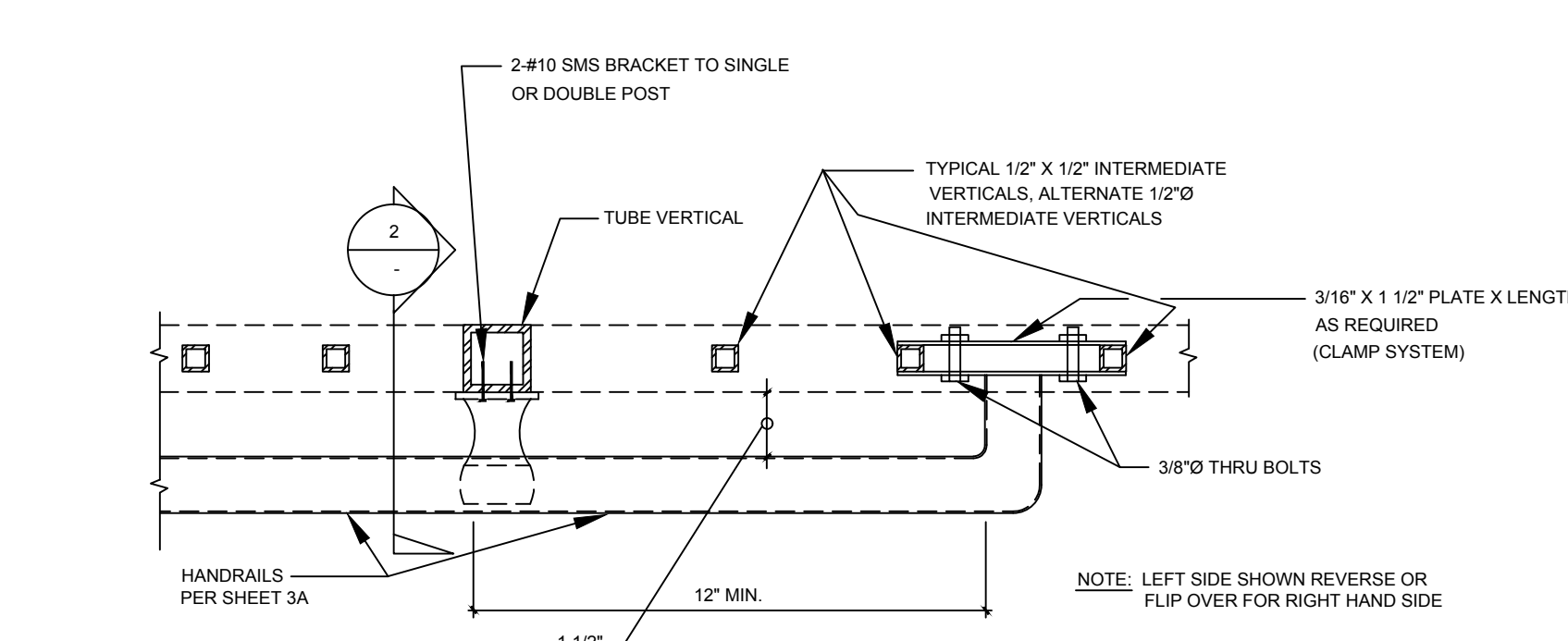
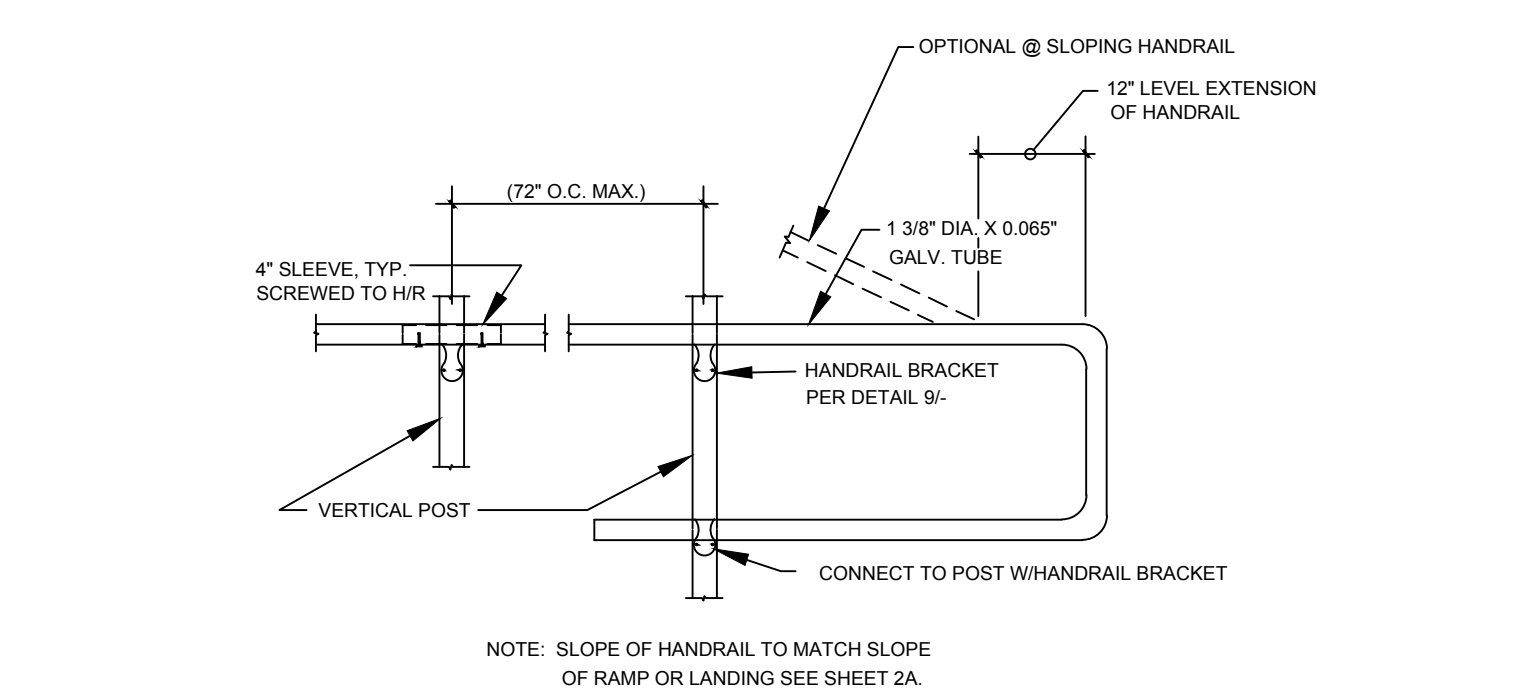
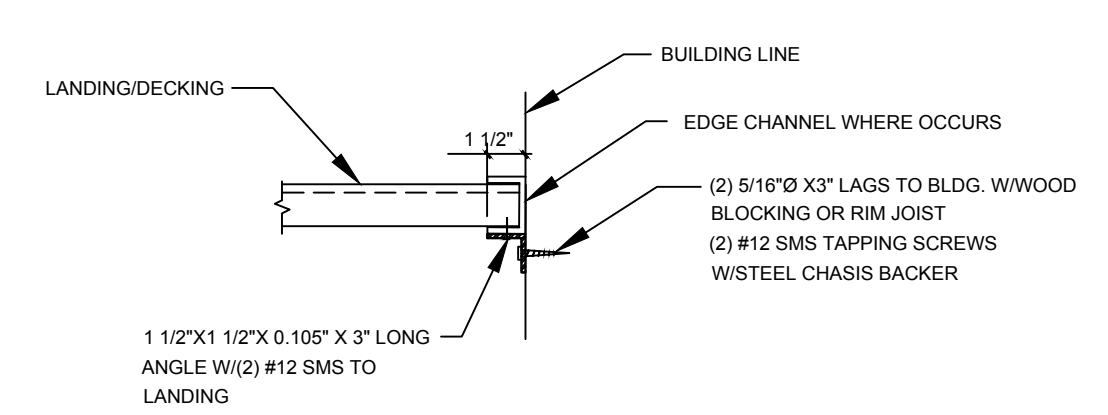
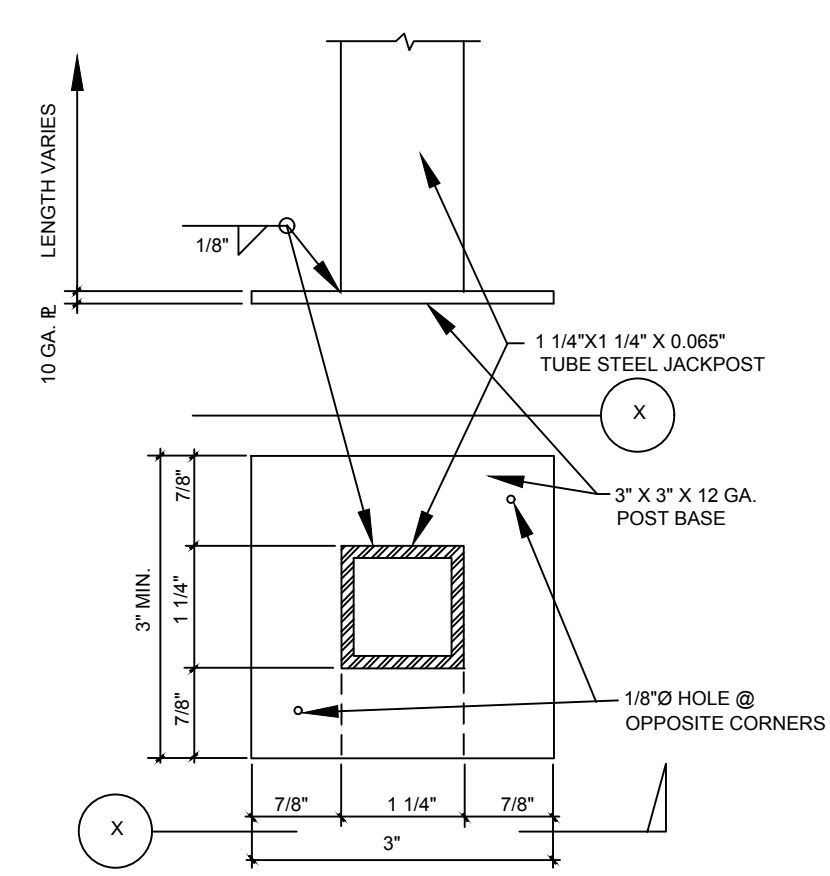
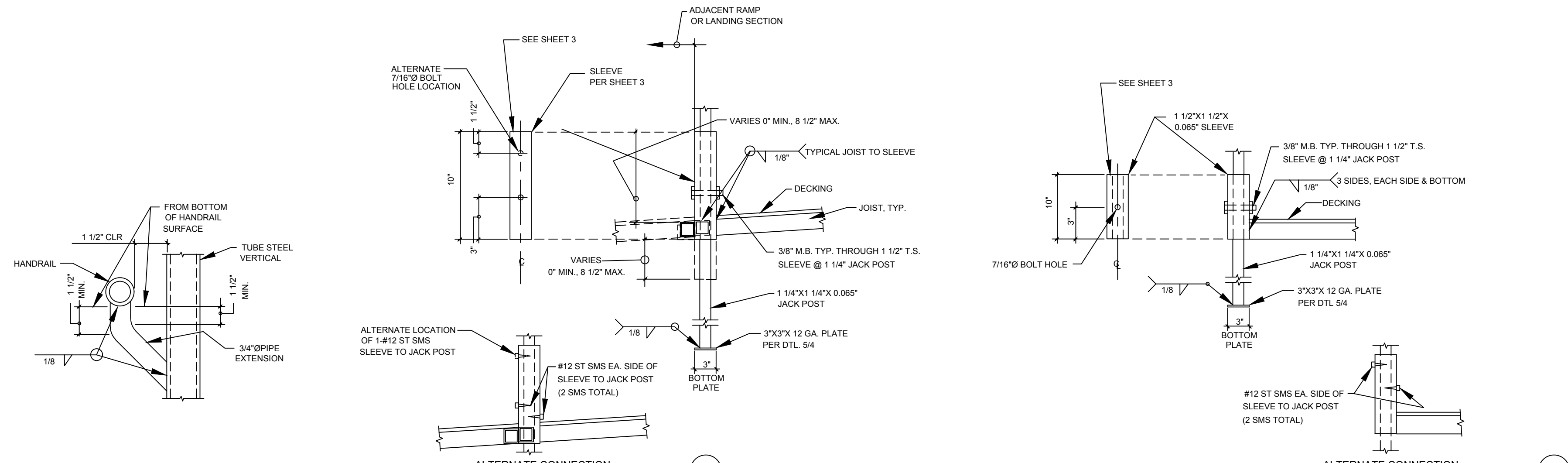

**NOTES:**

2019 CALIFORNIA BUILDING CODE (CBC)

DESIGN LOADS:  
 LIVE LOAD: 100 PSF  
 WIND LOAD: SEE SHEET 1A  
 SEISMIC: SEE SHEET 1A

HANDRAIL & GUARD RAIL LOADS:  
 500 LBS  
 2000 POINT LOAD

MATERIAL SPECIFICATIONS:  
 STEEL: ALL PLANKS, ANGLE, CHANNELS, ETC. SHALL BE ASTM A1011SS GRADE 40 (Fy = 40 KSI, MIN.)  
 ALL TUBE STEEL ASTM A-1008 CS TYPE A OR B (Fy = 40KSI)  
 ALL STEEL TO BE COATED WITH A RUST INHIBITIVE COATING  
 BOLTS: ASTM A307 COMMON BOLTS HOT DIPPED GALVANIZED W/ STAINLESS STEEL WASHERS  
 PLYWOOD OPTION: APA RATED STRUCT 1 EXTERIOR PLYWOOD  
 WELDS: ALL WELDING SHALL CONFORM TO "AMERICAN WELDING SOCIETY D-1.3-2008 FOR SHEET STEEL.  
 ELECTRODES SHALL BE E70XX.

GENERAL NOTES:  
 1) RAMPS HAVING SLOPES STEEPER THAN 1 VERTICAL TO 20 HORIZONTAL SHALL HAVE LANDINGS AT TOP AND BOTTOM AND AT LEAST ONE INTERMEDIATE LANDINGS SHALL BE PROVIDED FOR EACH 30' OF RISE. PER CBC 11B-405.7.  
 2) LOCATION OF LANDINGS:  
 LANDINGS SHALL BE PROVIDED AT TOP AND BOTTOM OF EACH RAMP. INTERMEDIATE LANDINGS SHALL BE PROVIDED AT INTERVALS NOT EXCEEDING 30 INCHES OF VERTICAL RISE AND AT EACH CHANGE OF DIRECTION. LANDINGS ARE NOT CONSIDERED IN DETERMINING THE MAXIMUM HORIZONTAL DISTANCE OF EACH RAMP.  
 NOTE: EXAMPLES OF RAMP DIMENSIONS ARE:  

SLOPE	MAX. RISE (INCHES)	MAX. HORIZONTAL PROJECTION
1:12	30	30'-0"
1:16	30	40'-0"
1:20	30	50'-0"
1:15	30	37'-6"

  
 2) SIZE OF TOP LANDINGS: TOP LANDINGS SHALL NOT BE LESS THAN 60 INCHES WIDE AND SHALL HAVE A LENGTH OF NOT LESS THAN 60 INCHES IN THE DIRECTION OF RAMP RUN. PER CBC 11B-405.7.2 AND 3.  
 3) DOORS IN ANY POSITION SHALL NOT REDUCE THE MINIMUM DIMENSION OF THE LANDING TO LESS THAN 42" AND SHALL NOT REDUCE THE REQUIRED WIDTH BY MORE THAN 3" WHEN FULLY OPENED. CBC 11B-405.7.5.  
 4) RAMPS SHALL BE CONSTRUCTED AS REQUIRED FOR STAIRWAYS.  
 5) THE SURFACE OF RAMPS SHALL BE ROUGHED OR SHALL BE OF SLIP-RESISTANT MATERIAL, TYP. FOR LANDINGS & STAIRS.  
 6) RAMPS REQUIREMENTS SHALL BE PER CBC 11B-405.  
 7) RAMPS AND STAIRWAYS USED AS EXIT SHALL CONFORM TO CBC SEC. 1009 SEC. 1010, CHAPTER 11B AND 11B-405.5.  
 8) HANDRAILS AND GUARDRAILS SHALL CONFORM TO CBC 11B-405.8 (RAMP), AND 11B-504 (STAIRS).  
 9) RAMPS SHALL CONFORM TO CBC 11B-405.  
 10) STRIKE EDGE EXTENSION THE WIDTH OF THE LANDING SHALL EXTEND 24" PAST THE STRIKE EDGE OF ANY DOOR OR GATE FOR EXTERIOR RAMPS AND 18" PAST THE STRIKE EDGE FOR INTERIOR RAMPS.  
 11) LANDING WIDTH: AT BOTTOM AND INTERMEDIATE LANDINGS, THE WIDTH SHALL BE AT LEAST THE SAME AS REQUIRED FOR RAMPS, CBC 11B-405.7.4.  
 12) THE WIDTH OF RAMPS SHALL BE AS REQUIRED PER STAIRWAYS AND EXITS, CBC 11B-405.5.  
 13) SLOPE RAMPS AND LANDINGS AS REQUIRED TO PREVENT ACCUMULATION OF WATER ON WALKING SURFACES.  
 14) ALL WORK SHALL CONFORM TO TITLE 24 CALIFORNIA CODE OF REGULATIONS TITLE 24, CCR.  
 15) SPECIAL INSPECTION IS REQUIRED FOR THE FOLLOWING WORK:  
 MATERIAL VERIFICATION  
 DSA SPECIAL INSPECTOR: CLASS 4 (ON SITE)

PRE-CHECK (PC) DOCUMENT  
 CODE: 2019 CBC  
 A SEPARATE PROJECT APPLICATION FOR CONSTRUCTION IS REQUIRED

REGISTERED PROFESSIONAL ENGINEER  
 JAMES T. SIMPSON  
 No. 3602  
 STRUCTURAL  
 STATE OF CALIFORNIA

January 7, 2021  
 DATE SIGNED

APPROVED  
 DIV. OF THE STATE ARCHITECT  
 APP: 04-119501 PC  
 REVIEWED FOR  
 SS  FLS  ACS  CG   
 DATE: 02/09/2021

DETAILS AND NOTES  
 TMP SERVICES  
 2929 KANSAS AVE  
 RIVERSIDE, CA 92507  
 PHONE: (951)213-3900  
 FAX: (951)213-3997

STATE OF CALIFORNIA  
 PC  
 -2019 CBC

DRAWN  
 CHECKED  
 DATE  
 03 FEB 2020  
 SCALE  
 JOB NO.

4A  
 12 OF 16 SHEETS

PROPRIETARY DESIGN: THIS DRAWING AND THE MATERIAL CONTAINED THEREIN ARE THE PROPERTY OF TMP SERVICES, INC. AND SHALL NOT BE REPRODUCED, COPIED OR OTHERWISE DISPOSED OF DIRECTLY OR INDIRECTLY AND SHALL NOT BE USED IN WHOLE OR IN PART TO ASSIST IN THE MAKING OF OR THE PURPOSE OF FURNISHING ANY INFORMATION FOR THE MAKING OF DRAWINGS, PRINTS, APPARATUS OR PARTS THEREOF WITHOUT THE FULL KNOWLEDGE AND CONSENT OF TMP SERVICES, INC. ALL PATENTABLE MATERIAL CONTAINED HEREIN AND ORIGINATED WITH TMP SERVICES, INC. SHALL BE THE PROPERTY OF TMP SERVICES, INC.

EXL  
 STRUCTURAL ENGINEERS, INC.  
 4691 RIVERSIDE DRIVE, SUITE 114  
 CHINO, CALIFORNIA 91710

MEMBER  
 STRUCTURAL ENGINEERS  
 ASSOCIATION OF CALIFORNIA  
 AMERICAN CONCRETE  
 INSTITUTE  
 (909) 613-0234

TMP INC 2019 STEEL SHEET 4-010



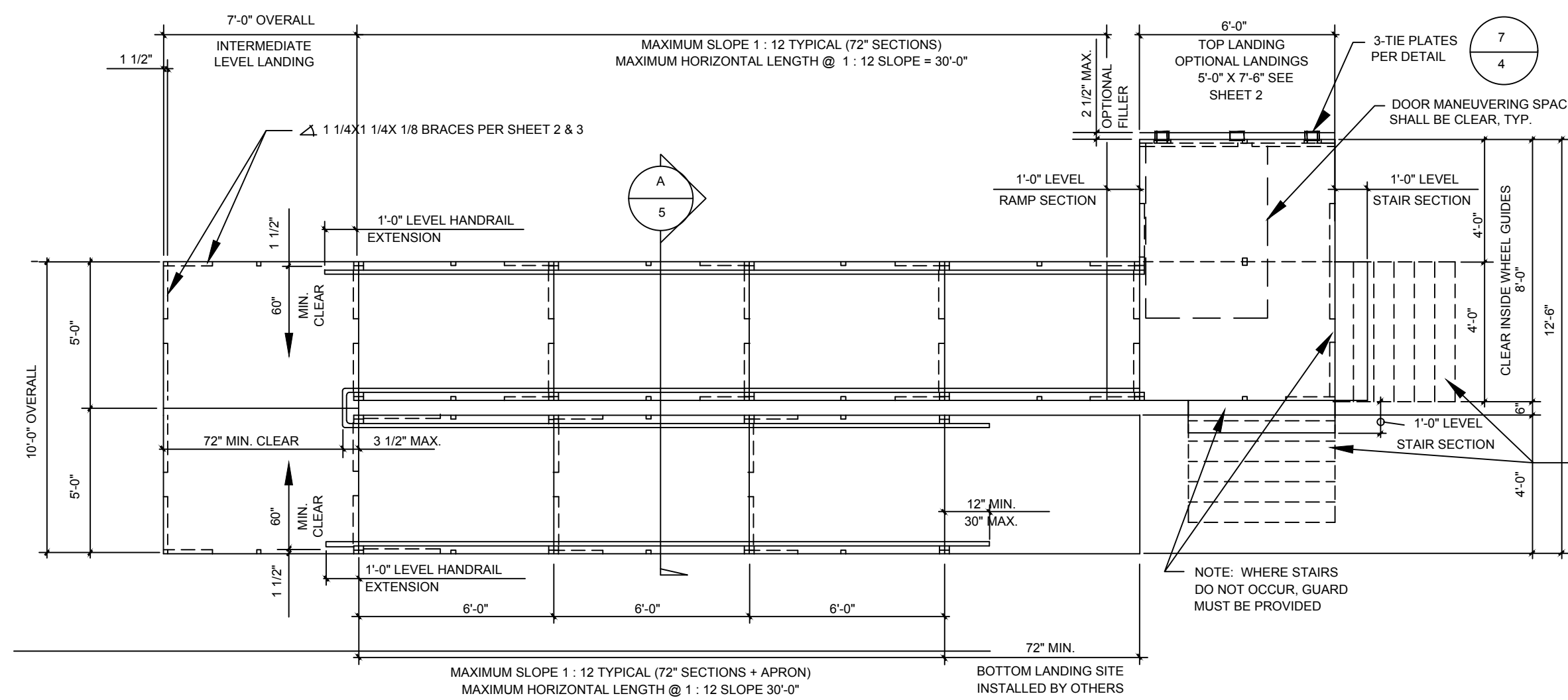

**TYPICAL PLAN VIEW OF ACCESSIBLE RAMP WITH SWITCH-BACK & PLATFORMS**

SCALE: 1/4" = 1'-0"

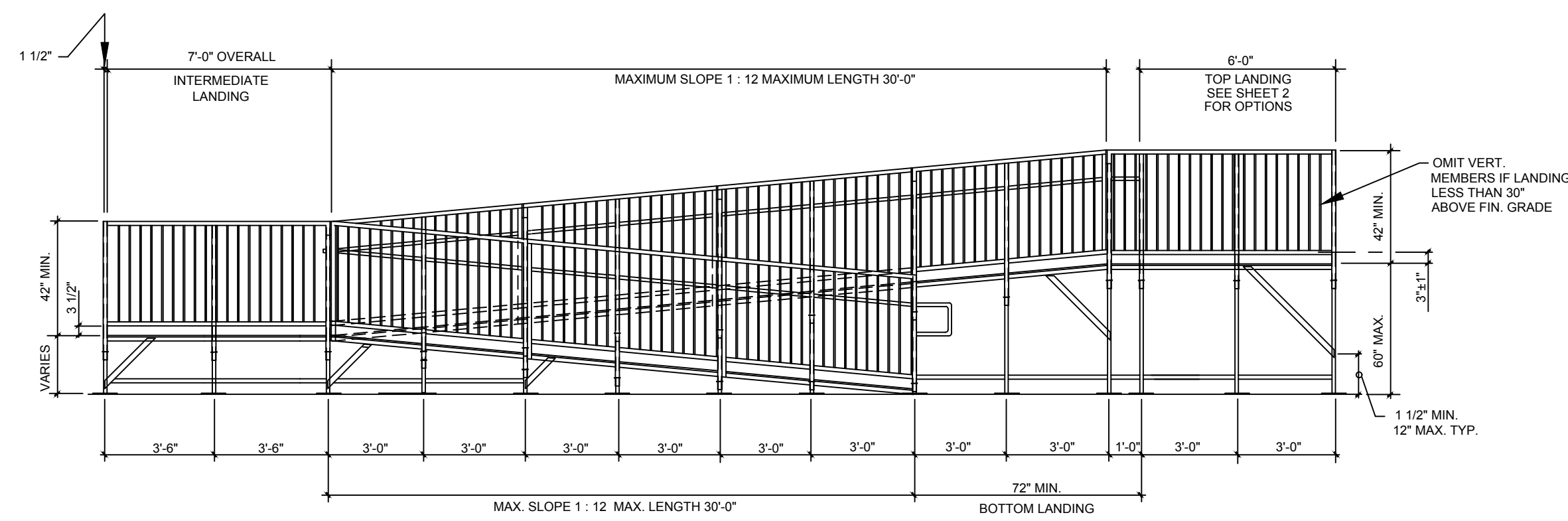

**TYPICAL ELEVATION OF ACCESSIBLE RAMP W/SWITCH-BACK RAMP**

SCALE: 1/4" = 1'-0"

NOTE: SEE SHEET 3A FOR HANDRAIL/GUARDRAIL SIZES

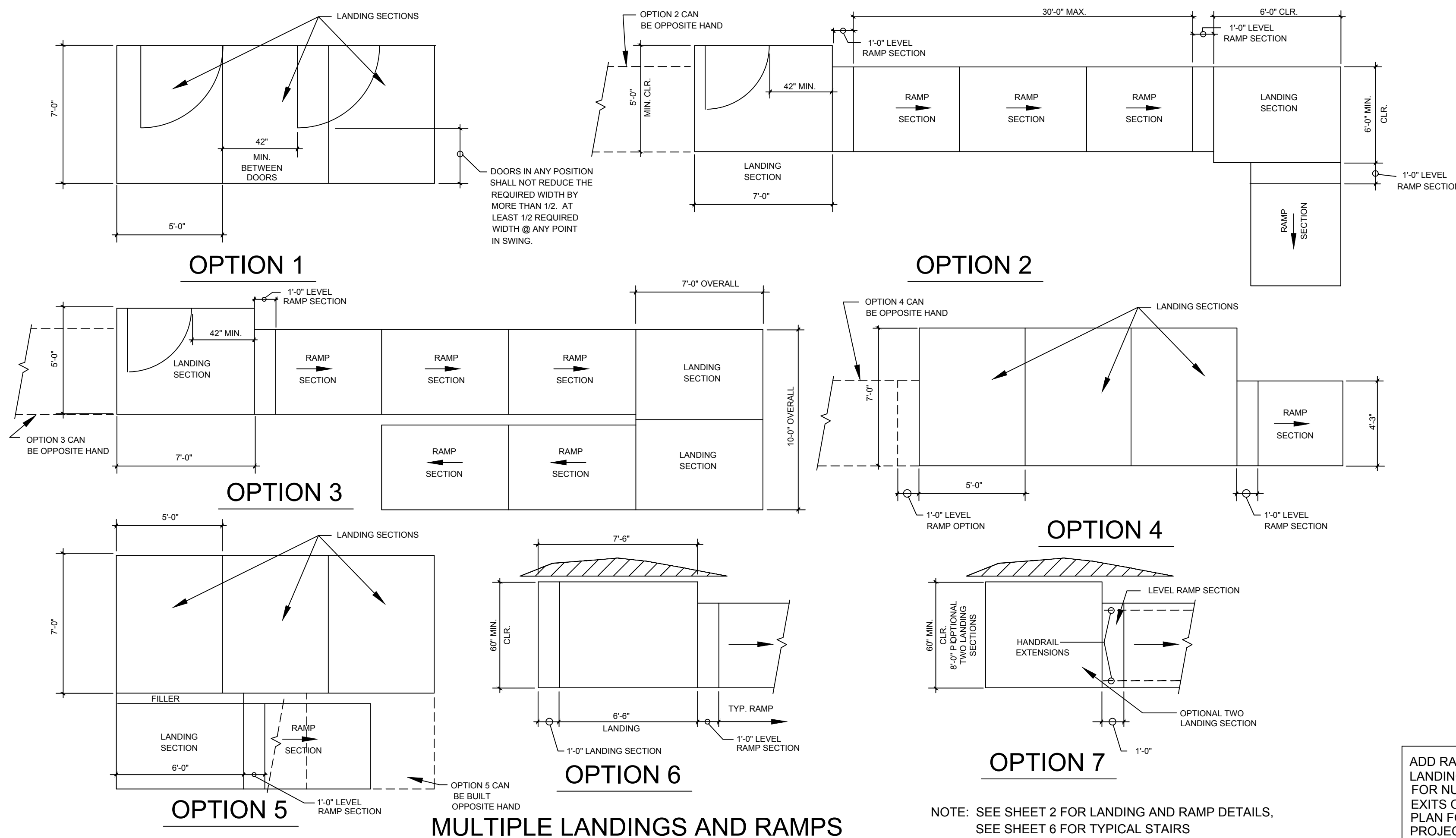

**MULTIPLE LANDINGS AND RAMPS**

NOTE: SEE SHEET 2 FOR LANDING AND RAMP DETAILS, SEE SHEET 6 FOR TYPICAL STAIRS

**TYPICAL CROSS SECTIONS**

SCALE: 1/4" = 1'-0"

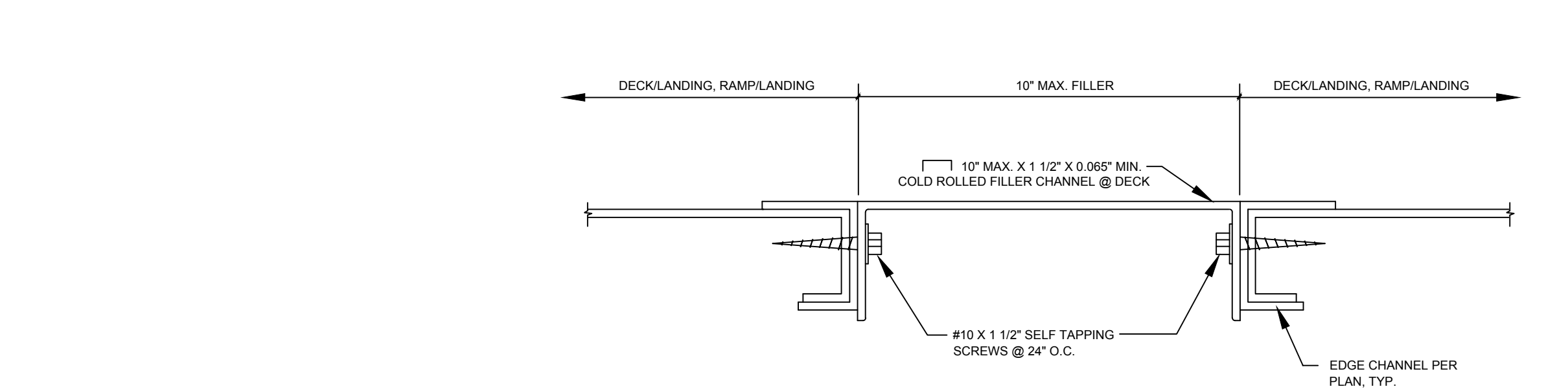

**TYPICAL DECK CROSS SECTION**

SCALE: 1/2" = 1'-0"

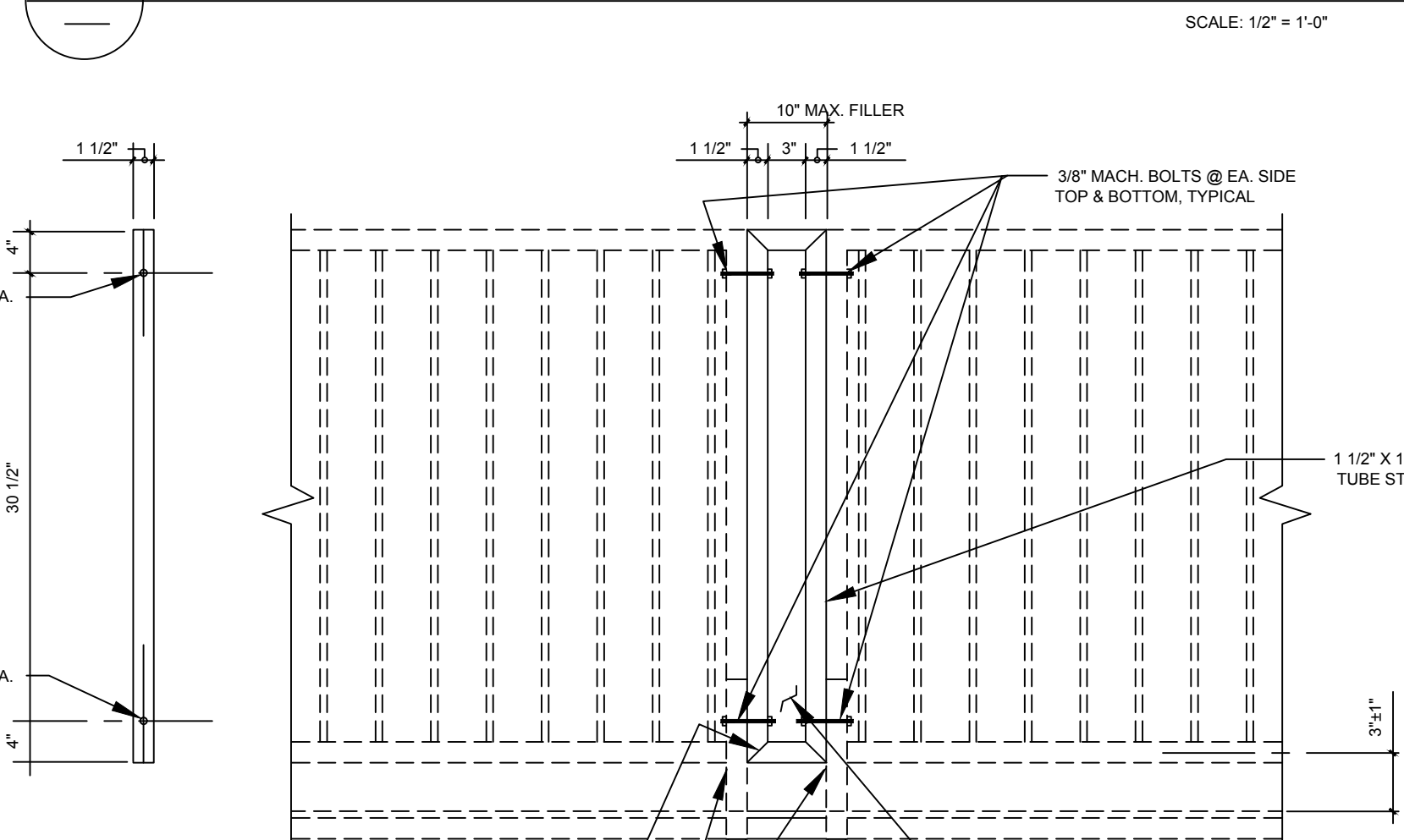

**TYPICAL GUARDRAIL FILLER**

SCALE: 3/4" = 1'-0"

PROPRIETARY DESIGN: THIS DRAWING AND THE MATERIAL CONTAINED THEREIN ARE THE PROPERTY OF TMP SERVICES, INC. AND SHALL NOT BE REPRODUCED, COPIED OR OTHERWISE DISPOSED OF DIRECTLY OR INDIRECTLY AND SHALL NOT BE USED IN WHOLE OR IN PART TO ASSIST IN THE MAKING OF OR THE PURPOSE OF FURNISHING ANY INFORMATION FOR THE MAKING OF DRAWINGS, PRINTS, APPARATUS OR PARTS THEREOF WITHOUT THE FULL KNOWLEDGE AND CONSENT OF TMP SERVICES, INC. ALL PATENTABLE MATERIAL CONTAINED HEREIN AND ORIGINATED WITH TMP SERVICES, INC. SHALL BE THE PROPERTY OF TMP SERVICES, INC.

**EXL**  
STRUCTURAL ENGINEERS, INC.  
4091 RIVERSIDE DRIVE, SUITE 114  
CHINO, CALIFORNIA 91710

MEMBER  
STRUCTURAL ENGINEERS  
ASSOCIATION OF CALIFORNIA  
AMERICAN CONCRETE  
INSTITUTE  
(909) 613-0234

ADD RAMPS, STAIRS, LANDINGS AS REQUIRED FOR NUMBER OF EXITS ON SITE PLAN FOR SPECIFIC PROJECTS.

PRE-CHECK (PC) DOCUMENT  
CODE: 2019 CBC  
A SEPARATE PROJECT  
APPLICATION FOR CONSTRUCTION  
IS REQUIRED

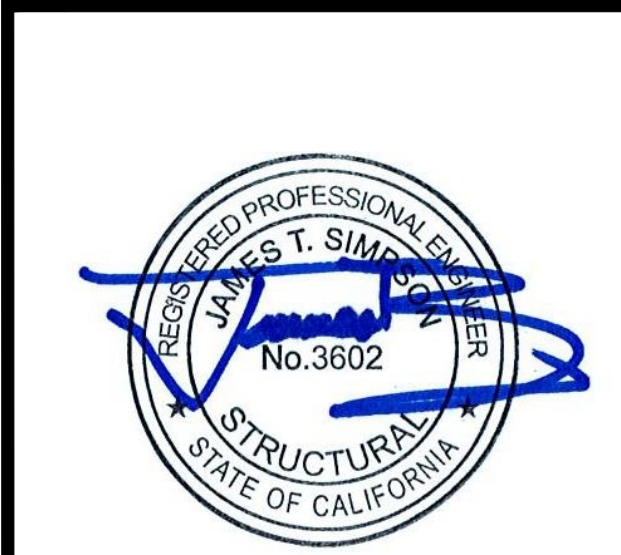

January 7, 2021  
DATE SIGNED

APPROVED  
DIV. OF THE STATE ARCHITECT  
APP: 04-119501 PC  
REVIEWED FOR  
SS  FLS  ACS  CG   
DATE: 02/09/2021

ACCESSIBLE RAMP  
SWITCHBACK DETAILS

TMP SERVICES  
2929 KANSAS AVE.  
RIVERSIDE, CA 92507  
PHONE: (951)213-3900  
FAX: (951)213-3997

STATE OF CALIFORNIA  
PC  
-2019 CBC

DSA APPROVALS

DRAWN  
CHECKED  
DATE  
03 FEB 2020  
SCALE  
JOB NO.  
**5A**  
13 OF 16 SHEETS

TMP INC 2013 STEEL SHEET PILING



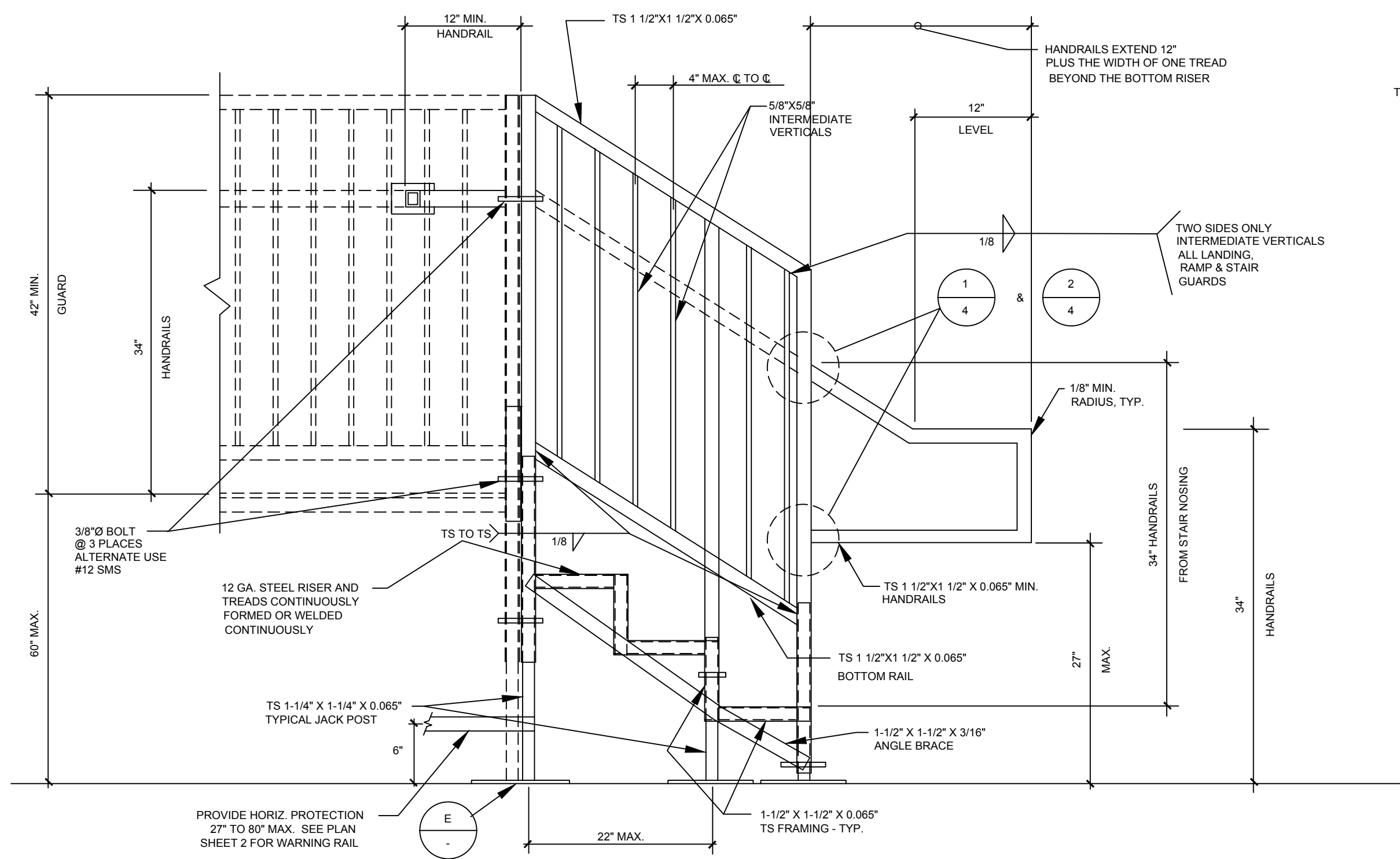

**SIDE VIEW**

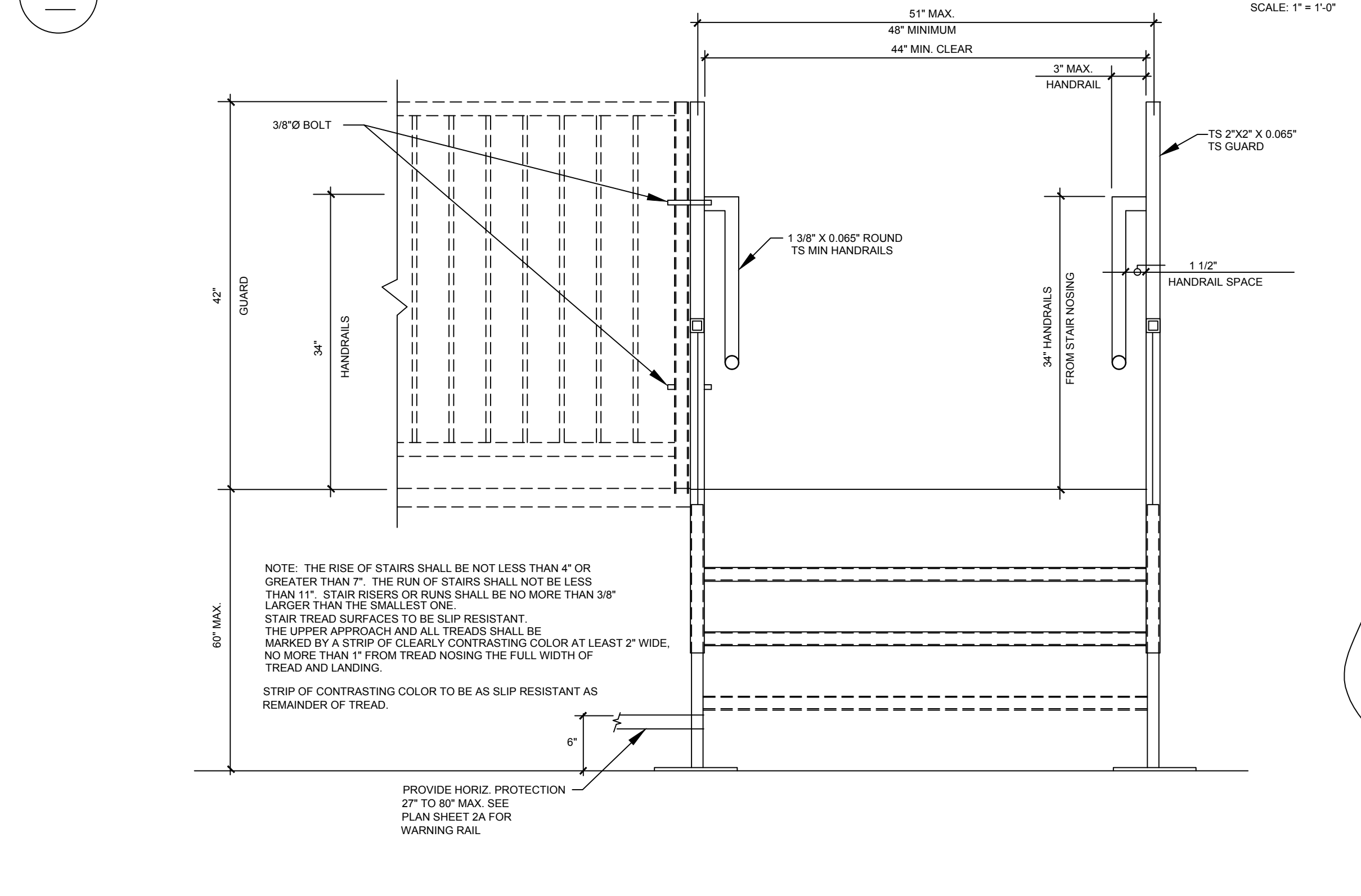

**FRONT VIEW**

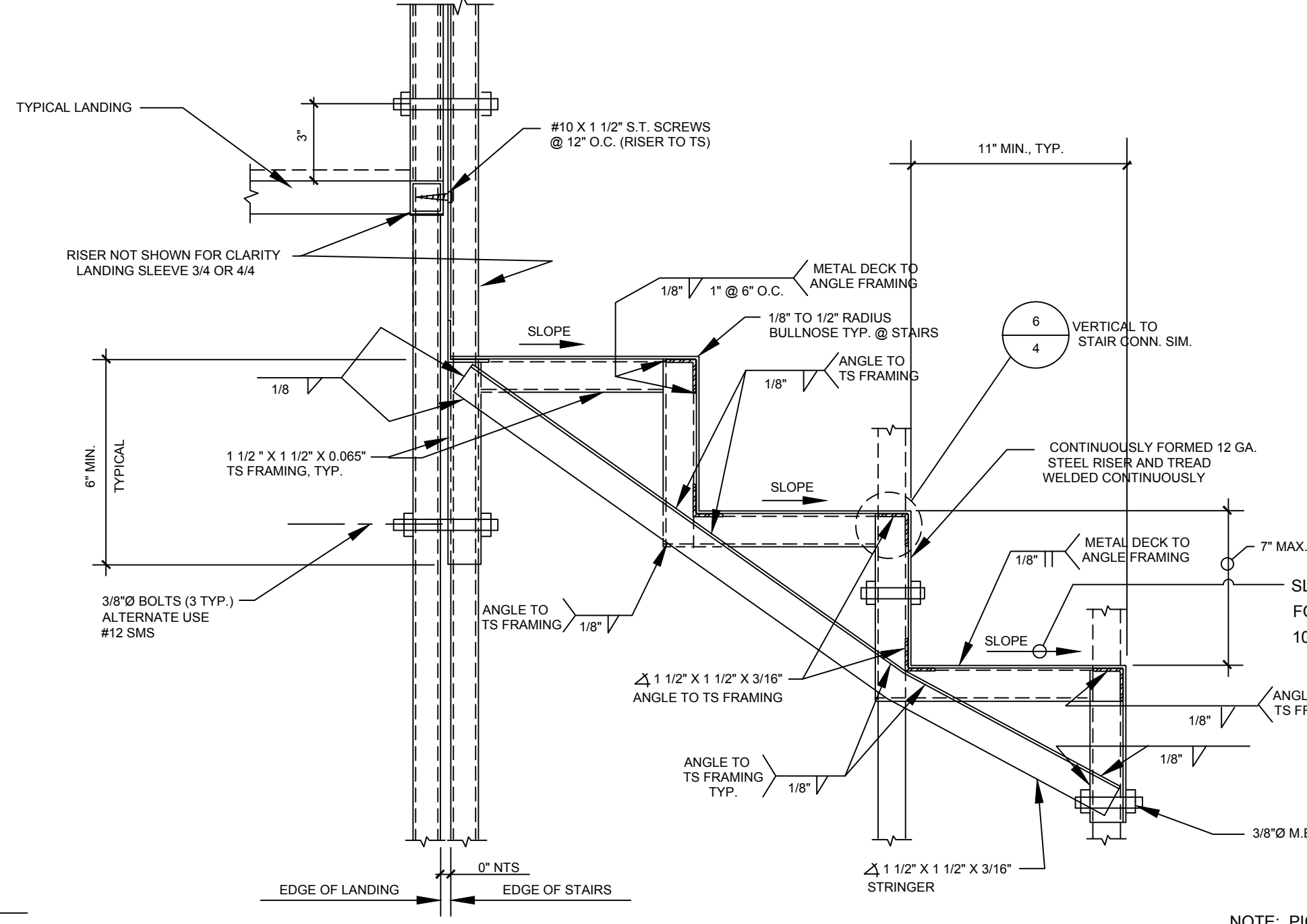

**SECTION**

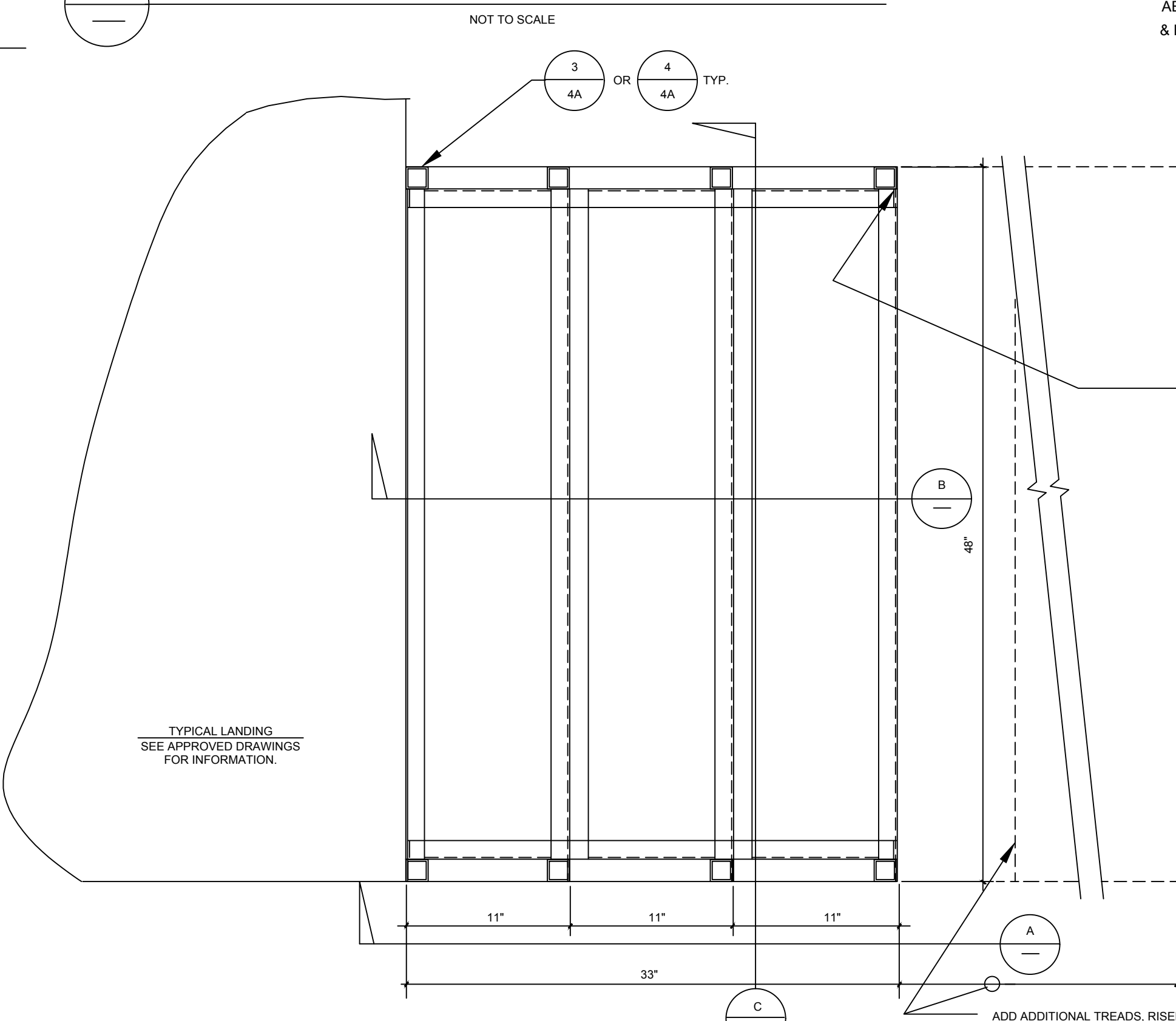

**PLAN VIEW**

NOTE: PICKETS & 42" HIGH GUARD REQUIRED FOR THRESHOLD HEIGHTS GREATER THAN 30" ABOVE FINISH GRADE. FOR THRESHOLD HEIGHTS LESS THAN 30" ABOVE FINISH GRADE, PICKETS CAN BE OMITTED & HANDRAIL WILL ACT AS GUARD.

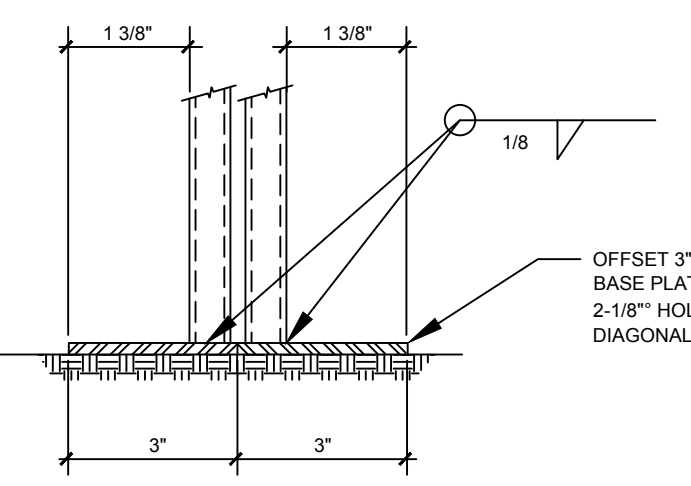

**E**

PROPRIETARY DESIGN: THIS DRAWING AND THE MATERIAL CONTAINED THEREIN ARE THE PROPERTY OF TMP SERVICES, INC. AND SHALL NOT BE REPRODUCED, COPIED OR OTHERWISE DISPOSED OF DIRECTLY OR INDIRECTLY AND SHALL NOT BE USED IN WHOLE OR IN PART TO ASSIST IN THE MAKING OF OR THE PURPOSE OF FURNISHING ANY INFORMATION FOR THE MAKING OF DRAWINGS, PRINTS, APPARATUS OR PARTS THEREOF WITHOUT THE FULL KNOWLEDGE AND CONSENT OF TMP SERVICES, INC. ALL PATENTABLE MATERIAL CONTAINED HEREIN AND ORIGINATED WITH TMP SERVICES, INC. SHALL BE THE PROPERTY OF TMP SERVICES, INC.

**EXL**  
STRUCTURAL ENGINEERS, INC.  
4091 RIVERSIDE DRIVE, SUITE 114  
CHINO, CALIFORNIA 91710

MEMBER  
STRUCTURAL ENGINEERS  
ASSOCIATION OF CALIFORNIA  
AMERICAN CONCRETE  
INSTITUTE  
(909) 613-0234

PRE-CHECK (PC) DOCUMENT  
CODE: 2019 CBC  
A SEPARATE PROJECT  
APPLICATION FOR CONSTRUCTION  
IS REQUIRED



January 7, 2021  
DATE SIGNED

APPROVED  
DIV. OF THE STATE ARCHITECT  
APP: 04-119501 PC  
REVIEWED FOR  
SS  FLS  ACS  CG   
DATE: 02/09/2021

STAIRS OPTIONAL  
TMP SERVICES  
2929 KANSAS AVE.  
RIVERSIDE, CA 92507  
PHONE: (951)213-3900  
FAX: (951)213-3997

DSA APPROVALS

SITE: \_\_\_\_\_  
STATE OF CALIFORNIA  
PC  
-2019 CBC

DRAWN  
CHECKED  
DATE  
03 FEB 2020  
SCALE  
JOB NO.

**6A**

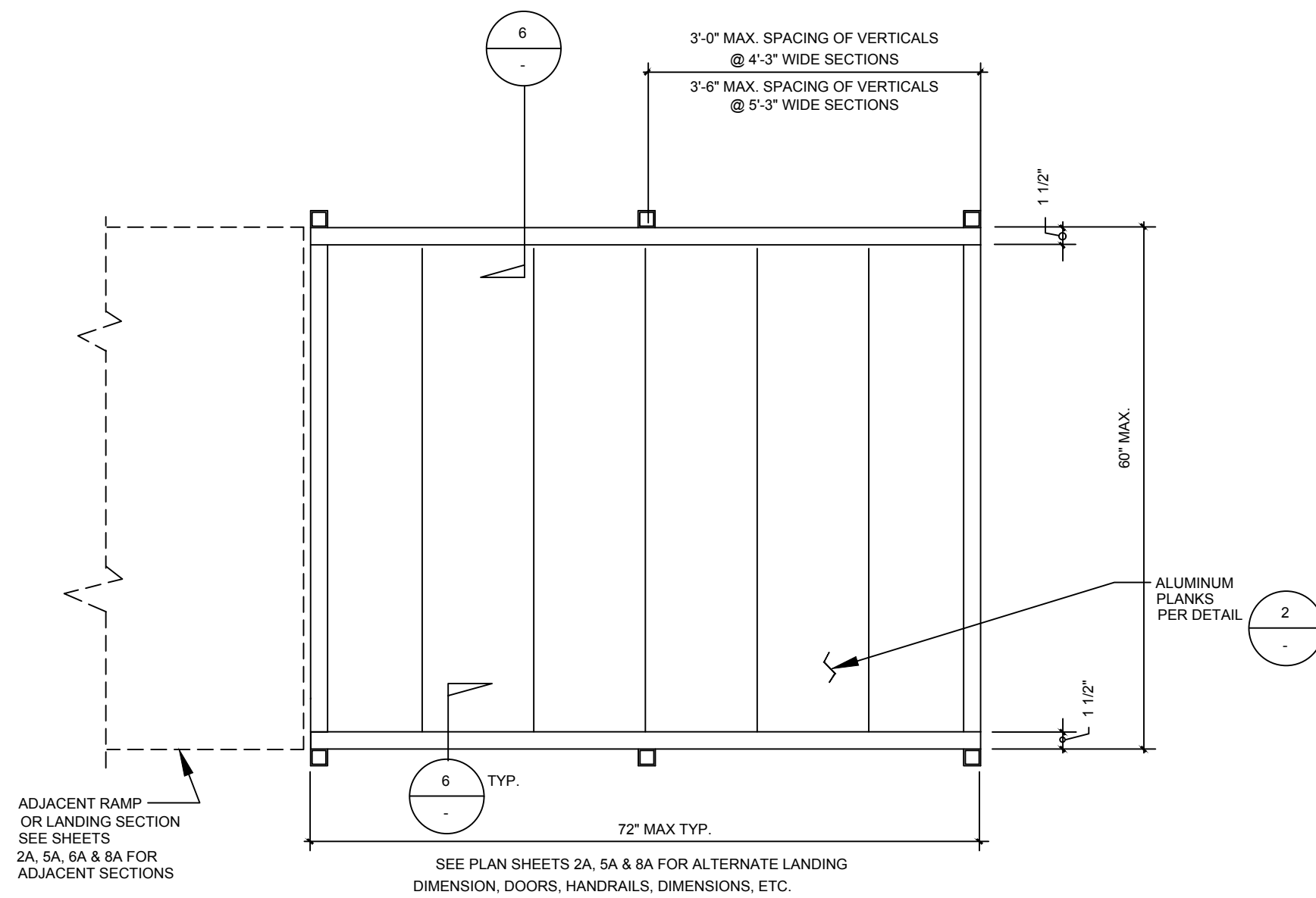

**LANDING OR RAMP SECTION** 1B

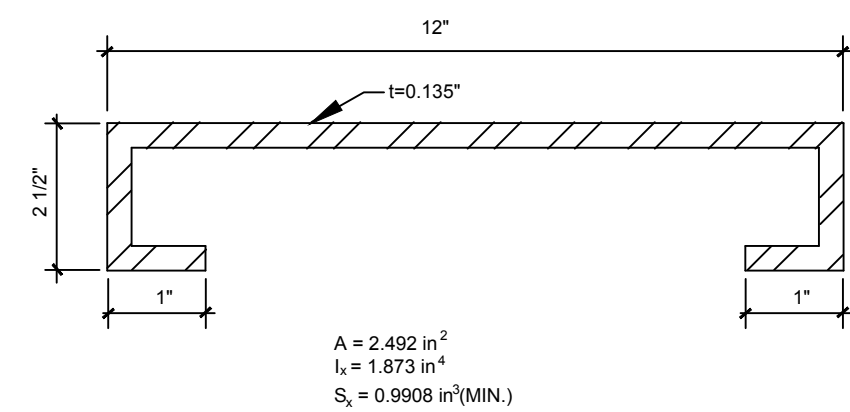

**ALUM. PLANKING** 2

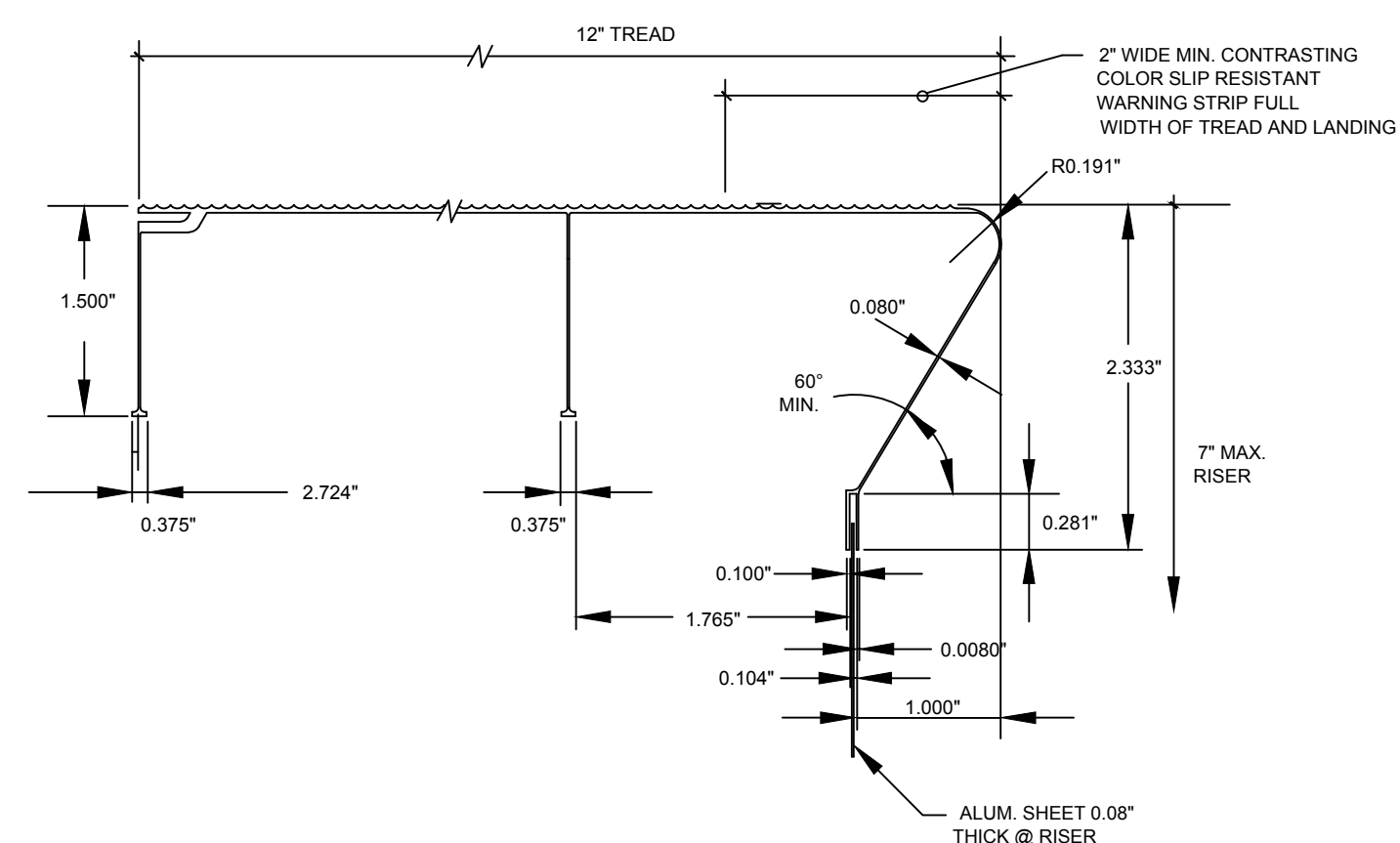

**ALUM. STAIR TREAD** 4

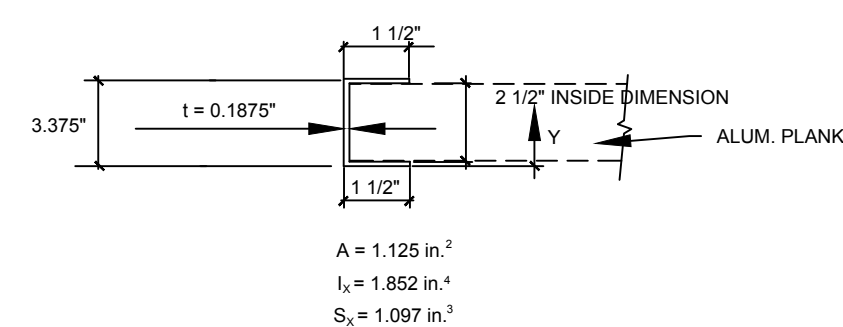

**ALUM EDGE CHANNEL @ RAMP** 6

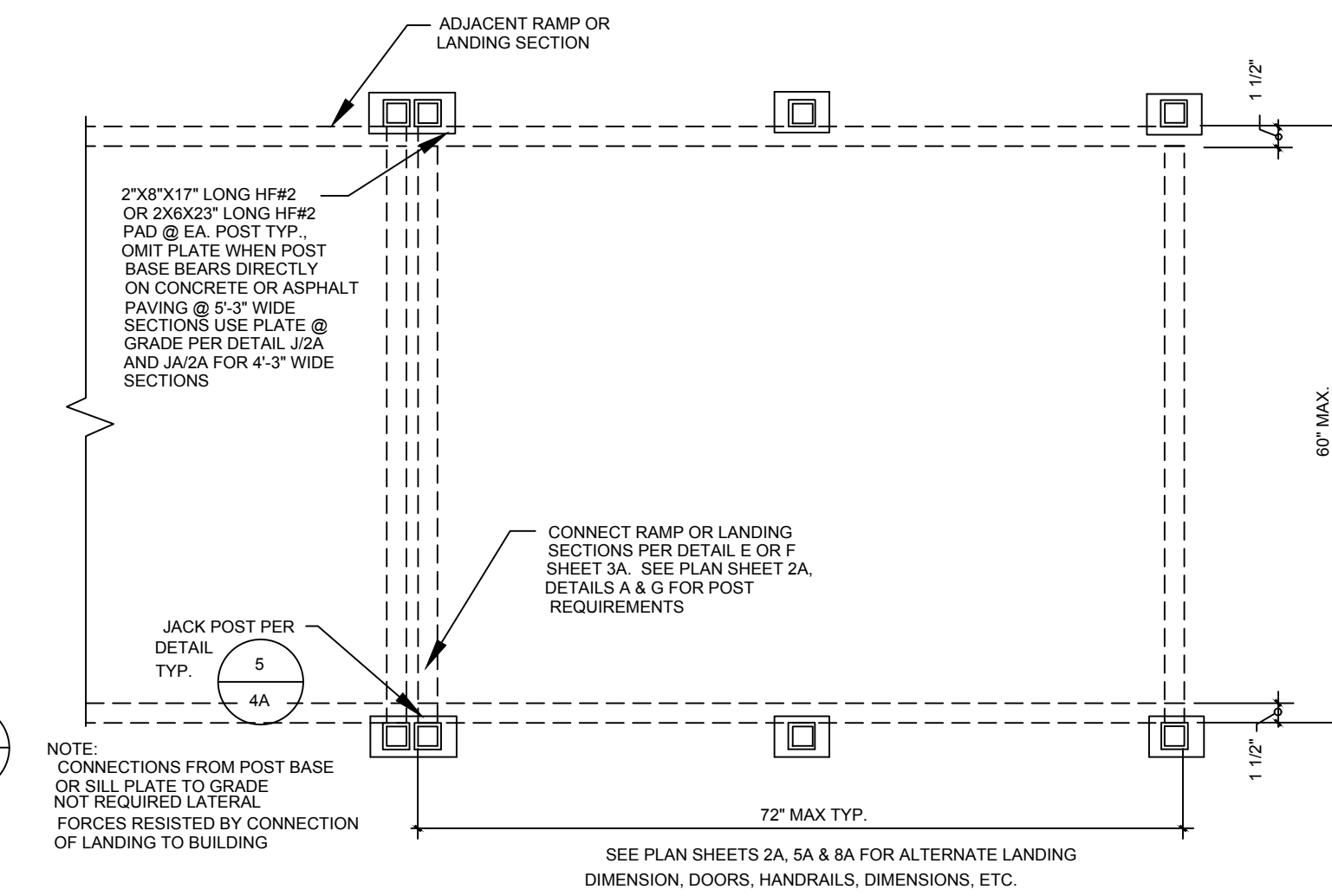

**FOOTINGS @ LANDING OR RAMP SECTION** 1A

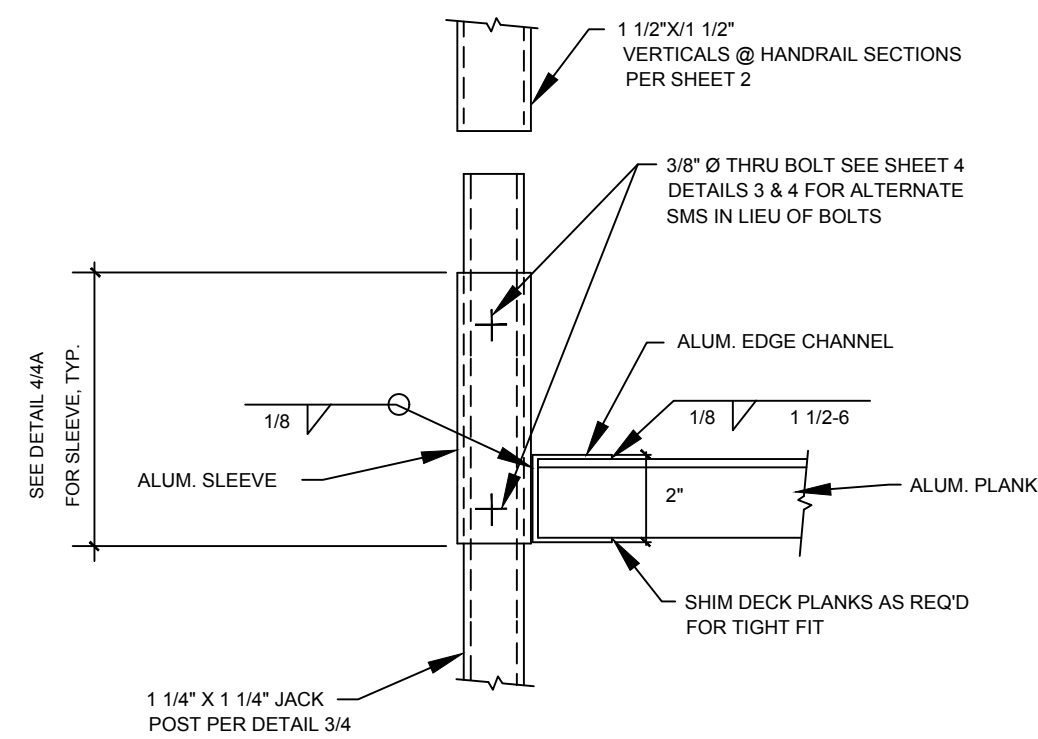

**ALUM. SLEEVE DETAIL** 3

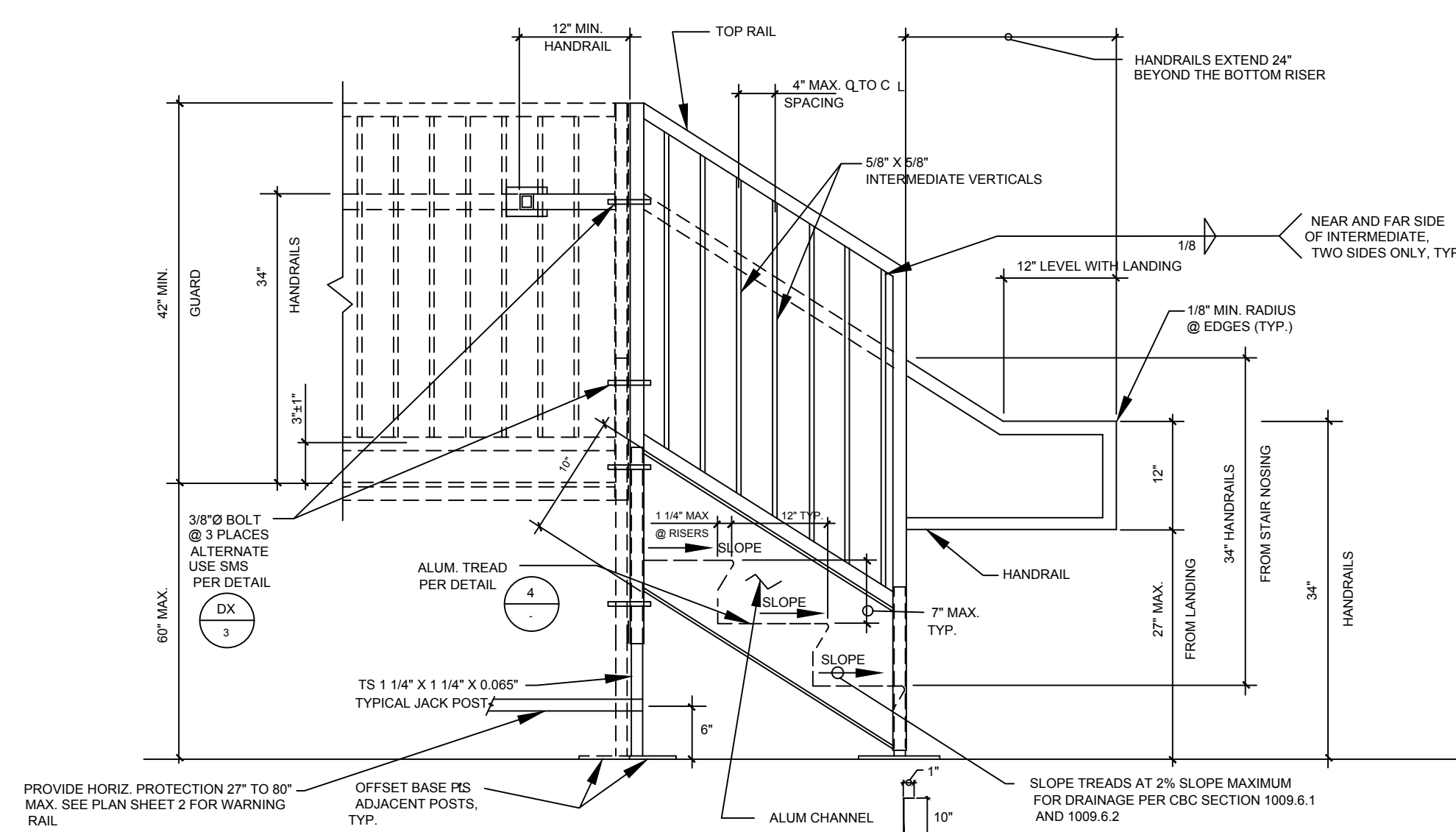

**STAIRS** 5

NOTE: PICKETS & 42" HIGH GUARD REQUIRED FOR THRESHOLD HEIGHTS GREATER THAN 30" ABOVE FINISH GRADE. FOR THRESHOLD HEIGHTS LESS THAN 30" ABOVE FINISH GRADE, PICKETS CAN BE OMITTED & HANDRAIL WILL ACT AS GUARD.

PROPRIETARY DESIGN: THIS DRAWING AND THE MATERIAL CONTAINED THEREIN ARE THE PROPERTY OF TMP SERVICES, INC. AND SHALL NOT BE REPRODUCED, COPIED OR OTHERWISE DISPOSED OF DIRECTLY OR INDIRECTLY AND SHALL NOT BE USED IN WHOLE OR IN PART TO ASSIST IN THE MAKING OF OR THE PURPOSE OF FURNISHING ANY INFORMATION FOR THE MAKING OF DRAWINGS, PRINTS, APPARATUS OR PARTS THEREOF WITHOUT THE FULL KNOWLEDGE AND CONSENT OF TMP SERVICES, INC. ALL PATENTABLE MATERIAL CONTAINED HEREIN AND ORIGINATED WITH TMP SERVICES, INC. SHALL BE THE PROPERTY OF TMP SERVICES, INC.

**EXL**  
STRUCTURAL ENGINEERS, INC.  
4091 RIVERSIDE DRIVE, SUITE 114  
CHINO, CALIFORNIA 91710

MEMBER  
STRUCTURAL ENGINEERS  
ASSOCIATION OF CALIFORNIA  
AMERICAN CONCRETE  
INSTITUTE  
(909) 613-0234

**NOTES:**  
MATERIAL SPECIFICATIONS:  
ALUMINUM:  
1 1/4" X 1 1/4" X 1/8" ANGLE 6063 T5  
2" X 1 1/2" X 1/8" CHANNEL 6063 T5  
DECK PLANKS 6063 T5  
STAR PLANKS 6063 T5  
  
BOLTS: ALUMINUM 6061-T6, 2024-T4 OR 7075-T73, ALTERNATE USE TYPE 304 STAINLESS STEEL BOLTS WITH STAINLESS STEEL WASHERS  
  
WELDS: ALL WELDING SHALL CONFORM TO "AMERICAN WELDING SOCIETY D1.2 FOR ALUMINUM". ELECTRODES SHALL BE 6356 OR 5554.  
  
SEE SHEET 4A FOR GENERAL NOTES

PRE-CHECK (PC) DOCUMENT  
CODE: 2019 CBC  
A SEPARATE PROJECT  
APPLICATION FOR CONSTRUCTION  
IS REQUIRED



January 7, 2021  
DATE SIGNED

APPROVED  
DIV. OF THE STATE ARCHITECT  
APP: 04-119501 PC  
REVIEWED FOR  
SS  FLS  ACS  CG   
DATE: 02/09/2021

ACCESSIBLE RAMP  
OPTIONAL ALUMINUM DECK

TMP SERVICES  
2929 KANSAS AVE.  
RIVERSIDE, CA 92507  
PHONE: (951) 213-3900  
FAX: (951) 213-3997

SITE: \_\_\_\_\_  
STATE OF CALIFORNIA  
PC  
-2019 CBC

DSA APPROVALS

DRAWN  
CHECKED  
DATE  
03 FEB 2020  
SCALE  
JOB NO.

**7A**

15 OF 16 SHEETS



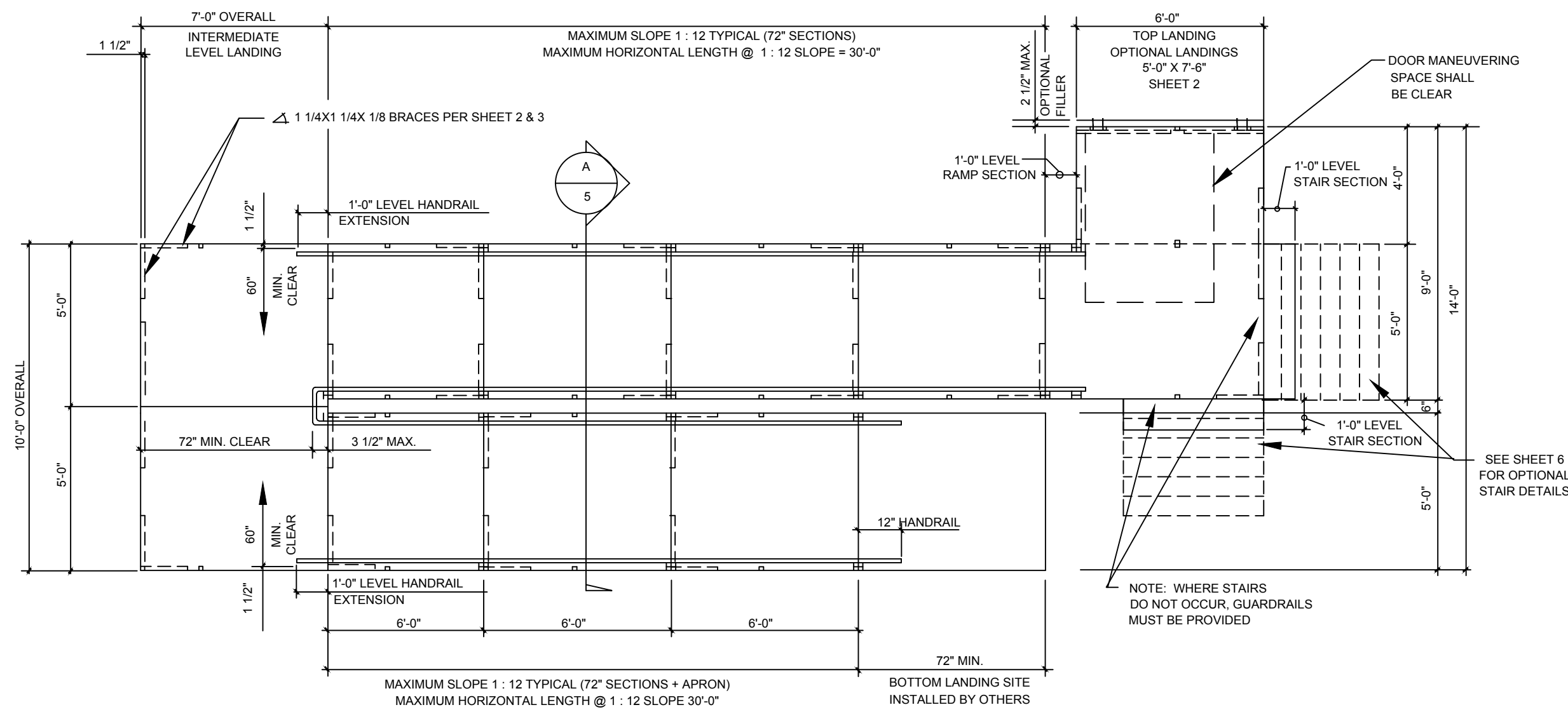

TYPICAL PLAN VIEW OF ACCESSIBLE RAMP WITH SWITCH-BACK & PLATFORMS

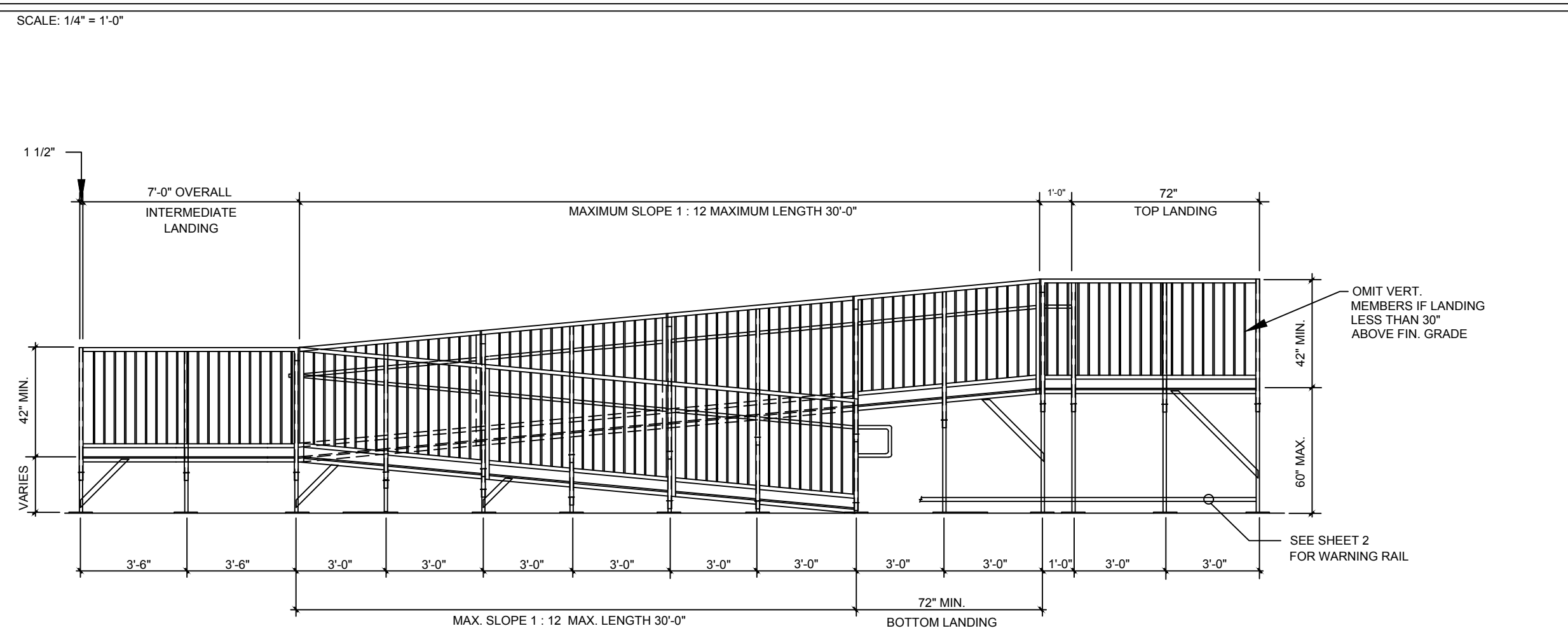

TYPICAL ELEVATION OF ACCESSIBLE RAMP W/SWITCH-BACK RAMP W/ 5'-0" WIDE RAMPS

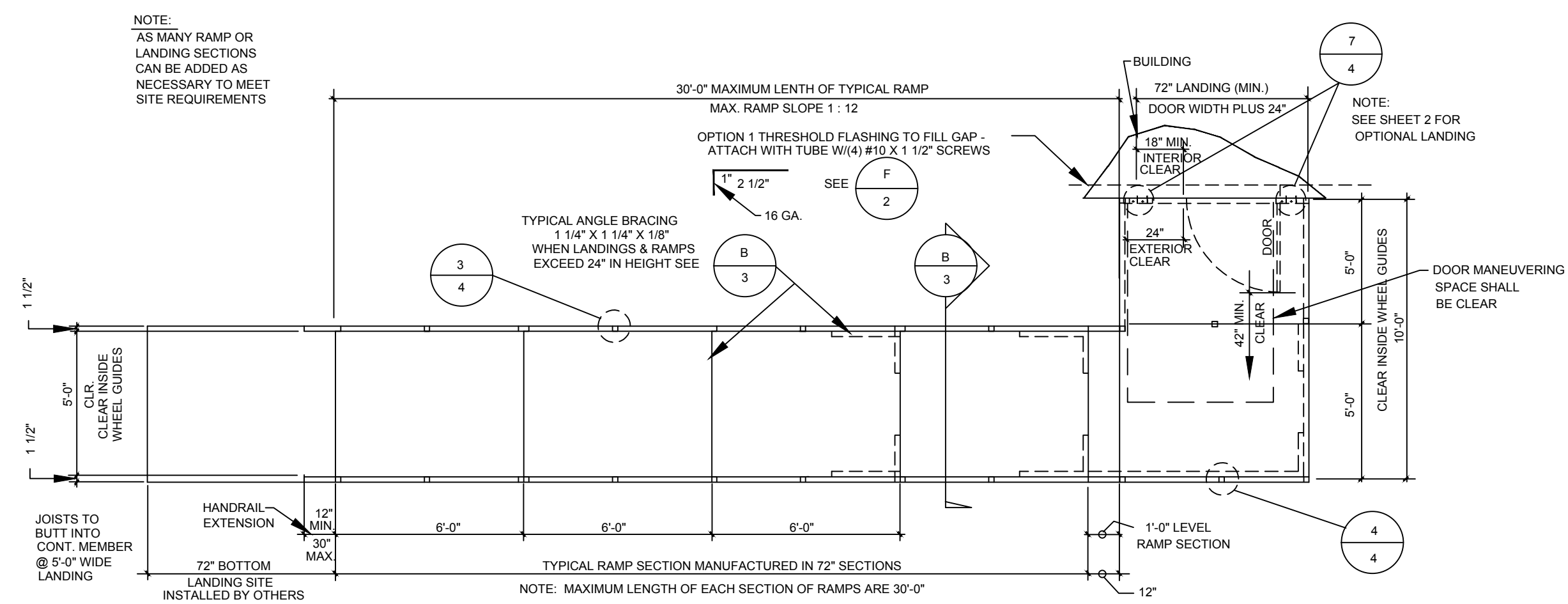

TYPICAL PLAN VIEW OF ACCESSIBLE RAMP & DECK LAYOUT

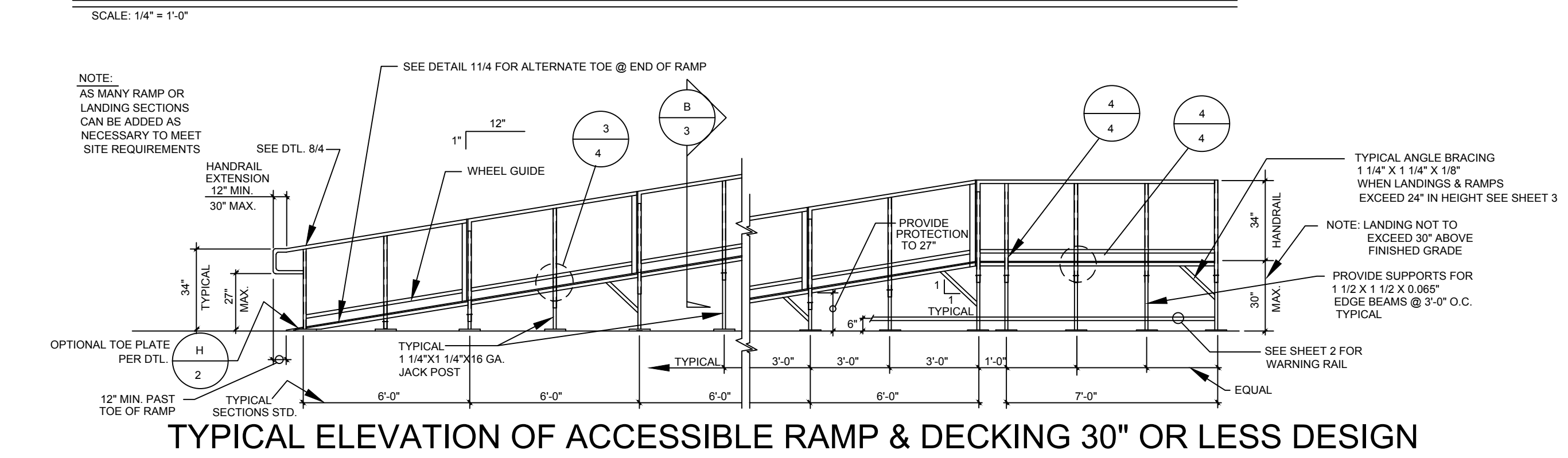

TYPICAL ELEVATION OF ACCESSIBLE RAMP & DECKING 30" OR LESS DESIGN

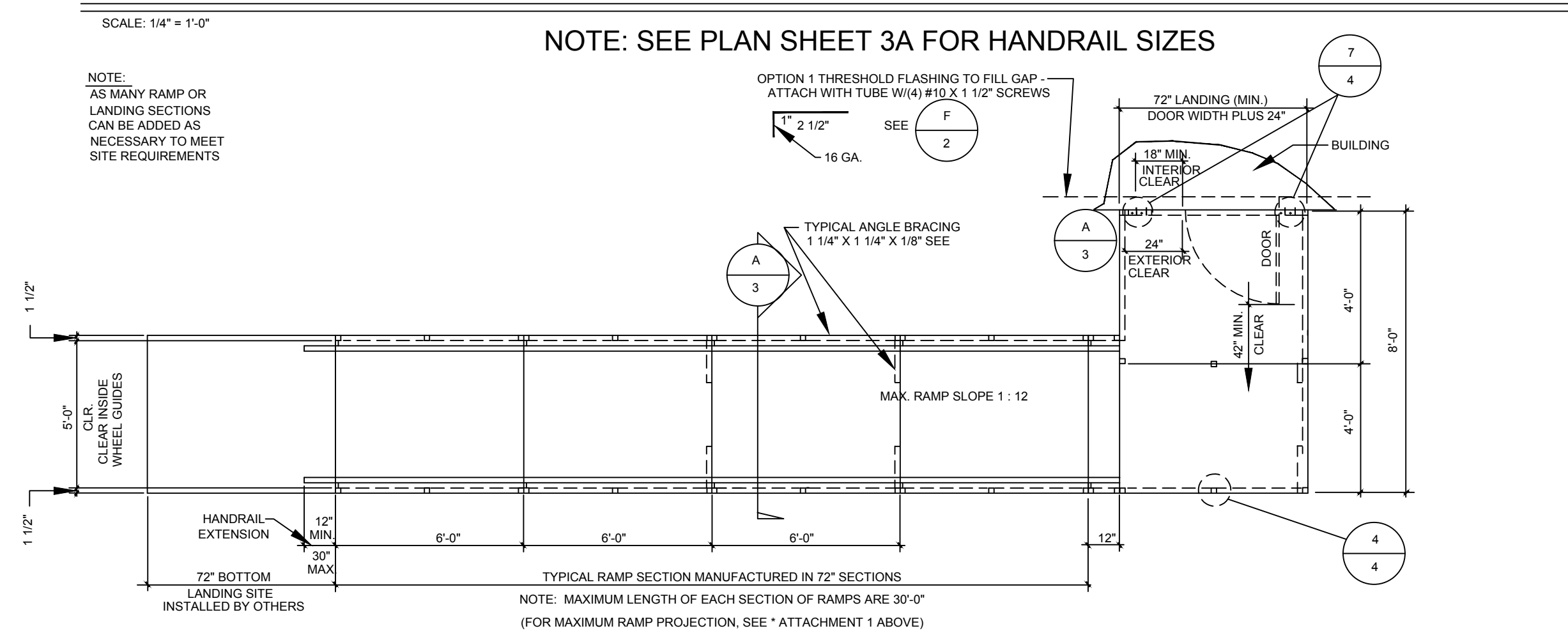

TYPICAL PLAN VIEW OF ACCESSIBLE RAMP & DECK LAYOUT OVER 30" DESIGN

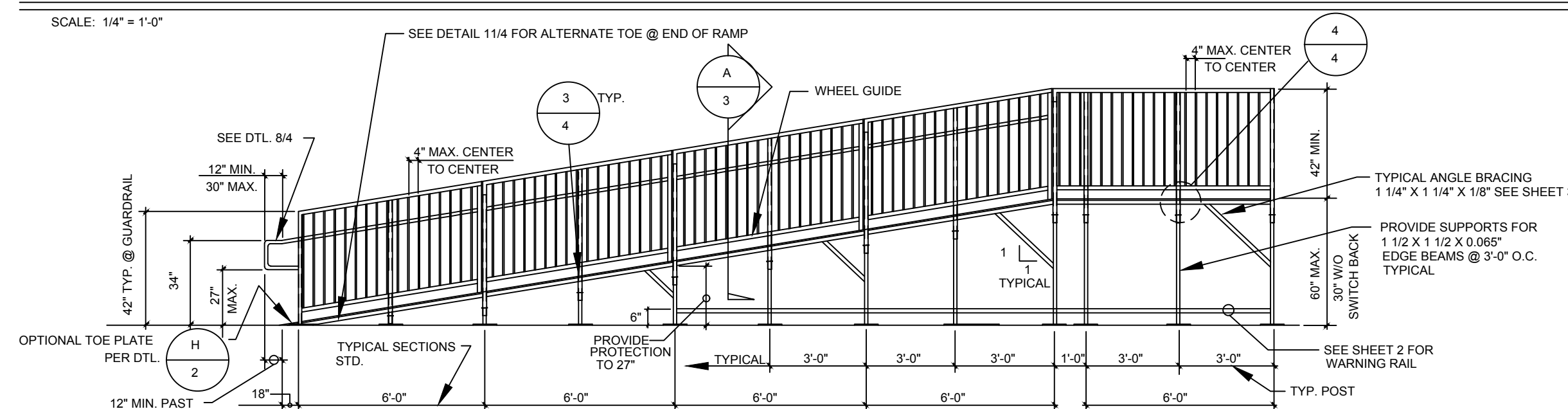

TYPICAL ELEVATION OF ACCESSIBLE RAMP & DECKING

NOTE: SEE PLAN SHEET 3A FOR HANDRAIL/GUARDRAIL SIZES

PROPRIETARY DESIGN: THIS DRAWING AND THE MATERIAL CONTAINED THEREIN ARE THE PROPERTY OF TMP SERVICES, INC. AND SHALL NOT BE REPRODUCED, COPIED OR OTHERWISE DISPOSED OF DIRECTLY OR INDIRECTLY AND SHALL NOT BE USED IN WHOLE OR IN PART TO ASSIST IN THE MAKING OF OR THE PURPOSE OF FURNISHING ANY INFORMATION FOR THE MAKING OF DRAWINGS, PRINTS, APPARATUS OR PARTS THEREOF WITHOUT THE FULL KNOWLEDGE AND CONSENT OF TMP SERVICES, INC. ALL PATENTABLE MATERIAL CONTAINED HEREIN AND ORIGINATED WITH TMP SERVICES, INC. SHALL BE THE PROPERTY OF TMP SERVICES, INC.

**EXL**  
STRUCTURAL ENGINEERS, INC.

4091 RIVERSIDE DRIVE, SUITE 114  
CHINO, CALIFORNIA 91710

MEMBER  
STRUCTURAL ENGINEERS  
ASSOCIATION OF CALIFORNIA

AMERICAN CONCRETE  
INSTITUTE

(909) 613-0234

PRE-CHECK (PC) DOCUMENT  
CODE: 2019 CBC  
A SEPARATE PROJECT  
APPLICATION FOR CONSTRUCTION  
IS REQUIRED



January 7, 2021  
DATE SIGNED

APPROVED  
DIV. OF THE STATE ARCHITECT  
APP: 04-119501 PC  
REVIEWED FOR  
SS  FLS  ACS  CG   
DATE: 02/09/2021

ACCESSIBLE RAMP  
ELEVATIONS & PLAN VIEWS

TMP SERVICES  
2929 KANSAS AVE  
RIVERSIDE, CA 92507  
PHONE: (951)213-3900  
FAX: (951)213-3997

DSA APPROVALS

SITE: \_\_\_\_\_  
STATE OF CALIFORNIA  
PC  
-2019 CBC

DRAWN  
CHECKED  
DATE  
03 FEB 2020  
SCALE  
JOB NO.

8A

16 OF 16 SHEETS





# Proposal

Rancho Murieta Community Services District

Prepared for: Amelia Wilder  
District Secretary

15160 Jackson Road  
Rancho Murieta, CA 95683



# Project quotation

Date: 6/16/2023



Brad Fallentine  
 Cell: 725-224-1899  
 Work: 209-524-0376  
 Direct: 559-832-1626

**Company:** Rancho Murieta CSD  
 15160 Jackson Road  
 Rancho Murieta, CA 95683

**Site:** 15160 Jackson Road  
 Rancho Murieta, CA 95683

**Proposal Description:** 24x60 B-2 Office

Task	Description	Qty	Unit	Unit Sales Price	Total Sales Price	Tax
<b>Building</b>						
	New Modular Building - Size 24x60 Office B-2	1	EA	\$210,772.00	\$210,772.00	Y
	Transportation from Mfg.	1	EA	\$16,461.00	\$16,461.00	Y
	Transportation (Pilot, permit, tolls)		EA			N
	Block & Level	1	EA	\$3,934.00	\$3,934.00	N
	Steel Pier Foundation Material	50	EA	\$30.04	\$1,502.00	Y
	Seismic Pier	4	EA	\$125.50	\$502.00	Y
	Running Gear - Removal	1	EA	\$1,307.00	\$1,307.00	N
	Tire Removal	1	EA	\$238.00	\$238.00	N
	Hitch Removal	1	EA	\$132.00	\$132.00	N
	Tie-down - Provide & Install	1	EA	\$2,904.00	\$2,904.00	N
	Skirting - Materials Pre-painted ship loose factory	22	EA	\$125.41	\$2,759.00	Y
	PT Framing Material for Skirting	168	LF	\$5.29	\$888.00	Y
	Skirting - Install	1	EA	\$3,105.00	\$3,105.00	N
	Labor to re-attached existing canopy to building	1	EA	\$1,030.00	\$1,030.00	N
	Dolly floors into position with Forklift	1	EA	\$1,954.00	\$1,954.00	N
<b>Ramp &amp; Step</b>						
	New ADA Ramp (N/A)		SF			Y
<b>Site Work</b>						
	Touch up Paint	1	EA	\$1,056.00	\$1,056.00	N
	Dismantle existing building & Prep for transport, includes removal of existing skirting, anchors. Includes installation of towbars, axles, and tires. Price is based upon towbars, axles and tires are underneath building and in working condition.	1	EA	\$6,950.00	\$6,950.00	N
	Reinforce structurally damaged sidewalls for transport	1	EA	\$7,868.00	\$7,868.00	N
	detach existing canopy and brace for later reinstallation	1	EA	\$1,373.00	\$1,373.00	N
	Provide forklift to dolly floors into position for transport company	1	EA	\$1,954.00	\$1,954.00	N

The quotation is good for 30 days and is limited to availability of stock on hand. Please schedule as soon as possible to secure your preferred delivery date. By signing below the Customer named below agrees to the conditions outlined in Pacific Mobile's Terms and Conditions.

Authorized Representative Signature

Date

Brad.fallentine@pacificmobile.com

# Project quotation

Date: 6/16/2023



Brad Fallentine  
Cell: 725-224-1899  
Work: 209-524-0376  
Direct: 559-832-1626

	Close-up material for dismantle	1	EA	\$825.00	\$825.00	Y
<b>General Requirements</b>						
	Engineering - (Foundation, Ramp)	1	EA	\$682.00	\$682.00	N
	Estimated Reg., License, Title Fee	1	EA	\$4,412.00	\$4,412.00	N

<b>Subtotal</b>	\$272,608.00
<b>Tax</b>	7.75%
<b>Tax Total</b>	\$18,112.45
<b>Project Total</b>	<b>\$290,720.45</b>

The quotation is good for 30 days and is limited to availability of stock on hand. Please schedule as soon as possible to secure your preferred delivery date. By signing below the Customer named below agrees to the conditions outlined in Pacific Mobile's Terms and Conditions.

\_\_\_\_\_  
Authorized Representative Signature

\_\_\_\_\_  
Date

 [Brad.falentine@pacificmobile.com](mailto:Brad.falentine@pacificmobile.com)

# Project quotation

Date: 6/16/2023



Brad Fallentine

Cell: 725-224-1899

Work: 209-524-0376

Direct: 559-832-1626

## Exceptions / Clarifications:

- Standard wages included; prevailing wages optional.
- Performance & payment bonds not included.
- Obtaining required County/City building permits, fees, and inspections not included.
- Customer site must be dry, compacted, level, and accessible by normal truck delivery.
- All costs to skate manually, crane, or forklift the building into position would be an additional cost.
- Delivery does not include any special delivery permits, pilot cars, police escorts, or flagman.
- Any special site required escorts, safety meetings, or other site related down-time would be an additional cost.
- Extra trip charges may incur if customer decides to stop work on site.
- Standard setup does not include removal of axles, tires, and tow bars
- Seismic tie-down quantities are estimated, so costs will change to the amount shown on approved engineering.
- Customer's responsible to call 811 and have underground utilities marked before building arrives on site
- Modular building does not include fire sprinklers, but no fire rating, alarm, or detectors.
- Site improvements not included (fence, landscape, sidewalk, parking, lighting, etc.). Site survey or soils testing not included.
- Preparation of modular building pad not included (Minimum of 1,500 PSF required, and +/- 6" grade difference assumed).
- Any special site testing requirements would be an additional cost.
- All utility connections to modular building are not included. (Electrical, water, sewer, etc.)
- All low voltage wiring, devises, panels, and monitoring not included.
- Site security, temporary toilets, or garbage dumpsters not included.
- Proper site drainage or SWPPP plan not included.
- ADA aluminum ramping and steps included.
- Ramping quoted assumes a grade difference of 36" from door threshold to ramp entrance, and final transition to grade will be the customer responsibility.
- Proposal includes all ramped doors at 36" above grade, and final transition to grade will be the customer responsibility.
- Roof gutters and covered entrances not included, but optional.
- Refer to attached floor plan & elevations for further clarification.
- Pricing good for 30-days

## • **New Building**

### Warranty:

- (2) Year Pacific Mobile Warranty, (5) Year HVAC Limited Warranty

### Payment Terms:

- Invoices due upon receipt.
- 35% Due upon signed contract, payment must be received to reserve production time.
- 55% Due when completed at factory, payment must be received prior to delivery.
- 8% Due upon initial punch list walk-through.
- 2% Due upon final completion.

## **Used Building**

### Warranty:

- 90 Day Limited Warranty

### Payment Terms:

- Invoices due upon receipt.
- 80% Invoiced upon signed contract, payment before delivery to site.
- 20% Due upon completion, payment must be received prior to occupancy.

UNIT #

# 24' X 60' MOBILE OFFICE WITH RESTROOM



This drawing is the property of Pacific Mobile Structures, Inc. and may not be duplicated without approval. Actual features may vary due to available inventory.

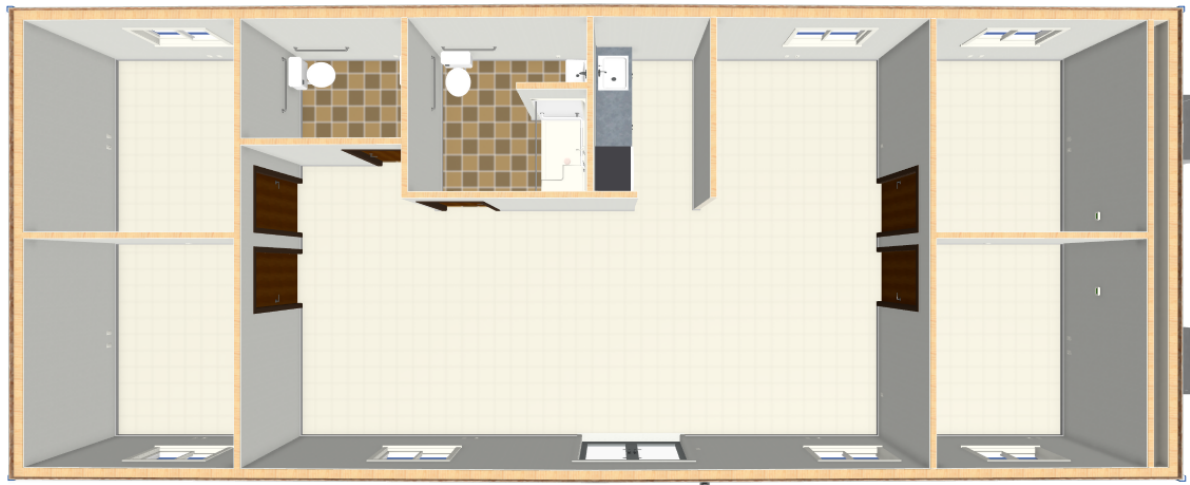
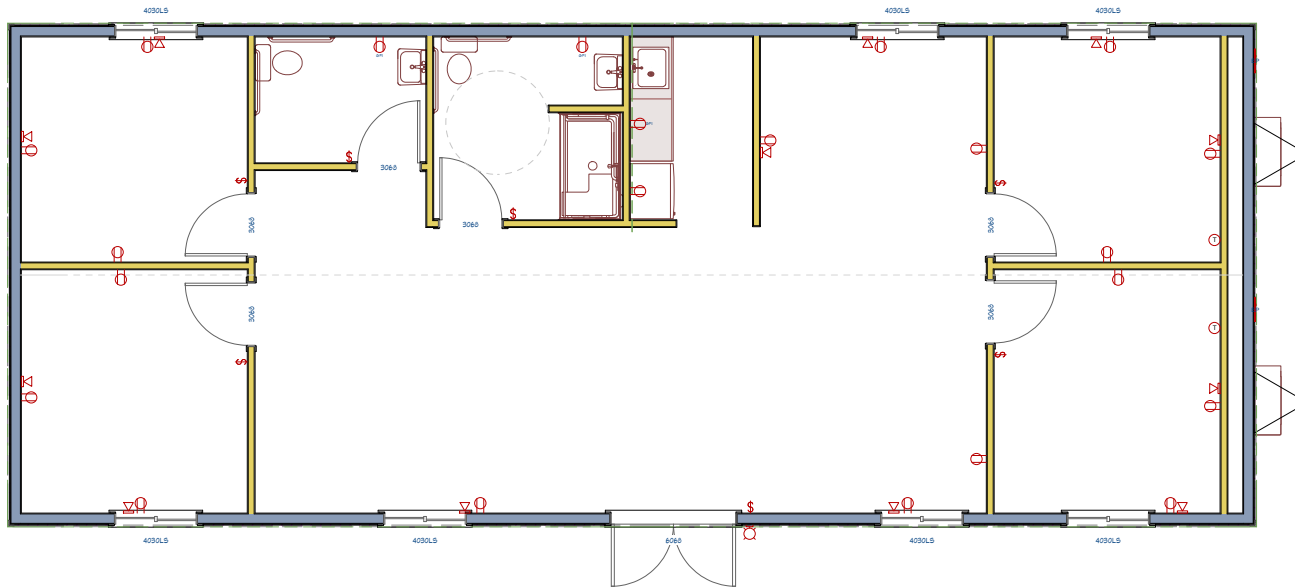

## FEATURES

- Outrigger Chassis w/hitch
- VCT Flooring w/4" vinyl base
- Vinyl wrapped interior wall covering
- 8' suspended ceiling
- 2x4 troffer lights
- Endwall HVAC w/ducted supply Plenum wall ducted return
- White EPDM roof covering
- LP SmartPanel siding  
Grey siding / Blue trim
- 4030 Horizontal sliding windows
- 6070 Storefront exterior door w/closer and deadbolt
- 3068 Prefinished interior doors w/Timely frame and passage

### LEGEND

- Panel Box
- Porch Light
- Thermostat
- Duplex Outlet
- Light Switch
- Perm. Interior wall
- Temp. Interior wall
- Empty data box

Scope of Work Specific to <b>Rancho Murieta CSD 24x60 Office with Restrooms</b>		
<b>BID REQUIREMENTS</b>	<b>PMSI</b>	<b>CLIENT</b>
Provide Proposal, specification and Scope of work	X	
Project Insurance	X	
Performance and Payment Bond	N/A	N/A
<b>PRE-CONSTRUCTION</b>	<b>PMSI</b>	<b>CLIENT</b>
Pre-construction schedule	X	X
Working hours 7:00- 5:00 (Monday-Friday, excluding Holidays)	X	
Prevailing Wages	X	
Temp Power		X
Temp Water		X
<b>PERMITS AND PROCEDURES</b>	<b>PMSI</b>	<b>CLIENT</b>
All required building permits and inspections		X
Applying for building permits, and paying fees		X
Transportation permits and pilot cars	X	
Application for Plumbing and Electrical Permits on Site		X
Excavation Permits (site needs graded and crushed rock installed to achieve 2000psf)		X
<b>SITE WORK</b>	<b>PMSI</b>	<b>CLIENT</b>
By Customer		X
<b>SITE PREPARATION</b>	<b>PMSI</b>	<b>CLIENT</b>
Site accessible by truck, free of obstacles, no overhead obstructions		X
Layout for Foundation (Building Corners and FF Elevation)		X
Access/Driveway with Gravel Base		X
Proper site drainage or SWPPP plan		X
Final grade site		X
All site improvements (landscaping, fencing, parking, sidewalks, etc.)		X
Site survey and soils report, if required		X
Site security		X

<b>FOUNDATION</b>	<b>PMSI</b>	<b>CLIENT</b>
Foundation Design	X	
Have underground utilities marked before building arrives on-site		X
Above grade steel pier foundation with seismic piers	X	
Matching building skirt, venting per code, and access door	X	
<b>TEMPORARY SITE FACILITIES</b>	<b>PMSI</b>	<b>CLIENT</b>
Temporary construction office on Site	N/A	
Portable toilets (If needed)		X
Temp fencing (If needed)		X
Temp storage or lay-down areas		X
<b>BUILDING ENGINEERING AND DESIGN</b>	<b>PMSI</b>	<b>CLIENT</b>
Engineered building plans	X	
Engineered foundation plans	X	
Engineered step & ramp plans		X
Security, alarm, computer, phone systems (if Required)		X
<b>MODULAR BUILDING</b>	<b>PMSI</b>	<b>CLIENT</b>
Modular building per floor plan and specifications	X	
Fire Sprinkler system, or fire-ratings	N/A	N/A
Interior Work (Walls/Ceiling/Floor)	X	
Exterior close-up includes required touch-up painting	X	
Building access (Ramp, landing, and steps)		X
Toe end of ramp transition		X
Pre-Finished 6' Base Cabinet with countertop and 25" x 22" S.S. Bowl Sink	X	
Upper Cabinets - N/A		X
All office furniture, equipment, and appliances (Optional)		X
Covered entrances (Existing) Set building to match entryway	X	X
<b>MODULE INSTALLATION</b>	<b>PMSI</b>	<b>CLIENT</b>
Building pad preparation		X
Deliver module sections to site	X	
Truck set modular sections	X	
Install modular building with finished floor level @ existing Ramp	X	

Remove axles, tires, and hitch (Store underneath building)	X	
Make structural connections between modular sections	X	
<b>ELECTRICAL</b>	<b>PMSI</b>	<b>CLIENT</b>
Extend electrical service to modular building subpanels		X
Connect modular subpanels to main distribution panel		X
Provide and install meter and service to building		X
Connect electrical crossovers between modular building sections	X	
<b>DATA SYSTEMS (IF REQUIRED)</b>	<b>PMSI</b>	<b>CLIENT</b>
Devices, wiring, panels, monitoring		X
Security, alarm, computer, phone systems		X
Connect to outside source		X
Dedicated Telephone Lines		X
Empty j-boxes in walls with pull strings to attic space for future use	X	
<b>PLUMBING</b>	<b>PMSI</b>	<b>CLIENT</b>
Extend water & sewer lines to modular building		X
Flush water system, and final water & sewer connections		X
HVAC condensate lines		X
Install water heater and vent per code	X	
Recirculation system if required		X
Hose bibs		X
All horizontal waste lines below modular floor		X
<b>HVAC SYSTEM</b>	<b>PMSI</b>	<b>CLIENT</b>
Supply and install HVAC system	X	
Internal modline duct crossovers	X	
Programmable thermostats	X	
Fiberglass ducting with 2x2 lay-in registers	X	
<b>CLARIFICATIONS</b>		
All work is based on being performed concurrently with ongoing site activities.		
Refer to attached drawings		
Ramping quoted assumes a grade difference of 36" between door threshold & ramp entry		
Assumed to have 20' clearance on all 4-building sides, unless otherwise noted		

Any special site testing requirements would be an additional cost
Project delays after signed contract may cause increase in labor & material pricing
Any special site requirements, meetings, or other related down-time would be extra cost
Pricing good for 30-Days



**BUILDING SPECIFICATIONS:**

Project Information:

Building size:	24x60	Wind load:	115 MPH, Exp. C
Square footage:	1440	Floor load:	50#
Occupancy:	B	Roof load:	20#
Const. type:	B2-Office	Roof slope:	¼" per foot
Seismic zone:	4	WUI zone:	No
Climate zone:	9	Sprinkler:	No
Foundation:	Temporary	State Appr:	CA

Code Compliance and Applicable Standards:

2022 California Building Code (CBC)  
2022 California Electric Code (CEC)  
2022 California Mechanical Code (CMC)  
202 California Plumbing Code (CPC)  
2022 California Energy Code & CBC Chapter 11B Accessibility  
2022 CBC for ADA ramp access to building

**BUILDING SPECIFICATIONS:**

**Size: 24 x 60 Description: Rancho Murieta**

<u>COMPONENT</u>	<u>SUB-COMPONENT</u>	<u>DESCRIPTION</u>	<u>QUANTITY</u>
FRAME			
8'/8'/8'	OUTRIGGER 2.00	Chassis Basement 12' X 60' - 12" X 11.8# I-Beam OR/CM/MC	
	AXLES	Quad Axle (4 Brake Axles)	1.00
	AXLES	Five Axle (5 Brake Axles) RRs	1.00
FLOOR			
	JOIST	2 X 8 @ 16" O/C 50#floor load	
	DECKING	3/4" T&G Plywood	
	INSULATION	R-19 Unfaced	
	COVERING	Floor Tile VCT - 1/8" X 12" X 12"	
	MISC	Bottom Board Mobile-Flex	
EXTERIOR WALL			
	STUDS	2 X 6 Ext. Wall Framing	
	SIDING	Smart Panel - 3/8" - 8" O/C Grooves - W/House Wrap	
	COVERING	1/2" Vinyl Covered Gypsum 8' Tall (Exterior Wall)	
	INSULATION	R-19 Kraft (Exterior Wall)	
INTERIOR WALL			
	STUDS	2 X 4 Wall Framing - 8' Tall	
	STUDS	Upgrade to Plumbing Wall	
	INSULATION	none provided	
	COVERING	4' FRP Wainscot RR PER CODE	
	COVERING	1/2" Vinyl Covered Gypsum 8' Tall	
	COLUMNS	Roof Support Column - Concealed	

**Size: 24 x 60 Description: Rancho Murieta**

<u>COMPONENT</u>	<u>SUB-COMPONENT</u>	<u>DESCRIPTION</u>	<u>QUANTITY</u>
COVE BASE			
	COVE BASE	Wall Base Vinyl 4" THROUGH OUT	
ROOF			
	JOIST	2 X 10 20#COMPLEX 1/4 12"	
	MATE BEAM	Modline Strap	
	MATE BEAM	Wood Beam - 48" - 4-Layer (Struct 1)	
	INSULATION	R-30 Unfaced (W/ Support Netting)	
	DECKING	1/2" Drywall	
	DECKING	1/2" Wood Decking (Roof)	
	COVERING	EPDM .045 - White	
	CEILING	2 X 4 - T-Grid - Mineral Fiber #769A 7"10 AFF	
WINDOW			
	BLINDS	Mini-Blind	7.00
	WINDOW 4030 - VINYL	4030 - H/S - Dual Glazed - Vinyl Frame - Clear Low E	7.00
EXTERIOR DOOR			
Low E)	DOOR 1.00	72X84 - Storefront Dbl - Med Style W/ Pull & Push (Dual Glazed -	
	MISC	Lite Kit - 24 X 30 - (Exterior Door)	1.00
INTERIOR DOOR			
	DOOR	36X80 Legacy Oak - Hollow Core - W/ Timely Jamb	7.00
	LOCKSET	Privacy - Tell Grade 3 - Lever RR	2.00
	LOCKSET	Passage - Tell Grade 3 - Lever	5.00

**Size: 24 x 60 Description: Rancho Murieta**

<u>COMPONENT</u>	<u>SUB-COMPONENT</u>	<u>DESCRIPTION</u>	<u>QUANTITY</u>
ELECTRICAL	PANEL	Nema 3R, External, 125 Amp Single Phase	2.00
	RACEWAY	Flex W/ Ground	
	LIGHT	Dome Light 11" LED	2.00
	EXTERIOR LIGHTS	Exterior 12w LED With Photo Control	1.00
	SWITCH	Switch Sensor Dimming	4.00
	SWITCH	15-Amp - Single OVER RIDE CEILING SENSOR	1.00
	SWITCH	Occupancy Sensor Wall Mount (Single Relay)	3.00
	SWITCH	Occupancy Sensor Ceiling Mount (Single Relay)	1.00
	RECEPTACLE	20A - GFCI Duplex	4.00
	RECEPTACLE	20A - WR GFCI Protected W/ While In Use Cover	1.00
	RECEPTACLE	20A - GFCI Duplex - Dedicated FRIDGE / MICROWAVE	2.00
	RECEPTACLE	20A - Duplex	27.00
	PHONE/DATA	6X6 Nema 3R Entrance Box	1.00
	PHONE/DATA	4X4 J-Box W/ Mud Ring & 3/4" Conduit	12.00
PLUMBING	PIPE	Copper Plumbing Drop	
	WATER CLOSET	Water Closet - ADA - Low Flow - Elongated	2.00
	LAVATORIES	Lavatory - Wall Hung	2.00
	SHOWERS	Shower ADA - 60"	2.00
	KITCHEN SINKS	25" X 22" S.S. Single Bowl Sink	1.00
	FLOOR DRAIN	Floor Drain W/ Drip Primer	2.00

**Size: 24 x 60 Description: Rancho Murieta**

<u>COMPONENT</u>	<u>SUB-COMPONENT</u>	<u>DESCRIPTION</u>	<u>QUANTITY</u>
PLUMBING			
	WATER HEATERS	40-Gallon - Electric Water Heater	1.00
	ACCESSORIES	Toilet Paper Dispenser	2.00
	ACCESSORIES	Grab-Bar Set	2.00
	ACCESSORIES	Mirror - 24" X 36" - W/Clips	2.00
	MISC	Ice Maker Valve Box	1.00
	MISC	In-Line Strainer	1.00
	MISC	Restroom Sign	2.00
HVAC			
stat	H/P - WALL MOUNT 2.00	3.0-Ton - 5-KW Heat Strip - 1P - Bard, Eubank or Equal w/pgm t-	
	CRV'S & ECONOMIZERS	Economizer For H/P End Mount	2.00
	DUCT	Fiberglass / Flex - Supply Air Duct	
	DUCT	Fiberglass / Flex Return Air Duct	
	EXHAUST FANS	70 CFM - Ceiling Mount	1.00
	EXHAUST FANS	140 CFM - Ceiling Mtd W/ Humidistat	2.00
	MISC	Plenum Wall	
	MISC	Smoke Duct Detector	2.00
FURNISHINGS			
	CABINETS	Standard Laminate Countertop	6.00
	CABINETS	Prefinished - Base Cabinet NO UPPERS	6.00



# RELENTLESS, CUSTOMER-FIRST COMMITMENT

## Large Mobile Office Fleet & Modular Construction Services

### Who We Are

As a family-owned company since 1983, our approach to business can be summed up in one word: Relationships – With our employees, our business partners, and especially our customers. With over 38 years of experience, we provide exceptional mobile office space and provide cost-effective modular construction services.

### What We Do

For Pacific Mobile Structures, there isn't a project too small or too big for our team. We have a rental fleet of 3.8 MM square feet for fast delivery of small 8x20 mobile offices and containers, but we also provide time saving, large-scale modular construction solutions for various applications - up to 75,000 square feet - through our design-build modular construction services.

### Pre-Engineered or Custom Designed

- Storage Containers
- Ground-Level Office Containers
- Mobile Offices
- Restroom & Shower Facilities
- Sales & Retail Offices
- Breakroom & Conference Space
- Relocatable Classrooms
- Smart Green Classrooms
- Permanent Modular Construction
- Administrative & Corporate Office Buildings
- Medical Clinics
- Assembly & Institutional



MOBILE OFFICES

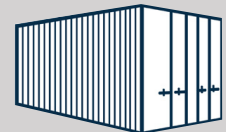

CONTAINERS



CLASSROOMS



MODULAR

## What Sets Us Apart

### EXPERIENCE

- Smart, personable staff with an average of **15 years** or more of experience in the construction and modular industries.
- We handle everything from building design to site work to installation, utilities, and more.
- More than **20 years** of fulfilling cooperative purchasing contracts, including GSA, BuyBoard, KCDA, TIPS, CMAS,

### QUALITY

- We set the highest standard of quality in the industry.
- **95%** of our mobile office deliveries experience zero service requests in the **first 30-days**.
- We exclusively provide the award winning Smart Academic Green Environment (SAGE) Classroom.

### FLEXIBILITY

- A rental fleet of **3.5 MM** square feet with 195 fully customizable floor plans and furniture options.
- Flexible pricing, financing, and payment terms. Plus, we pro-rate invoices to date of return.
- Custom modular gives customers the flexibility they need to choose the design that best fits their needs.

### DEDICATION

- **87%** of our business is repeat and referral.
- We guarantee your building for two years - **twice the industry standard**.
- In-house service department and construction crews.

## Our Locations

### Northwest Region

#### Corporate Headquarters

P.O. Box 1404 / 1554 Bishop Rd.  
Chehalis, WA 98532  
(800) 225-6539

#### Boise Branch

5305 W Diamond  
Boise, ID 83705  
(208) 362-6090

#### Chehalis Branch

113 Nalley Rd.  
Chehalis, WA 98532  
(360) 748-0121

#### Pasco Branch

3300 C East A Street  
Pasco, WA 99301  
(509) 543-9255

#### Portland Branch

13970 Fir Street  
Oregon City, OR 97045  
(503) 722-2998

#### Seattle Branch

13806 45th AVE NE  
Marysville, WA 98271  
(360) 658-6364

#### Spokane Branch

10920 West Sunset Highway  
Airway Heights, WA 99001  
(509) 543-9255

### California Region

#### Modesto Branch

4375 Farm Supply Drive  
Ceres, CA 95307  
(209) 524-9128  
CA License Number: 261942

#### Riverside Branch

26414 Murrieta Rd.  
Menifee, CA 92585  
(951) 784-8990  
CA License Number: 261942

#### San Diego Branch

7710 Paseo De La Fuente  
San Diego, CA 92154  
(619) 759-6330  
CA License Number: 261942

### Arizona Region

#### Phoenix Branch

700 E Southern Ave  
Mesa, AZ 85204  
(800) 225-6539

### Texas Region

#### San Antonio/Austin Branch

Dorado Bluffs Road  
San Marcos, TX 78666  
(800) 225-6539

#### Freeport Studios

525 County Road 330  
Freeport, TX 77541  
(877) 477-0060

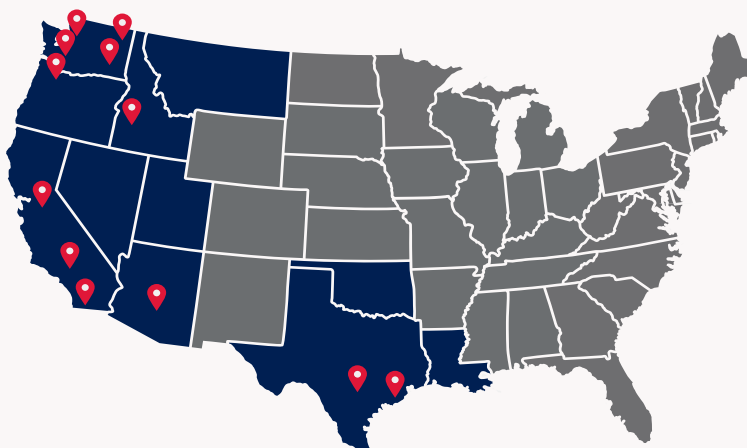

**100%** 100% Full Turnkey Construction



Furniture Packages



**50%** Construction Schedules Reduced Up to 50%



**24 HR** 24hr Service Response Time



Guaranteed On-Time Delivery and Pickup



# CUSTOMER FIRST, ALWAYS

---

Get to Know  
Pacific Mobile

**PACIFIC**  
**MOBILE STRUCTURES**



# A RELENTLESS CUSTOMER-FIRST COMMITMENT

---



## Buildings on Your Site, at Your Service

Whenever you need more space on your site, think Pacific Mobile Structures. Space that's temporary, or permanent. From a small office to a multi-story complex encompassing tens of thousands of square feet. Space to work, to learn, to serve, to worship, or for any other purpose.

We rent, build, and sell modular and mobile structures in a way that's totally unique in our industry. With an all-hands, customer-first commitment that makes it fast and easy to get the space you need.



### **Staff that knows their stuff.**

Across our team, we've worked in every industry and have the expertise and experience to put your space to work quickly, with knowledge of site development, utility connections, and building codes.

**Personal attention, deep resources.** Staffing through our regional offices gives you a personal representative who knows you and knows your local market, but we share our pooled know-how across all of our locations.

**Invested in relationships.** Family owned, we're not pressured to cut corners or compromise on service to please shareholders. Our long-term, unwavering commitment to customers comes through in everything we do.

Our unwavering commitment to you is reflected in every detail – where it shows, and where it doesn't.



Whether your space needs are temporary or permanent, you can count on Pacific Mobile to deliver.



## SITE SERVICES

When it's time to set a structure on-site, our in-house service crews are experts at what they do and share Pacific Mobile's customer-first values. They're known in the industry for their ability to work with challenging sites. After installation, you'll have the services of a fully staffed service department backed by a significant maintenance budget to uphold Pacific Mobile's consistent, high-quality standards.

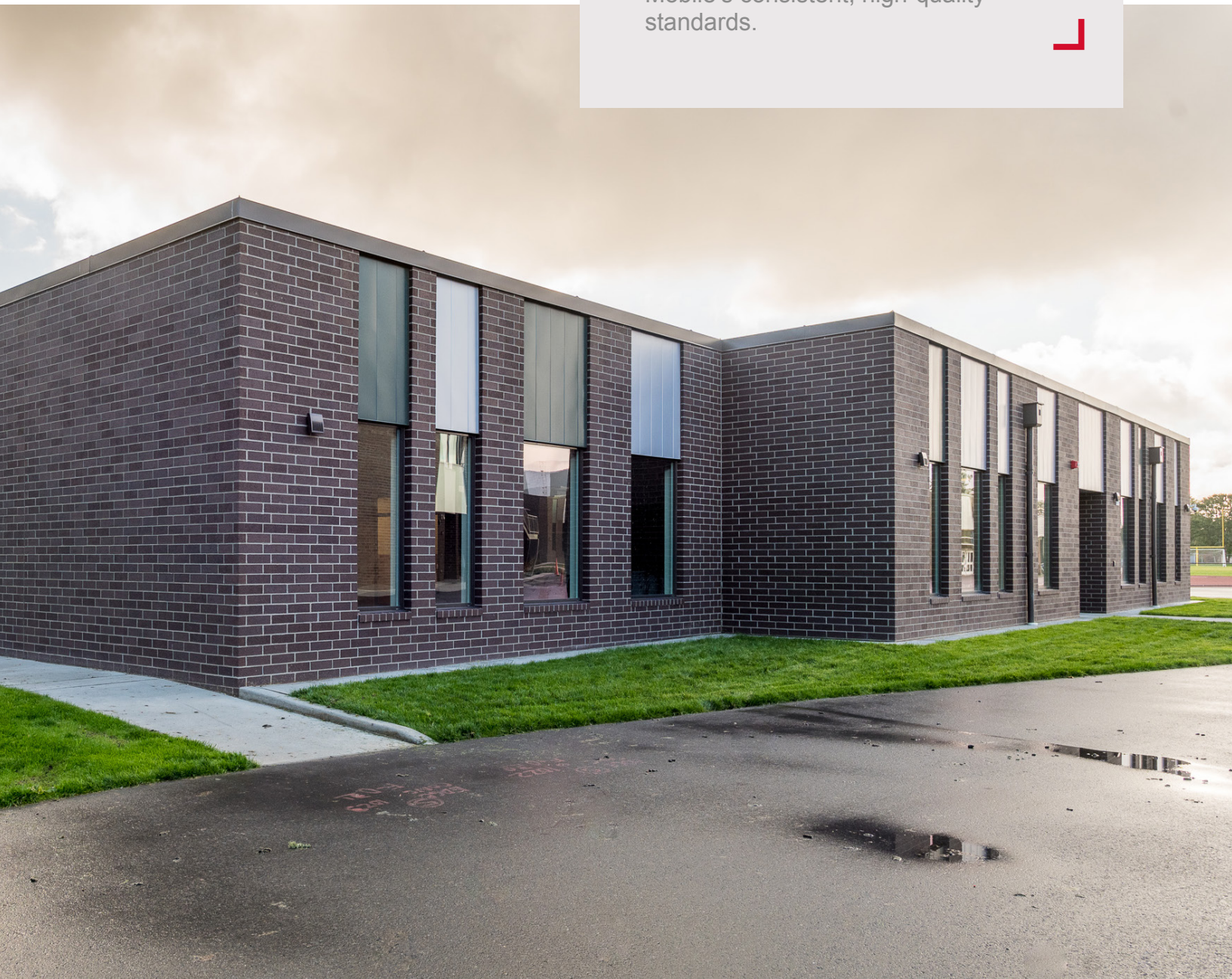



# MOBILE OFFICES

---



## Mint Condition, Workforce Ready

It's a mobile office, but your people will be calling it home for an extended period of time — typically a year or more. When you rent from Pacific Mobile, you get a freshly reconditioned, well-maintained structure that passes our multi-point inspection process to ensure it's delivered in top condition. If you ever see our buildings alongside those of our competitors, the pride we put into our work shows, both inside and out.



**Delivery as ordered.** Your building will arrive on time and accurately meet your specifications. If you need custom walls or partitions, accessibility ramps or steps, furniture or accessories, we'll supply and deliver and set them up on-site, so your people are ready to go to work on day one.

**One-call service.** Your personal Pacific Mobile representative will handle all your orders with our hands-on, first-time-right service commitment. After the structure is set, your personal rep as well as our service and maintenance teams will serve as your advocates for any on-site issues and be at the ready to resolve them with our standard 24-hour response time.

In industries that regularly depend on temporary buildings, leading companies make Pacific Mobile their first-choice provider.



We're widely known for delivering well-maintained, well-appointed buildings that provide pleasant, productive spaces to work.



## STORAGE CONTAINERS

Need extra on-site storage space? All of our regional offices can provide you with storage containers placed on-site to your specification by our expert in-house crews. We also offer ground-level office containers, and combination units subdivided to provide both office and storage space.



Call 800.225.6539 or visit us at [pacificmobile.com](http://pacificmobile.com)



# PERMANENT MODULAR CONSTRUCTION

---



## Yes, You Can Do That with Modular

Put an end to the myths and misconceptions about modular construction. With permanent modular construction from Pacific Mobile, modular structures can take on the aesthetics of their surroundings, incorporate the latest materials and finishes, and be virtually indistinguishable from site-built.

**A general contractor, and staffed like one.** Site superintendents, project managers, engineers, estimators, and site crews are all in-house. Experienced with hundreds of built-for-purpose projects across all industries, we handle a wide scope of projects in terms of size and complexity, and have the financial backing to take on the largest builds. You can trust us to take on your most exacting projects, turnkey them with professionalism, and apply an attention to detail that our competitors can't match.

**Best-of-both construction methods.** You have the advantages of the condensed timeline, transportable strength, and improved quality control of factory-built off-site construction. We combine modular with traditional site-built methods where they're a better fit for key elements of your project.



### Structures delivered 30%-50% faster than conventional.

With modular, site work and factory construction happen simultaneously. In many cases, you can also cut weeks or months of red tape by procuring your structure through one of our high-volume cooperative purchasing contracts.

Modular subassemblies are built with factory quality controls and the structural integrity to handle being moved.

SAGE classrooms combine the latest thinking in healthy learning environments with green building practices.

## SAGE CLASSROOMS

A Pacific Mobile exclusive, Sage classrooms are relocatable structures that can also be placed permanently to create multi-classroom complexes. In their design features, environmental systems, and overall learning environment, they are several notches above any other portable classroom offering available today.



## RELOCATABLE BUILDINGS

Invest in a relocatable building, and you can repurpose it for new uses or move it within or between sites as your need for space evolves. You have the services of our relocation teams for any future moves. They expertly reset and reassemble the structure to preserve the structural integrity as originally designed.



Call 800.225.6539 or visit us at [pacificmobile.com](http://pacificmobile.com)



# SPEED AND EASE

---

## Experience the Pacific Mobile Difference

Find out for yourself. Ask any of the thousands of customers who have turned to us over almost four decades. They'll tell you just how easy and pleasurable it is to do business with us.

### Northwest Region

Chehalis, WA  
Marysville, WA  
Pasco, WA  
Spokane, WA  
Portland, OR  
Boise, ID

### California Region

Modesto, CA  
Riverside, CA  
San Diego, CA

### Arizona Region

Mesa, AZ

### Texas Region

San Antonio / Austin, TX

> 1-800-225-6539 · [www.pacificmobile.com](http://www.pacificmobile.com) · [pmsi@pacificmobile.com](mailto:pmsi@pacificmobile.com)

**PACIFIC**  
**MOBILE STRUCTURES**

## MEMORANDUM

Date: June 21, 2023  
To: Board of Directors  
From: Michael Fritschi, P.E. – Operations Director  
Subject: Lift Station 6B Share of Funding Request

---

### Proposed Action

Approval of a total reimbursement amount of \$85,633.14 which is roughly 29% of the \$299,846 Aqua Sierra estimate of the cost for K Hovnanian Homes (KHov) to increase capacity of District Lift Station 6B (station) per the Districts requirement. Appropriate funds in the amount of \$41,646.00 from the Sewer Improvements fund, which would be that portion of the reimbursement that would not be provided as a discount through the capital sewer fund reduction.

### History

With all new developments, the District enters into a mainline extension agreement (MEA) with Developers for new utility connections. The MEA specifies Developer responsibilities for upsizing infrastructure. The MEA was initially amended to require KHov to assume 100% of the cost of upsizing the District Lift Station 6B to meet the increased base flow. Due to the previously planned improvements of Lift Station 6B and a late realization of the need to expand capacity for the Retreats East and North Development to handle the increased base flow, staff recommend offering a combination of \$85,633.14 in fee reduction and cost share.

In 2017, K Hovnanian Homes (KHov) provided a sewer study for the proposed Retreats East and West development that was reviewed by Coastland Engineering, the prior District Engineer. In that study, it noted that the total “worst case” post development flow is estimated at 122.2 gallons per minute (gpm) and that the existing lift station capacity is rated at 125 gpm. The District Engineer at that time approved the sewer study and the resulting capacity assumptions.

In February of 2022, after KHov had commenced site grading, the District, considering recent storm flows, revisited the 2017 sewer study. It is the District’s current opinion that the initial sewer study completed by Baker-Williams on behalf of KHov did not address this additional base flow properly. The initial sewer study allotted for a pumping capacity of 2-3 gallons per minute over the “worst case” peak wet weather flow with the existing configuration post development. It is Staff’s current opinion that an allotment of less than 10-15% over the expected wet weather flow is too close to be properly conservative for capacity estimation. The study also did not consider the actual working capacity of the station or consider the effects of reduced capacity when pump impellers wear with age.

In March of 2022, the District and KHov entered into an amendment to the existing Facilities Extension Agreement. As part of this amendment, KHov agrees to pay all costs associated with the expansion of the station. In October of 2022, the District directed Domenicelli and Associates, the current District Engineer, to provide a technical memorandum outlining their opinion on the appropriate capacity of the station given the impending development and to provide design information for that capacity as a basis for design. That technical memorandum outlined a post development peak wet weather flow of 142 gpm. The District Engineer was then directed to provide the upgrade design which was completed at the beginning of December of 2022.



In the Fall of 2022, the District and KHov discussed the possibility of the District providing a partial rebate of the sewer capital connection fee based on what percentage of sewer capital fees that the station was previously allocated out of the total capital improvement program. This percentage turned out to be 24.2%. K Hovnanian Homes was granted a 24.2% reduction (by the Board) in capital sewer fees for connections which resulted in a per lot fee reduction of \$709.47, for a total reduction of \$43,987.14 for all 62 lots. K Hovnanian Homes was notified of this in November of 2022 and was sent payment for the reimbursement for connections previously purchased.

In the Spring of 2023, District staff met with K Hovnanian Homes to review additional information provided by K Hovnanian Homes showing I/I trends plotted against rainfall over time. This was provided to the District to show that I/I is existing and to attempt to make the claim that I/I is the cause of the needed additional station capacity and/or that the sewer system was flawed in some way. Staff takes no exception with the study and agrees that there are indeed times when significant I/I is experienced when there are storms with higher precipitation levels.

While it is understood that KHov has made the statement that the District system currently has an existing I/I issue, what must be understood and clear is that the increase in base flow by the added development justifies the requirement to upsize the station, not existing I/I. The inflow and infiltration (I/I) experienced by the sewer system as shown by the Baker-Williams study, while remarkable during larger wet weather events, is by no means extraordinary compared to similar collection systems. The District has not in the past upsized the capacity of the station as the District has not experienced significant issues with I/I where outside pumping is required at a frequency that would call for a capacity upgrade without the addition of base flow. Staff reviewed the data, and while there is existing I/I, the fact remains that the District was not originally looking to upsize the capacity of the station. Staff maintains that it is the additional base flow to be added by the new development that is requiring the additional capacity.

On April 11, 2023, the District received a letter titled "Equitable split of LS 6B Upgrade Costs" in which KHov has requested that the District pay a portion of the Lift Station 6B (station) expansion costs. While Staff does not agree with the I/I related reimbursement claims, Staff does, however, understand that KHov was informed of the station capacity increase requirement well after the review period of the sewer system was completed. Staff also does acknowledge that the existing station pumps would likely need replacing in the next 5-10 years. Therefore, Staff recommends an offer of the sum of \$26,646 to reimburse KHov Homes for what the District would eventually pay for new pumps (at the current capacity) if the development was never approved. (See attached quote for new pumps of existing capacity.)

Staff further understands that while the District has designated variable frequency drives (VFD's) as a means of starting the new pumps, while the District prefers VFD's for pump starters, VFD's are not as common of an application for a lift station configuration such as Lift Station 6B. Therefore, Staff would advise an offer of the sum of \$15,000 to reimburse K Hovnanian Homes for the actual cost of the VFD's and a portion of the electrical work associated with the pump and VFD installation. (See attached Aqua Sierra quote.)

If the Board agrees, the total reimbursement for this station to KHov by the District would equal \$85,633.14 (29% of the cost breakdown of \$299,846 as provided by KHov) in reimbursements and fee reductions described previously in this letter to offset the costs that the District would experience with the station if the development was never to occur.

**att.** Equitable split of LS 6B Upgrade Costs letter by K Hovnanian Homes  
Xylem quote for replacing existing pumps  
Aqua Sierra Quote to upsize station



April 11, 2023

Michael T. Fritschi  
Interim General Manager  
Rancho Murieta Community Services District (RMCS D)  
15160 Jackson Road  
Rancho Murieta, CA 95683  
[mfritschi@rmcsd.com](mailto:mfritschi@rmcsd.com)

RE: Equitable Split of LS 6B Upgrade Costs

Dear Mr. Fritschi:

Please consider the following proposal regarding an equitable split of the costs for improvement of the 6B lift station that was imposed on The Retreats North and East.

**Background:**

A sewer infrastructure study was prepared by Baker-Williams Engineering Group dated April 26, 2017. This study provided evaluation for Retreats North and East. It shows adequate capacity within the sewer system for the proposed project and was accepted by Rancho Murieta Community Services District (RMCS D).

On February 11, 2022 RMCS D's engineer sent a memo to Baker-Williams Engineering Group stating that Lift Station 6B was overwhelmed by the storm of October 25, 2021 and ultimately decided that The Retreats project would not be allowed to proceed without an upgrade to Lift Station 6B. RMCS D at the time was characterizing this issue as an impact from Retreats North and East even though no development had yet been done that would create an impact to the system. Nonetheless RMCS D provided an undated letter in response to my request for reimbursement from sewer impact fees of November 17, 2022 wherein RMCS D agreed to provide a credit of 24.2% of the sewer impact fee per lot connection. This amount is inadequate for the improvement and does not approach any kind of an equitable solution.

Subsequently Baker-Williams prepared a study showing actual flows into Lift Station 6B from 2010 through 2022 and contrasts that with the Cosumnes River stage level as measured at the Michigan Bar station. On March 6, 2023, we met to discuss the findings of the study. The meeting was attended by representatives of RMCS D, Domenichelli & Associates, Baker-Williams, and me. The Baker-Williams flow study shows that the issues of concern related to the 6B Lift Station are not impacts of The Retreats North and East project, but rather are significant infiltration issues that predate The Retreats North and East project.

We submit that infiltration issues are a RMCS D maintenance obligation and not a project impact.

KHOVNANIAN HOMES

15160 Jackson Road, Rancho Murieta, CA 95683 • 916.933.1111

**Proposed Equitable Split of LS 6B Augmentation:**

Baker-Williams looked at this in two ways in order to arrive at a split that would be both equitable and supportable by engineering standards.

**Split based on area of shed:**

- The total shed area is 73 acres; Retreats North and East is 23 acres.
  - RMCS D maintenance responsibility = 68%
  - Retreats North and East responsibility = 32%

**Split based on lot count:**

- Total number of lots flowing to LS6B = 172
  - Unit 6 = 110 lots
  - Retreats North and East = 62
    - RMCS D maintenance responsibility = 64%
    - Retreats North and East responsibility = 36%

Either of the above scenarios are acceptable to K. Hovnanian Homes as would be an average of the two.

Thank you for your consideration. I'm looking forward to discussing this with you.

Sincerely,

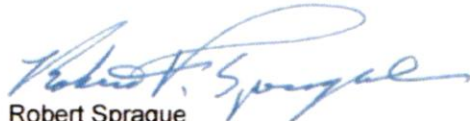

Robert Sprague  
Director, Forward Planning / Land Acquisition

**K. Hovnanian California Region, Inc.**  
**3721 Douglas Blvd, Suite 150**  
**Roseville, CA 95661**

O: 916-945-5404 M: 916-825-8104  
[rsprague@khov.com](mailto:rsprague@khov.com) • [www.khov.com](http://www.khov.com)

CC: Mike Roberts – Baker-Williams Engineering Group  
Doug Dieter – VP Land Acquisition  
Russ Whipple – VP Land Development

Quote to KHVN for LIPT 6B CAPACITY EXPANSION.



Aqua Sierra Controls, Inc.  
1650 Industrial Drive, Auburn, CA 95603  
Cell (530) 305-3390 Office (530) 823-3241  
[jlane@aquasierra.com](mailto:jlane@aquasierra.com) [www.aquasierra.com](http://www.aquasierra.com)  
CA Contractors License A, C-10 474023  
CA Small Business Certification #1162  
CA DIR #1000003631

IT Services - SCADA – UL508 Panel Shop – Pump Controllers  
NIST Traceable Instrument Calibrations & Maintenance

K. Hovnanian California Region, Inc.  
3721 Douglas Blvd. Suite 150  
Roseville, CA 95661

Attention: Mr. Chase Williams  
Phone: 916-886-6193

Subject: Proposal Breakdown  
Project: Rancho Murietta Pump Station 6B

May 2<sup>nd</sup>, 2023

Mr. Williams,

The following is our proposal breakdown as requested.

Main Item Cost Breakdown

Engineering \$16,000.00  
Pumps \$87,000.00  
Panel Modifications \$51,043.04  
Electrical Modifications \$47,000.00  
Plumbing Modifications \$66,000.00  
Pump Bypass \$15,000.00  
VFDs \$7,803.02  
Pump Installation \$10,000.00



Proposal Breakdown

Original Proposal \$186,158.16  
Change Orders \$113,687.90  
**Proposal Total \$299,846.06**



Quote to replace EXISTING LAST 6B PUMPS



**Xylem Water Solutions USA, Inc.**  
**Flygt Products**

May 3, 2023

790-A Chadbourne Rd  
Fairfield, CA 94534  
Tel (707) 422-9894  
Fax (707) 422-9808

RANCHO MURIETA COMMUNITY SERV  
15160 JACKSON RD  
PO BOX 1050  
RANCHO MURIETA CA 95683

Quote # 2023-FFB-0161  
Project Name: Rancho Murieta CSD  
Job Name: Replacement for MP3127

Flygt, a Xylem brand, is pleased to provide a quote for the following equipment.

Equipment				
Qty	Part Number	Description	Unit Price	Extended Price
1	3127.890-0243	Flygt Model MP-3127.890 2" volute Submersible grinder pump equipped with a 230 Volt / 3 phase / 60 Hz 11 HP 3550 RPM motor, 262 impeller, 1 x 30 Ft. length of SUBCAB 4G10+S(2x0,5) submersible cable, FLS leakage detector, volute is prepared for Flush Valve	\$ 13,323.00	\$ 13,323.00
			<b>Total Price</b>	<b>\$ 13,323.00</b>
			<b>Freight Charge</b>	<b>\$ 584.00</b>
			<b>Total Price</b>	<b>\$ 13,907.00</b>

**Terms & Conditions**

This order is subject to the Standard Terms and Conditions of Sale – Xylem Americas effective on the date the order is accepted which terms are available at <http://www.xyleminc.com/en-us/Pages/terms-conditions-of-sale.aspx> and incorporated herein by reference and made a part of the agreement between the parties.

**Purchase Orders:** Please make purchase orders out to: Xylem Water Solutions USA, Inc.

**Freight Terms:** 3 DAP - Delivered At Place 08 - Jobsite (per IncoTerms 2020)  
See Freight Payment (Delivery Terms) below.

**Taxes:** State, local and other applicable taxes are not included in this quotation.

**Back Charges:** Buyer shall not make purchases nor shall Buyer incur any labor that would result in a back charge to Seller without prior written consent of an authorized employee of Seller.

**Shortages:** Xylem will not be responsible for apparent shipment shortages or damages incurred in shipment that are not reported within two weeks from delivery to the





jobsite. Damages should be noted on the receiving slip and the truck driver advised of the damages. Please contact our office as soon as possible to report damages or shortages so that replacement items can be shipped and the appropriate claims made.

**Time of delivery:** Current estimated lead time for this pump is 14 weeks delivered.

**Terms of delivery:** PP/Add Order Position

**Terms of payment:** 100% Net 30 days following shipment date.

**Schedule:** Please consult your local Flygt Branch Office to get fabrication and delivery lead times.

**Validity:** This Quote is valid for thirty (30) days.  
Please note that this pricing is valid for 30 days and contingent upon final approval of submittals and release to fabrication by (within 90 days of bid date).  
This quotation is subject to change if any changes to the specifications or plans are made that alter the scope of supply.

We thank you for your interest in Flygt equipment from Xylem Water Solutions USA, Inc., and look forward to being of service to you in the near future.

Sincerely,



Adrian Gutierrez  
Sales Representative  
Phone: 508-274-4643

[adrian.gutierrez@xylem.com](mailto:adrian.gutierrez@xylem.com)

## RESOLUTION R2023-11

**A RESOLUTION AUTHORIZING THE DISTRICT TO REIMBURSE K HOVNANIAN HOMES TO INCREASE CAPACITY OF DISTRICT LIFT STATION 6B IN THE AMOUNT OF \$85,633.14, TO INCLUDE A \$43,987.14 REDUCTION OF CAPITAL SEWER FEES FOR CONNECTIONS TO 62 LOTS IN RETREATS WEST AND EAST AND \$41,646 FROM THE SEWER IMPROVEMENT FUND IN CASH TO OFFSET THE COSTS THAT THE DISTRICT WOULD PAY TO UPGRADE LIFT STATION 6B, AND TO APPROVE CIP#23-24-02, APPROPRIATE FUNDS IN THE AMOUNT OF \$41,646 AND AUTHORIZING THE GENERAL MANAGER TO REIMBURSE K HOVANIAN HOMES ON BEHALF OF THE DISTRICT**

**WHEREAS,** The District has identified the need to upgrade Lift Station 6B; and

**WHEREAS,** The District has worked with K Hovnanian (KHov) Homes who is currently building Retreats West and East; and

**WHEREAS,** The District has determined that Lift Station 6B needs to meet increased base flow as a result of the new development; and

**WHEREAS,** The District would need to replace the lift station pumps in the future so we will reimburse KHov \$41,646 the estimated cost to replace the pumps and variable frequency drives; and

**WHEREAS,** The District will also reduce the sewer capital connection fee owed by KHov by 24.2% or \$709.47 per lot for 62 lots for a total of \$43,987.14 based on the percentage allocated to Lift 6B Improvements from the 2017 CIP Study; and

**NOW, THEREFORE, THE RANCHO MURIETA COMMUNITY SERVICES DISTRICT DOES HEREBY RESOLVE AS FOLLOWS:**

1. Authorize the General Manager to reimburse KHov in the amount of \$41,646 and (CIP# 23-24-02), attached as Exhibit 1.
2. Authorize a transfer of funds in the amount of \$41,646 from Sewer Improvement Fund and appropriate funds.
3. Authorize the General Manager to approve the reduction of the sewer capital connection fee for 62 lots of Retreats West and East.
4. The General Manager is authorized to carry out all necessary and appropriate actions to the purpose and intent of this resolution.

**PASSED AND ADOPTED** this 21<sup>st</sup> day of June 2023 by the following roll call vote:

**Ayes:**

**Noes:**

**Absent:**

**Abstain:**

\_\_\_\_\_  
Timothy E. Maybee, President of the Board  
Rancho Murieta Community Services District

[SEAL]

Attest:

\_\_\_\_\_  
Amelia Wilder, District Secretary

DRAFT

## MEMORANDUM

Date: June 14, 2023  
To: Board of Directors  
From: Mimi Morris, General Manager  
Subject: Update to Utility Worker and Plant Operator Job Descriptions – Weight Lifting Limit

---

### RECOMMENDED ACTION

District Staff recommends updating the job description for the Utility Workers and Plant Operators to modernize the weight lifting limits and help prevent injury.

### BACKGROUND

The job descriptions for Utility Workers and Plant Operators currently states that the weight lifting requirement is 75 pounds. Staff recommends updating these job descriptions to require maximum lifting of 50 pounds. This is becoming an industry standard and it will help to prevent lifting injuries. Golden State Risk Management Authority (GSRMA), the Districts Workman's Compensation insurer agrees with this requirement change and noted that they typically see less workers' compensation claims associated with lifting and/or handling of objects after districts make this type of change, and the claims they do receive are of less severity due to the reduced weight associated with the lift.

Staff will continue their safe lifting practices, utilizing hand trucks/forklifts/lift tables/etc. to minimize the amount of actual handling, team lifting when possible, and never lifting above their abilities. Our employees are encourage to report to their supervisor if he/she doesn't feel comfortable lifting something, so the supervisor can determine a better method of moving the object.

### SUMMARY

Staff recommends the Board approve these changes to all of the Job Descriptions for Utility Worker and Operations Staff, to help protect staff by decreasing the possibility of lifting injuries and hopefully reduce potential workman's comp claims.

# RANCHO MURIETA COMMUNITY SERVICES DISTRICT

## UTILITY WORKER I

---

DEPARTMENT: WATER/WASTEWATER

FLSA OVERTIME STATUS: NON-EXEMPT

BARGAINING UNIT: OPERATING ENGINEERS LOCAL 3

APPROVED BY BOARD OF DIRECTORS - ~~02/16/05~~ June 21, 2023

---

**SUMMARY:** To perform a variety of unskilled and semiskilled routine duties in the construction, repair, and maintenance of water distribution and collection systems, drainage system maintenance; buildings and grounds maintenance; installation, maintenance and repair of water service lines and meters; to learn progressively more difficult tasks; and to perform other related duties as required.

**SUPERVISION:** Receives direct supervision from the Utility Supervisor.

**ESSENTIAL DUTIES AND RESPONSIBILITIES** include the following. Other duties may be assigned.

- Performs a variety of unskilled and semiskilled labor tasks in the construction and maintenance of water distribution and wastewater collection systems, drainage systems, roads, pipelines and other District facilities;
- maintains districts open channels and ditch systems;
- works in or around hazardous electrical panels and equipment; assists operations staff as needed;
- reads residential and commercial meters; maintains simple records and logs;
- performs a wide variety of maintenance work and other assignments according to District needs.

**DISTINGUISHING CHARACTERISTICS:**

This is the entry level position of the Utility Worker series. Incumbents in this class generally work under direct supervision in any of the work areas specified in the definition above. They perform less complex tasks and receive on-the-job training in the performance of more complex duties. Incumbents will be assigned specific duties according to the District's needs and the individual's ability. As an incumbent gains skill and performs more difficult work through experience and training and a desired level of proficiency is reached, promotion to a higher-level classification can be reasonably



expected. In any of these assignments, incumbents may operate a variety of power driven equipment and tools utilized in basic construction and maintenance activities.

**QUALIFICATION REQUIREMENTS:**

To perform this job successfully, an individual must be able to perform each essential duty satisfactorily. The requirements listed below are representative of the knowledge, skill, and/or ability required.

Ability to perform a variety of unskilled and semiskilled work in construction, repair and maintenance tasks. Use basic hand tools. Learn to operate a variety of equipment and more complex equipment and work procedures. Perform strenuous manual labor. Read and write at the level required for successful job performance. Follow written and oral instructions. Work unusual shifts, weekends, evenings, and holidays when required. Establish and maintain cooperative working relationships.

**EDUCATION AND/OR EXPERIENCE:**

Any combination of training and experience, which would likely provide the required knowledge and ability, is qualifying. A typical way to obtain this knowledge and ability would be:

Minimum Education: High School diploma and/or equivalent.

One year of general laboring work, preferably including water distribution and collection systems repair, maintenance, or construction.

**CERTIFICATES, LICENSES, REGISTRATIONS:**

Possession of the category of California Driver's license required by the State Department of Motor Vehicles to perform the essential duties of the position. Continued maintenance of a valid driver's license, insurability, and compliance with established District vehicle operation standards and requirements are a condition of continuing employment.

Possession and maintenance of a Water Distribution 1 Certificate issued by the California Department of Health Services within 18 months of entering this position is required.

**PHYSICAL DEMANDS:**

The physical demands described here are representative of those that must be met by an employee to successfully perform the essential functions of this job.

While performing the duties of this job, the employee is regularly required to talk or hear. The employee frequently is required to stand; walk; sit; use hands to finger, handle, or feel objects, tools, or controls; reach with hands and arms; climb or balance; and stoop, kneel, crouch, or crawl. The employee is occasionally required to taste or smell.

The employee must frequently lift and/or move up to ~~50~~<sup>75</sup> pounds. Specific vision abilities

required by this job include close vision, distance vision, color vision, peripheral vision, depth perception, and the ability to adjust focus.

**WORK ENVIRONMENT:**

The work environment characteristics described here are representative of those an employee encounters while performing the essential functions of this job. Reasonable accommodations may be made to enable individuals with disabilities to perform the essential functions.

While performing the duties of this job, the employee frequently works in outside weather conditions and is frequently exposed to wet and/or humid conditions. The employee occasionally works near moving mechanical parts and in high, precarious places and is occasionally exposed to extreme cold, extreme heat, vibration, and risk of electrical shock.

The noise level in the work environment is usually moderate.

**COMMENTS:**

Employees appointed to positions in this class are required to be neatly groomed as needed to wear respiratory protection or other safety equipment.

# RANCHO MURIETA COMMUNITY SERVICES DISTRICT

## UTILITY WORKER I

---

DEPARTMENT: WATER/WASTEWATER

FLSA OVERTIME STATUS: NON-EXEMPT

BARGAINING UNIT: OPERATING ENGINEERS LOCAL 3

APPROVED BY BOARD OF DIRECTORS - June 21, 2023

---

**SUMMARY:** To perform a variety of unskilled and semiskilled routine duties in the construction, repair, and maintenance of water distribution and collection systems, drainage system maintenance; buildings and grounds maintenance; installation, maintenance and repair of water service lines and meters; to learn progressively more difficult tasks; and to perform other related duties as required.

**SUPERVISION:** Receives direct supervision from the Utility Supervisor.

**ESSENTIAL DUTIES AND RESPONSIBILITIES** include the following. Other duties may be assigned.

- Performs a variety of unskilled and semiskilled labor tasks in the construction and maintenance of water distribution and wastewater collection systems, drainage systems, roads, pipelines and other District facilities;
- maintains districts open channels and ditch systems;
- works in or around hazardous electrical panels and equipment; assists operations staff as needed;
- reads residential and commercial meters; maintains simple records and logs;
- performs a wide variety of maintenance work and other assignments according to District needs.

**DISTINGUISHING CHARACTERISTICS:**

This is the entry level position of the Utility Worker series. Incumbents in this class generally work under direct supervision in any of the work areas specified in the definition above. They perform less complex tasks and receive on-the-job training in the performance of more complex duties. Incumbents will be assigned specific duties according to the District's needs and the individual's ability. As an incumbent gains skill and performs more difficult work through experience and training and a desired level of proficiency is reached, promotion to a higher-level classification can be reasonably expected. In any of these assignments, incumbents may operate a variety of power driven

equipment and tools utilized in basic construction and maintenance activities.

**QUALIFICATION REQUIREMENTS:**

To perform this job successfully, an individual must be able to perform each essential duty satisfactorily. The requirements listed below are representative of the knowledge, skill, and/or ability required.

Ability to perform a variety of unskilled and semiskilled work in construction, repair and maintenance tasks. Use basic hand tools. Learn to operate a variety of equipment and more complex equipment and work procedures. Perform strenuous manual labor. Read and write at the level required for successful job performance. Follow written and oral instructions. Work unusual shifts, weekends, evenings, and holidays when required. Establish and maintain cooperative working relationships.

**EDUCATION AND/OR EXPERIENCE:**

Any combination of training and experience, which would likely provide the required knowledge and ability, is qualifying. A typical way to obtain this knowledge and ability would be:

Minimum Education: High School diploma and/or equivalent.

One year of general laboring work, preferably including water distribution and collection systems repair, maintenance, or construction.

**CERTIFICATES, LICENSES, REGISTRATIONS:**

Possession of the category of California Driver's license required by the State Department of Motor Vehicles to perform the essential duties of the position. Continued maintenance of a valid driver's license, insurability, and compliance with established District vehicle operation standards and requirements are a condition of continuing employment.

Possession and maintenance of a Water Distribution 1 Certificate issued by the California Department of Health Services within 18 months of entering this position is required.

**PHYSICAL DEMANDS:**

The physical demands described here are representative of those that must be met by an employee to successfully perform the essential functions of this job.

While performing the duties of this job, the employee is regularly required to talk or hear. The employee frequently is required to stand; walk; sit; use hands to finger, handle, or feel objects, tools, or controls; reach with hands and arms; climb or balance; and stoop, kneel, crouch, or crawl. The employee is occasionally required to taste or smell.

The employee must frequently lift and/or move up to 50 pounds. Specific vision abilities required by this job include close vision, distance vision, color vision, peripheral vision, depth perception, and the ability to adjust focus.

**WORK ENVIRONMENT:**

The work environment characteristics described here are representative of those an employee encounters while performing the essential functions of this job. Reasonable accommodations may be made to enable individuals with disabilities to perform the essential functions.

While performing the duties of this job, the employee frequently works in outside weather conditions and is frequently exposed to wet and/or humid conditions. The employee occasionally works near moving mechanical parts and in high, precarious places and is occasionally exposed to extreme cold, extreme heat, vibration, and risk of electrical shock.

The noise level in the work environment is usually moderate.

**COMMENTS:**

Employees appointed to positions in this class are required to be neatly groomed as needed to wear respiratory protection or other safety equipment.



# RANCHO MURIETA COMMUNITY SERVICES DISTRICT

## UTILITY WORKER II

---

DEPARTMENT: WATER/WASTEWATER

FLSA OVERTIME STATUS: NON-EXEMPT

BARGAINING UNIT: OPERATING ENGINEERS LOCAL 3

APPROVED BY BOARD OF DIRECTORS - 02/16/05 [June 21, 2023](#)

---

**SUMMARY:** Performs a variety of skilled and semiskilled routine duties in the construction, repair, and maintenance of water distribution and collection systems; drainage system maintenance; buildings and grounds maintenance; installation, maintenance and repair of water service lines and meters; to operate a variety of light and moderately heavy equipment; and to perform other related duties as required.

**SUPERVISION:** Receives direct supervision from the Utility Supervisor.

**ESSENTIAL DUTIES AND RESPONSIBILITIES** include the following. Other duties may be assigned.

- Performs a variety of skilled and skilled laboring tasks in the construction and maintenance of water distribution and collection systems, drainage system, roads, pipelines and other District facilities;
- maintains districts open channels and ditch systems; applies herbicides, pesticides and fertilizers;
- investigates customer complaints related to water, wastewater and drainage system operation; reads residential and commercial meters;
- works in or around hazardous electrical panels and equipment; assists operations staff as needed;
- observes variations in operating conditions and makes appropriate adjustments;
- reads residential and commercial meters; enters data into computer;
- updates and maintains daily shift log;
- operates backhoe, dump truck, jetting unit or other equipment;

- performs a wide variety of maintenance work according to District needs.

**DISTINGUISHING CHARACTERISTICS:**

This is the Journey level position in the Utility Worker series. Incumbents in this class work under supervision in any of the work areas specified in the definition above. They are expected to perform all types of skilled and semi-skilled tasks in the repair and maintenance of District water distribution and collection systems and related buildings, grounds and facilities. Incumbents will be assigned specific duties according to the District's needs and the individual's ability. In any of these assignments, incumbents operate a variety of power driven equipment and tools utilized in basic construction and maintenance activities.

**QUALIFICATION REQUIREMENTS:**

To perform this job successfully, an individual must be able to perform each essential duty satisfactorily. The requirements listed below are representative of the knowledge, skill, and/or ability required.

Ability to perform a variety of unskilled and semiskilled work in construction, repair and maintenance tasks. Operate effectively a variety of light and moderately heavy mechanical equipment. Skillfully use hand and power tools. Perform strenuous manual labor. Read and write at the level required for successful job performance. Follow written and oral instructions. Oversee the completion of tasks and projects independently. Work unusual shifts, weekends, evenings, and holidays when required. Establish and maintain cooperative working relationships.

**EDUCATION AND/OR EXPERIENCE:**

Any combination of training and experience, which would likely provide the required knowledge and ability, is qualifying. A typical way to obtain this knowledge and ability would be either:

Minimum Education: High School diploma and/or equivalent.

One year of experience as a Utility Worker I with Rancho Murieta Community Services District; *or*

Two years of general laboring work involving repair and maintenance of water distribution and collection equipment, grounds, facilities and systems.

**CERTIFICATES, LICENSES, REGISTRATIONS:**

Possession of the category of California Driver's license required by the State Department of Motor Vehicles to perform the essential duties of the position. Continued maintenance of a valid driver's license, insurability, and compliance with established District vehicle operation standards are a condition of continuing employment.

Possession and maintenance of a Water Distribution 1 Certificate issued by the California Department of Health Services within 18 months of entering this position is required.

Possession of Grade 2 or higher Water Distribution Operator certificate is highly desired.

**PHYSICAL DEMANDS:**

The physical demands described here are representative of those that must be met by an employee to successfully perform the essential functions of this job.

While performing the duties of this job, the employee is frequently required to stand; walk; sit; use hands to finger, handle, or feel objects, tools, or controls; reach with hands and arms; climb or balance; stoop, kneel, crouch, or crawl; and talk or hear.

The employee must frequently lift and/or move up to ~~75~~50 pounds. Specific vision abilities required by this job include close vision, distance vision, color vision, peripheral vision, depth perception, and the ability to adjust focus.

**WORK ENVIRONMENT:**

The work environment characteristics described here are representative of those an employee encounters while performing the essential functions of this job. Reasonable accommodations may be made to enable individuals with disabilities to perform the essential functions.

While performing the duties of this job, the employee frequently works in outside weather conditions and is frequently exposed to wet and/or humid conditions. The employee occasionally works near moving mechanical parts and in high, precarious places and is occasionally exposed to toxic or caustic chemicals and vibration, risk of electrical shock.

The noise level in the work environment is usually loud.

**COMMENTS:**

Employees appointed to positions in this class are required to be neatly groomed as needed to wear respiratory protection or other safety equipment.

# RANCHO MURIETA COMMUNITY SERVICES DISTRICT

## UTILITY WORKER II

---

DEPARTMENT: WATER/WASTEWATER

FLSA OVERTIME STATUS: NON-EXEMPT

BARGAINING UNIT: OPERATING ENGINEERS LOCAL 3

APPROVED BY BOARD OF DIRECTORS - June 21, 2023

---

**SUMMARY:** Performs a variety of skilled and semiskilled routine duties in the construction, repair, and maintenance of water distribution and collection systems; drainage system maintenance; buildings and grounds maintenance; installation, maintenance and repair of water service lines and meters; to operate a variety of light and moderately heavy equipment; and to perform other related duties as required.

**SUPERVISION:** Receives direct supervision from the Utility Supervisor.

**ESSENTIAL DUTIES AND RESPONSIBILITIES** include the following. Other duties may be assigned.

- Performs a variety of skilled and skilled laboring tasks in the construction and maintenance of water distribution and collection systems, drainage system, roads, pipelines and other District facilities;
- maintains districts open channels and ditch systems; applies herbicides, pesticides and fertilizers;
- investigates customer complaints related to water, wastewater and drainage system operation; reads residential and commercial meters;
- works in or around hazardous electrical panels and equipment; assists operations staff as needed;
- observes variations in operating conditions and makes appropriate adjustments;
- reads residential and commercial meters; enters data into computer;
- updates and maintains daily shift log;
- operates backhoe, dump truck, jetting unit or other equipment;
- performs a wide variety of maintenance work according to District needs.

**DISTINGUISHING CHARACTERISTICS:**

This is the Journey level position in the Utility Worker series. Incumbents in this class work under supervision in any of the work areas specified in the definition above. They are expected to perform all types of skilled and semi-skilled tasks in the repair and maintenance of District water distribution and collection systems and related buildings, grounds and facilities. Incumbents will be assigned specific duties according to the District's needs and the individual's ability. In any of these assignments, incumbents operate a variety of power driven equipment and tools utilized in basic construction and maintenance activities.

**QUALIFICATION REQUIREMENTS:**

To perform this job successfully, an individual must be able to perform each essential duty satisfactorily. The requirements listed below are representative of the knowledge, skill, and/or ability required.

Ability to perform a variety of unskilled and semiskilled work in construction, repair and maintenance tasks. Operate effectively a variety of light and moderately heavy mechanical equipment. Skillfully use hand and power tools. Perform strenuous manual labor. Read and write at the level required for successful job performance. Follow written and oral instructions. Oversee the completion of tasks and projects independently. Work unusual shifts, weekends, evenings, and holidays when required. Establish and maintain cooperative working relationships.

**EDUCATION AND/OR EXPERIENCE:**

Any combination of training and experience, which would likely provide the required knowledge and ability, is qualifying. A typical way to obtain this knowledge and ability would be either:

Minimum Education: High School diploma and/or equivalent.

One year of experience as a Utility Worker I with Rancho Murieta Community Services District; *or*

Two years of general laboring work involving repair and maintenance of water distribution and collection equipment, grounds, facilities and systems.

**CERTIFICATES, LICENSES, REGISTRATIONS:**

Possession of the category of California Driver's license required by the State Department of Motor Vehicles to perform the essential duties of the position. Continued maintenance of a valid driver's license, insurability, and compliance with established District vehicle operation standards are a condition of continuing employment.

Possession and maintenance of a Water Distribution 1 Certificate issued by the California Department of Health Services within 18 months of entering this position is required.

Possession of Grade 2 or higher Water Distribution Operator certificate is highly desired.

**PHYSICAL DEMANDS:**

The physical demands described here are representative of those that must be met by an employee to successfully perform the essential functions of this job.

While performing the duties of this job, the employee is frequently required to stand; walk; sit; use hands to finger, handle, or feel objects, tools, or controls; reach with hands and arms; climb or balance; stoop, kneel, crouch, or crawl; and talk or hear.

The employee must frequently lift and/or move up to 50 pounds. Specific vision abilities required by this job include close vision, distance vision, color vision, peripheral vision, depth perception, and the ability to adjust focus.

**WORK ENVIRONMENT:**

The work environment characteristics described here are representative of those an employee encounters while performing the essential functions of this job. Reasonable accommodations may be made to enable individuals with disabilities to perform the essential functions.

While performing the duties of this job, the employee frequently works in outside weather conditions and is frequently exposed to wet and/or humid conditions. The employee occasionally works near moving mechanical parts and in high, precarious places and is occasionally exposed to toxic or caustic chemicals and vibration, risk of electrical shock.

The noise level in the work environment is usually loud.

**COMMENTS:**

Employees appointed to positions in this class are required to be neatly groomed as needed to wear respiratory protection or other safety equipment.



## RANCHO MURIETA COMMUNITY SERVICES DISTRICT

### UTILITY WORKER III

---

DEPARTMENT: WATER/WASTEWATER

FLSA OVERTIME STATUS: NON-EXEMPT

BARGAINING UNIT: OPERATING ENGINEERS LOCAL 3

---

APPROVED BY BOARD OF DIRECTORS - ~~11/19/2008~~ June 21, 2023

---

**SUMMARY:** Performs a variety of skilled and semiskilled routine duties in the construction, repair, and maintenance of water distribution and collection systems; drainage system maintenance; buildings and grounds maintenance; installation, maintenance and repair of water service lines and meters; to operate a variety of equipment; and to perform other related duties as required. Oversees Utility I & II workers.

**SUPERVISION:** Receives direct supervision from the Utility Supervisor.

**ESSENTIAL DUTIES AND RESPONSIBILITIES** include the following. Other duties may be assigned.

- Performs a variety of skilled and skilled laboring tasks in the construction and maintenance of water distribution and collection systems, drainage system, roads, pipelines and other District facilities;
- inspects job sites to check on work progress, assure satisfactory completion and plan new assignments;
- maintains districts open channels and ditch systems;
- investigates customer complaints related to water, wastewater and drainage system operation; reads residential and commercial meters;
- works in or around hazardous panels and equipment; assists operations staff as needed;
- observes variations in operating conditions and makes appropriate suggestions or adjustments;
- reads residential and commercial meters; enters data into computer;
- mark out District utilities for USAs;

Z:\debbby\Admin\_Asst\Job-Descriptions\2005\Utility-Worker-3.doc

- makes water and sewer line repairs;
- updates and maintains daily shift log; tracks meter, distribution, and other repairs on Districts network;
- operates backhoe, dump truck, jetting unit or other equipment;
- performs a wide variety of maintenance work according to District needs.

Formatted: Not Expanded by / Condensed by

Formatted: Left, Line spacing: single, Hyphenate, Tab stops: Not at -0.5"

#### **DISTINGUISHING CHARACTERISTICS:**

This is the advanced working level in the Utility Operator series. Incumbents are expected to perform the more difficult operations and maintenance assignments with minimum guidance and supervision in the repair and maintenance of District water distribution, collection systems and related buildings, grounds and facilities; to provide work direction and assist the Utility Supervisor; to have daily responsibility for field operations and its maintenance; train other staff to operate a variety of power driven equipment and tools utilized in construction and maintenance activities, safety equipment, and all aspects of distribution operations.

#### **QUALIFICATION REQUIREMENTS:**

To perform this job successfully, an individual must be able to perform each essential duty satisfactorily. The requirements listed below are representative of the knowledge, skill, and ability required.

Must have ability to perform a variety of unskilled and semi-skilled work in construction repair and maintenance tasks above and below ground.

Ability to oversee and train personnel in a wide range of repair and maintenance work at water, wastewater and drainage facilities; Effectively operate a variety of light and moderately heavy mechanical equipment. Read and interpret sewer and water system maps and engineering drawings. Keep records and prepare reports as needed. Skillfully use hand and power tools. Safely operate backhoe and related equipment in and around other utilities. Use computer equipment and related peripheral equipment to enter and extract information. Perform strenuous manual labor. Insure proper use and maintenance of Personal Protective Equipment. Read and write at the level required for successful job performance. Follow and give written and oral instructions. Oversee the completion of tasks and projects independently and as a team. Work unusual shifts, weekends, evenings, and holidays when required, as well as work standby and respond to emergency calls. Establish and maintain cooperative working relationships. Fill in for District Utility Supervisor position and duties as necessary.

**EDUCATION AND/OR EXPERIENCE:**

Any combination of training and experience, which would likely provide the required knowledge and ability, is qualifying;

Minimum Education: High School diploma and/or equivalent.

Candidates must be 18 years of age prior to appointment because of the hazards of the job, as defined by the Fair Labor Standards Act.

Three years of experience as a Utility Worker II with Rancho Murieta Community Services District or equivalent work elsewhere, *and*

Two years of general laboring work involving repair and maintenance of water distribution and collection equipment, grounds, facilities and systems.

**CERTIFICATES, LICENSES, REGISTRATIONS:**

Possession of the category of California Driver's license required by the State Department of Motor Vehicles to perform the essential duties of the position. Continued maintenance of a valid driver's license, insurability, and compliance with established District vehicle operation standards are a condition of continuing employment.

Possession and maintenance of a Water Distribution 1 Certificate issued by the California Public Department of Health and must obtain Water Distribution 2 Certificate within 18 months of entering this position. Incumbent must complete the appropriate amount of continuing education hours as required by the State of California to maintain the certification.

Failure to obtain and maintain the appropriate credentials may constitute a cause for termination from this appointment.

Possession of higher Water Distribution Operator certification Grades and CWEA collection system operator I certification is highly desired and will be mandatory should the system change and require it.

**PHYSICAL DEMANDS:**

The physical demands described here are representative of those that must be met by an employee to successfully perform the essential functions of this job.

While performing the duties of this job, the employee is frequently required to stand; walk; sit; use hands to handle or feel objects, tools, or controls; reach with hands and arms; climb or balance; stoop, kneel, crouch, or crawl; and talk or hear.

The employee must frequently lift and/or move up to ~~75~~50 pounds. Specific vision abilities required by this job include close vision, distance vision, color vision, peripheral vision, depth perception, and the ability to adjust focus. Must meet the rating capacity of equipment in order to perform duties of the position; Frequently bend, stoop, squat, kneel, crouch and reach above the shoulder; Wear respirators as needed to perform work.

**WORK ENVIRONMENT:**

The work environment characteristics described here are representative of those an employee encounters while performing the essential functions of this job. Reasonable accommodations may be made to enable individuals with disabilities to perform the essential functions.

While performing the duties of this job, the employee frequently works in outside weather conditions and is frequently exposed to wet and/or humid conditions. The employee occasionally works near moving mechanical parts and in high, precarious places and is occasionally exposed to toxic or caustic chemicals and vibration, risk of electrical shock.

The noise level in the work environment is usually loud.

**COMMENTS:**

Employees appointed to positions in this class are required to be neatly groomed as needed to wear respiratory protection or other safety equipment.

Appointment to this position falls under a one year probationary period with the District.

**Utility III Wage Schedule 2008—proposed**

A ————— B ————— C ————— D ————— F ————— G ————— H  
(See excel spreadsheet)

# RANCHO MURIETA COMMUNITY SERVICES DISTRICT

## UTILITY WORKER III

---

DEPARTMENT: WATER/WASTEWATER

FLSA OVERTIME STATUS: NON-EXEMPT

BARGAINING UNIT: OPERATING ENGINEERS LOCAL 3

APPROVED BY BOARD OF DIRECTORS - June 21, 2023

---

**SUMMARY:** Performs a variety of skilled and semiskilled routine duties in the construction, repair, and maintenance of water distribution and collection systems; drainage system maintenance; buildings and grounds maintenance; installation, maintenance and repair of water service lines and meters; to operate a variety of equipment; and to perform other related duties as required. Oversees Utility I & II workers.

**SUPERVISION:** Receives direct supervision from the Utility Supervisor.

**ESSENTIAL DUTIES AND RESPONSIBILITIES** include the following. Other duties may be assigned.

- Performs a variety of skilled and skilled laboring tasks in the construction and maintenance of water distribution and collection systems, drainage system, roads, pipelines and other District facilities;
- inspects job sites to check on work progress, assure satisfactory completion and plan new assignments;
- maintains districts open channels and ditch systems;
- investigates customer complaints related to water, wastewater and drainage system operation; reads residential and commercial meters;
- works in or around hazardous panels and equipment; assists operations staff as needed;
- observes variations in operating conditions and makes appropriate suggestions or adjustments;
- reads residential and commercial meters; enters data into computer;
- mark out District utilities for USAs;

- makes water and sewer line repairs;
- updates and maintains daily shift log; tracks meter, distribution, and other repairs on Districts network;
- operates backhoe, dump truck, jetting unit or other equipment;
- performs a wide variety of maintenance work according to District needs.

**DISTINGUISHING CHARACTERISTICS:**

This is the advanced working level in the Utility Operator series. Incumbents are expected to perform the more difficult operations and maintenance assignments with minimum guidance and supervision in the repair and maintenance of District water distribution, collection systems and related buildings, grounds and facilities; to provide work direction and assist the Utility Supervisor; to have daily responsibility for field operations and its maintenance; train other staff to operate a variety of power driven equipment and tools utilized in construction and maintenance activities, safety equipment, and all aspects of distribution operations.

**QUALIFICATION REQUIREMENTS:**

To perform this job successfully, an individual must be able to perform each essential duty satisfactorily. The requirements listed below are representative of the knowledge, skill, and ability required.

Must have ability to perform a variety of unskilled and semi-skilled work in construction repair and maintenance tasks above and below ground.

Ability to oversee and train personnel in a wide range of repair and maintenance work at water, wastewater and drainage facilities; Effectively operate a variety of light and moderately heavy mechanical equipment. Read and interpret sewer and water system maps and engineering drawings. Keep records and prepare reports as needed. Skillfully use hand and power tools. Safely operate backhoe and related equipment in and around other utilities. Use computer equipment and related peripheral equipment to enter and extract information. Perform strenuous manual labor. Insure proper use and maintenance of Personal Protective Equipment. Read and write at the level required for successful job performance. Follow and give written and oral instructions. Oversee the completion of tasks and projects independently and as a team. Work unusual shifts, weekends, evenings, and holidays when required, as well as work standby and respond to emergency calls. Establish and maintain cooperative working relationships. Fill in for District Utility Supervisor position and duties as necessary.

**EDUCATION AND/OR EXPERIENCE:**



Any combination of training and experience, which would likely provide the required knowledge and ability, is qualifying;

Minimum Education: High School diploma and/or equivalent.

Candidates must be 18 years of age prior to appointment because of the hazards of the job, as defined by the Fair Labor Standards Act.

Three years of experience as a Utility Worker II with Rancho Murieta Community Services District or equivalent work elsewhere, *and*

Two years of general laboring work involving repair and maintenance of water distribution and collection equipment, grounds, facilities and systems.

**CERTIFICATES, LICENSES, REGISTRATIONS:**

Possession of the category of California Driver's license required by the State Department of Motor Vehicles to perform the essential duties of the position. Continued maintenance of a valid driver's license, insurability, and compliance with established District vehicle operation standards are a condition of continuing employment.

Possession and maintenance of a Water Distribution 1 Certificate issued by the California Public Department of Health and must obtain Water Distribution 2 Certificate within 18 months of entering this position. Incumbent must complete the appropriate amount of continuing education hours as required by the State of California to maintain the certification.

Failure to obtain and maintain the appropriate credentials may constitute a cause for termination from this appointment.

Possession of higher Water Distribution Operator certification Grades and CWEA collection system operator I certification is highly desired and will be mandatory should the system change and require it.

**PHYSICAL DEMANDS:**

The physical demands described here are representative of those that must be met by an employee to successfully perform the essential functions of this job.

While performing the duties of this job, the employee is frequently required to stand; walk; sit; use hands to handle or feel objects, tools, or controls; reach with hands and arms; climb or balance; stoop, kneel, crouch, or crawl; and talk or hear.

The employee must frequently lift and/or move up to 50 pounds. Specific vision abilities required by this job include close vision, distance vision, color vision, peripheral vision, depth perception, and the ability to adjust focus. Must meet the rating capacity of

equipment in order to perform duties of the position; Frequently bend, stoop, squat, kneel, crouch and reach above the shoulder; Wear respirators as needed to perform work.

**WORK ENVIRONMENT:**

The work environment characteristics described here are representative of those an employee encounters while performing the essential functions of this job. Reasonable accommodations may be made to enable individuals with disabilities to perform the essential functions.

While performing the duties of this job, the employee frequently works in outside weather conditions and is frequently exposed to wet and/or humid conditions. The employee occasionally works near moving mechanical parts and in high, precarious places and is occasionally exposed to toxic or caustic chemicals and vibration, risk of electrical shock.

The noise level in the work environment is usually loud.

**COMMENTS:**

Employees appointed to positions in this class are required to be neatly groomed as needed to wear respiratory protection or other safety equipment.

Appointment to this position falls under a one year probationary period with the District.

# RANCHO MURIETA COMMUNITY SERVICES DISTRICT

## OPERATOR IN TRAINING (OIT)

---

DEPARTMENT: WATER/WASTEWATER

FLSA OVERTIME STATUS: NON-EXEMPT

BARGAINING UNIT: OPERATING ENGINEERS LOCAL 3

APPROVED BY BOARD OF DIRECTORS – ~~12/16/09~~ June 21, 2023

---

**SUMMARY:** To assist with the control, operation, and maintenance of District water and wastewater treatment and various pumping facilities, machinery, equipment, structures, and grounds, and to perform other related duties as required.

**SUPERVISION:** Receives direct supervision from the Chief Plant Operator.

**ESSENTIAL DUTIES AND RESPONSIBILITIES** include the following. Other duties may be assigned.

- Assists with controlling the operation of water and wastewater treatment and pumping facilities to achieve proper processing of wastewater and disposal of sludge and effluent within mandated operating requirements; assists with the monitoring of treatment processes and enters data in appropriate logs;
- assists with starting and controlling plant processes, chemical systems, and power generators in a safe and orderly manner; keeps machinery, equipment, structures, piping, work areas, grounds, and landscaped areas in a clean and orderly condition;
- assists others as needed, maintenance of grounds, machinery and equipment maintenance, repair, and overhaul;
- assists with the transport and storage of hazardous chemicals and gases; utilize self contained breathing apparatus as required; inspects pumping stations, control equipment, facilities, and grounds for needed maintenance and repairs and unusual operating conditions;
- assists in the operation, repair, and maintenance of related storm and drainage systems, lifting and pump stations and collection systems;
- learns how to perform operating procedures; learns sample collection and laboratory testing and analytical procedures; work in or around hazardous electrical

panels and equipment;

- learns and trains in proper operating and safety procedures for normal operations, chlorine leaks and other emergencies.

**DISTINGUISHING CHARACTERISTICS:**

This is the entry and training level in the Plant Operator class series. Incumbents work in a training status under supervision of a qualified, certified and experienced operator until necessary certifications are achieved.

**QUALIFICATION REQUIREMENTS:**

To perform this job successfully, an individual must be able to perform each essential duty satisfactorily. The requirements listed below are representative of the knowledge, skill, and/or ability required.

The ability to learn and apply the practices, procedures, techniques, regulations, and laws pertaining to water and wastewater treatment plant and pumping facilities operations and maintenance, and the ability to learn to operate and perform routine maintenance on treatment plant equipment and related facilities. Learn to read and interpret a variety of meters, gages, recording charts, and mechanical and piping diagrams. Have the ability to perform a variety of skilled and semiskilled maintenance and repair work. Understand and carry out oral and written instructions. Maintain and update records and logs in paper and electronic format using computer software such as word processing, spreadsheets, computerized maintenance management software, etc. Work unusual shifts, weekends, evenings, overtime, and holidays when required. Establish and maintain cooperative working relationships.

**EDUCATION AND/OR EXPERIENCE:**

Must be eighteen (18) years of age prior to appointment because of the hazards of the job, as defined by the Fair Labor Standards Act.

Minimum Education: High School diploma and/or equivalent.

No experience is necessary to obtain this position, however any combination of training and experience, which would likely provide the required knowledge and ability, is qualifying. A typical way to obtain this knowledge and ability would be:

One year of experience as a Utility Worker with the District; *or*

One year of general work experience in the operation and maintenance of machinery and equipment, preferably including water treatment, wastewater treatment, water distribution, or wastewater collection systems equipment and facilities.

**CERTIFICATES, LICENSES, REGISTRATIONS:**

Possession of the category of a valid California Driver's license required by the State Department of Motor Vehicles to perform the essential duties of the position. Continued maintenance of a valid driver's license, insurability, and compliance with established District vehicle operation standards are a condition of continuing employment.

Possession and maintenance of a CA Grade 1 Water Treatment Operator's Certificate by the California Department of Public Health, is required within 18 months of hire date.

Immediately upon hire, the OIT must file an OIT application with the State Water Resources Control Board (SWRCB) Office of Operator Certification for a Grade 1 OIT certificate, signed by the District's Chief Plant Operator.

Possession and maintenance of a CA Grade I Wastewater Treatment Certificate by the State Water Resources Control Board within 24 months of entering this position is required.

Promotion to Plant Operator I is at the discretion of the District, position availability, and is not automatic upon obtaining required certifications.

**PHYSICAL DEMANDS:**

The physical demands described here are representative of those that must be met by an employee to successfully perform the essential functions of this job.

While performing the duties of this job, the employee is regularly required to stoop, kneel, crouch, or crawl. The employee frequently is required to stand, walk, sit, and climb or balance. The employee is occasionally required to use hands to finger, handle, or feel objects, tools, or controls; reach with hands and arms; talk or hear; and taste or smell.

The employee must occasionally lift and/or move up to ~~75~~50 pounds. Specific vision abilities required by this job include close vision, distance vision, color vision to interpret a variety of colors on graphical and computer displays, peripheral vision, depth perception, and the ability to adjust focus.

**WORK ENVIRONMENT:**

The work environment characteristics described here are representative of those an employee encounters while performing the essential functions of this job. Reasonable accommodations may be made to enable individuals with disabilities to perform the essential functions.

While performing the duties of this job, the employee is frequently exposed to wet and/or humid conditions. The employee occasionally works near moving mechanical parts; in high, precarious places, and in outside weather conditions and is occasionally exposed to toxic or caustic chemicals, extreme cold, extreme heat, and vibration. The noise level in the work environment is usually loud.

Z:\debbby\Admin-Asst\Job-Descriptions\2005 & later\OIT.doc

**COMMENTS:**

Employees appointed to positions in this class are required to be neatly groomed as needed to wear respiratory protection or other safety equipment. Ability to wear and use SCBA units as regulated by Cal/OSHA.



# RANCHO MURIETA COMMUNITY SERVICES DISTRICT

## OPERATOR IN TRAINING (OIT)

---

DEPARTMENT: WATER/WASTEWATER

FLSA OVERTIME STATUS: NON-EXEMPT

BARGAINING UNIT: OPERATING ENGINEERS LOCAL 3

APPROVED BY BOARD OF DIRECTORS – June 21, 2023

---

**SUMMARY:** To assist with the control, operation, and maintenance of District water and wastewater treatment and various pumping facilities, machinery, equipment, structures, and grounds, and to perform other related duties as required.

**SUPERVISION:** Receives direct supervision from the Chief Plant Operator.

**ESSENTIAL DUTIES AND RESPONSIBILITIES** include the following. Other duties may be assigned.

- Assists with controlling the operation of water and wastewater treatment and pumping facilities to achieve proper processing of wastewater and disposal of sludge and effluent within mandated operating requirements; assists with the monitoring of treatment processes and enters data in appropriate logs;
- assists with starting and controlling plant processes, chemical systems, and power generators in a safe and orderly manner; keeps machinery, equipment, structures, piping, work areas, grounds, and landscaped areas in a clean and orderly condition;
- assists others as needed, maintenance of grounds, machinery and equipment maintenance, repair, and overhaul;
- assists with the transport and storage of hazardous chemicals and gases; utilize self contained breathing apparatus as required; inspects pumping stations, control equipment, facilities, and grounds for needed maintenance and repairs and unusual operating conditions;
- assists in the operation, repair, and maintenance of related storm and drainage systems, lifting and pump stations and collection systems;
- learns how to perform operating procedures; learns sample collection and laboratory testing and analytical procedures; work in or around hazardous electrical panels and equipment;

- learns and trains in proper operating and safety procedures for normal operations, chlorine leaks and other emergencies.

**DISTINGUISHING CHARACTERISTICS:**

This is the entry and training level in the Plant Operator class series. Incumbents work in a training status under supervision of a qualified, certified and experienced operator until necessary certifications are achieved.

**QUALIFICATION REQUIREMENTS:**

To perform this job successfully, an individual must be able to perform each essential duty satisfactorily. The requirements listed below are representative of the knowledge, skill, and/or ability required.

The ability to learn and apply the practices, procedures, techniques, regulations, and laws pertaining to water and wastewater treatment plant and pumping facilities operations and maintenance, and the ability to learn to operate and perform routine maintenance on treatment plant equipment and related facilities. Learn to read and interpret a variety of meters, gages, recording charts, and mechanical and piping diagrams. Have the ability to perform a variety of skilled and semiskilled maintenance and repair work. Understand and carry out oral and written instructions. Maintain and update records and logs in paper and electronic format using computer software such as word processing, spreadsheets, computerized maintenance management software, etc. Work unusual shifts, weekends, evenings, overtime, and holidays when required. Establish and maintain cooperative working relationships.

**EDUCATION AND/OR EXPERIENCE:**

Must be eighteen (18) years of age prior to appointment because of the hazards of the job, as defined by the Fair Labor Standards Act.

Minimum Education: High School diploma and/or equivalent.

No experience is necessary to obtain this position, however any combination of training and experience, which would likely provide the required knowledge and ability, is qualifying. A typical way to obtain this knowledge and ability would be:

One year of experience as a Utility Worker with the District; *or*

One year of general work experience in the operation and maintenance of machinery and equipment, preferably including water treatment, wastewater treatment, water distribution, or wastewater collection systems equipment and facilities.

**CERTIFICATES, LICENSES, REGISTRATIONS:**

Possession of the category of a valid California Driver's license required by the State

Department of Motor Vehicles to perform the essential duties of the position. Continued maintenance of a valid driver's license, insurability, and compliance with established District vehicle operation standards are a condition of continuing employment.

Possession and maintenance of a CA Grade 1 Water Treatment Operator's Certificate by the California Department of Public Health, is required within 18 months of hire date.

Immediately upon hire, the OIT must file an OIT application with the State Water Resources Control Board (SWRCB) Office of Operator Certification for a Grade 1 OIT certificate, signed by the District's Chief Plant Operator.

Possession and maintenance of a CA Grade I Wastewater Treatment Certificate by the State Water Resources Control Board within 24 months of entering this position is required.

Promotion to Plant Operator I is at the discretion of the District, position availability, and is not automatic upon obtaining required certifications.

**PHYSICAL DEMANDS:**

The physical demands described here are representative of those that must be met by an employee to successfully perform the essential functions of this job.

While performing the duties of this job, the employee is regularly required to stoop, kneel, crouch, or crawl. The employee frequently is required to stand, walk, sit, and climb or balance. The employee is occasionally required to use hands to finger, handle, or feel objects, tools, or controls; reach with hands and arms; talk or hear; and taste or smell.

The employee must occasionally lift and/or move up to 50 pounds. Specific vision abilities required by this job include close vision, distance vision, color vision to interpret a variety of colors on graphical and computer displays, peripheral vision, depth perception, and the ability to adjust focus.

**WORK ENVIRONMENT:**

The work environment characteristics described here are representative of those an employee encounters while performing the essential functions of this job. Reasonable accommodations may be made to enable individuals with disabilities to perform the essential functions.

While performing the duties of this job, the employee is frequently exposed to wet and/or humid conditions. The employee occasionally works near moving mechanical parts; in high, precarious places, and in outside weather conditions and is occasionally exposed to toxic or caustic chemicals, extreme cold, extreme heat, and vibration. The noise level in the work environment is usually loud.

**COMMENTS:**

Employees appointed to positions in this class are required to be neatly groomed as

needed to wear respiratory protection or other safety equipment. Ability to wear and use SCBA units as regulated by Cal/OSHA.

# RANCHO MURIETA COMMUNITY SERVICES DISTRICT

## PLANT OPERATOR I

---

DEPARTMENT: WATER/WASTEWATER

FLSA OVERTIME STATUS: NON-EXEMPT

BARGAINING UNIT: OPERATING ENGINEERS LOCAL 3

APPROVED BY BOARD OF DIRECTORS – 42/46/09 June 21, 2023

---

**SUMMARY:** To assist with or control the operation, and maintenance of District water and wastewater treatment and pumping facilities, machinery, equipment, structures, and grounds, and to perform other related duties as required.

**SUPERVISION:** Receives direct supervision from the Chief Plant Operator.

**ESSENTIAL DUTIES AND RESPONSIBILITIES** include the following. Other duties may be assigned.

- Assists or controls the operation of water and wastewater treatment and pumping facilities to achieve proper processing of wastewater and disposal of sludge and effluent within mandated operating requirements; assists with the monitoring of treatment processes and enters data in appropriate logs;
- assists or controls with starting and operating plant processes, chemical systems, and power generators in a safe and orderly manner; keeps machinery, equipment, structures, piping, work areas, grounds, and landscaped areas in a clean and orderly condition;
- assists others with grounds, machinery and equipment maintenance, repair, and overhaul;
- assists with the transport and storage of hazardous chemicals and gases; inspects pumping stations, control equipment, facilities, and grounds for needed maintenance and repairs and unusual operating conditions;
- assists in the operation, repair, and maintenance of related storm and drainage systems, lifting and pump stations and collection systems;
- learns how to perform basic operating procedures; learns sample collection and basic laboratory testing and analytical procedures; work in or around hazardous

electrical panels and equipment;

- learns and trains in proper operating and safety procedures for normal operations, chlorine leaks and other emergencies.

**DISTINGUISHING CHARACTERISTICS:**

Incumbents are expected to perform plant and facility operations and maintenance assignments in the area for which they are certified with minimum guidance and supervision. Incumbents work in a training status under supervision of a qualified, certified and experienced operator until necessary certifications are achieved in the area they are gaining experience for certification.

**QUALIFICATION REQUIREMENTS:**

To perform this job successfully, an individual must be able to perform each essential duty satisfactorily. The requirements listed below are representative of the knowledge, skill, and/or ability required.

The ability to learn and apply the practices, procedures, techniques, regulations, and laws pertaining to water and wastewater treatment plant and pumping facilities operations and maintenance, and the ability to learn to operate and perform routine maintenance on treatment plant equipment and related facilities. Learn to read and interpret a variety of meters, gages, recording charts, and mechanical and piping diagrams. Have the ability to perform a variety of skilled and semiskilled maintenance and repair work. Understand and carry out oral and written instructions. Maintain and update records and logs. Work unusual shifts, weekends, evenings, and holidays when required. Establish and maintain cooperative working relationships.

**EDUCATION AND/OR EXPERIENCE:**

Any combination of training and experience, which would likely provide the required knowledge and ability, is qualifying. A typical way to obtain this knowledge and ability would be either:

Minimum Education: High School diploma and/or equivalent.

One year of general work in water treatment and/or wastewater treatment facilities.

**CERTIFICATES, LICENSES, REGISTRATIONS:**

Possession of the category of California Driver's license required by the State Department of Motor Vehicles to perform the essential duties of the position. Continued maintenance of a valid driver's license, insurability, and compliance with established District vehicle operation standards are a condition of continuing employment.

The Plant Operator 1 requires possession of either a CA Grade 1 Wastewater Plant



Operator's Certificate by the California State Water Resources Control Board (SWRCB);  
*or*

CA Grade 1 Operator's certificate issued by the SWRCB, Division of Drinking Water at the time of hire, and the ability to obtain the other outstanding certification within 18 months of entering the position.

**PHYSICAL DEMANDS:**

The physical demands described here are representative of those that must be met by an employee to successfully perform the essential functions of this job.

While performing the duties of this job, the employee is regularly required to stoop, kneel, crouch, or crawl. The employee frequently is required to stand, walk, sit, and climb or balance. The employee is occasionally required to use hands to finger, handle, or feel objects, tools, or controls; reach with hands and arms; talk or hear; and taste or smell.

The employee must occasionally lift and/or move up to ~~75~~50 pounds. Specific vision abilities required by this job include close vision, distance vision, color vision, peripheral vision, depth perception, and the ability to adjust focus.

**WORK ENVIRONMENT:**

The work environment characteristics described here are representative of those an employee encounters while performing the essential functions of this job. Reasonable accommodations may be made to enable individuals with disabilities to perform the essential functions.

While performing the duties of this job, the employee is frequently exposed to wet and/or humid conditions. The employee occasionally works near moving mechanical parts; in high, precarious places, and in outside weather conditions and is occasionally exposed to toxic or caustic chemicals, extreme cold, extreme heat, and vibration.

The noise level in the work environment is usually loud.

**COMMENTS:**

Employees appointed to positions in this class are required to be neatly groomed as needed to wear respiratory protection or other safety equipment.

# RANCHO MURIETA COMMUNITY SERVICES DISTRICT

## PLANT OPERATOR I

---

DEPARTMENT: WATER/WASTEWATER

FLSA OVERTIME STATUS: NON-EXEMPT

BARGAINING UNIT: OPERATING ENGINEERS LOCAL 3

APPROVED BY BOARD OF DIRECTORS – June 21, 2023

---

**SUMMARY:** To assist with or control the operation, and maintenance of District water and wastewater treatment and pumping facilities, machinery, equipment, structures, and grounds, and to perform other related duties as required.

**SUPERVISION:** Receives direct supervision from the Chief Plant Operator.

**ESSENTIAL DUTIES AND RESPONSIBILITIES** include the following. Other duties may be assigned.

- Assists or controls the operation of water and wastewater treatment and pumping facilities to achieve proper processing of wastewater and disposal of sludge and effluent within mandated operating requirements; assists with the monitoring of treatment processes and enters data in appropriate logs;
- assists or controls with starting and operating plant processes, chemical systems, and power generators in a safe and orderly manner; keeps machinery, equipment, structures, piping, work areas, grounds, and landscaped areas in a clean and orderly condition;
- assists others with grounds, machinery and equipment maintenance, repair, and overhaul;
- assists with the transport and storage of hazardous chemicals and gases; inspects pumping stations, control equipment, facilities, and grounds for needed maintenance and repairs and unusual operating conditions;
- assists in the operation, repair, and maintenance of related storm and drainage systems, lifting and pump stations and collection systems;
- learns how to perform basic operating procedures; learns sample collection and basic laboratory testing and analytical procedures; work in or around hazardous electrical panels and equipment;

- learns and trains in proper operating and safety procedures for normal operations, chlorine leaks and other emergencies.

**DISTINGUISHING CHARACTERISTICS:**

Incumbents are expected to perform plant and facility operations and maintenance assignments in the area for which they are certified with minimum guidance and supervision. Incumbents work in a training status under supervision of a qualified, certified and experienced operator until necessary certifications are achieved in the area they are gaining experience for certification.

**QUALIFICATION REQUIREMENTS:**

To perform this job successfully, an individual must be able to perform each essential duty satisfactorily. The requirements listed below are representative of the knowledge, skill, and/or ability required.

The ability to learn and apply the practices, procedures, techniques, regulations, and laws pertaining to water and wastewater treatment plant and pumping facilities operations and maintenance, and the ability to learn to operate and perform routine maintenance on treatment plant equipment and related facilities. Learn to read and interpret a variety of meters, gages, recording charts, and mechanical and piping diagrams. Have the ability to perform a variety of skilled and semiskilled maintenance and repair work. Understand and carry out oral and written instructions. Maintain and update records and logs. Work unusual shifts, weekends, evenings, and holidays when required. Establish and maintain cooperative working relationships.

**EDUCATION AND/OR EXPERIENCE:**

Any combination of training and experience, which would likely provide the required knowledge and ability, is qualifying. A typical way to obtain this knowledge and ability would be either:

Minimum Education: High School diploma and/or equivalent.

One year of general work in water treatment and/or wastewater treatment facilities.

**CERTIFICATES, LICENSES, REGISTRATIONS:**

Possession of the category of California Driver's license required by the State Department of Motor Vehicles to perform the essential duties of the position. Continued maintenance of a valid driver's license, insurability, and compliance with established District vehicle operation standards are a condition of continuing employment.

The Plant Operator 1 requires possession of either a CA Grade 1 Wastewater Plant Operator's Certificate by the California State Water Resources Control Board (SWRCB);  
*or*

CA Grade 1 Operator's certificate issued by the SWRCB, Division of Drinking Water at the time of hire, and the ability to obtain the other outstanding certification within 18 months of entering the position.

**PHYSICAL DEMANDS:**

The physical demands described here are representative of those that must be met by an employee to successfully perform the essential functions of this job.

While performing the duties of this job, the employee is regularly required to stoop, kneel, crouch, or crawl. The employee frequently is required to stand, walk, sit, and climb or balance. The employee is occasionally required to use hands to finger, handle, or feel objects, tools, or controls; reach with hands and arms; talk or hear; and taste or smell.

The employee must occasionally lift and/or move up to 50 pounds. Specific vision abilities required by this job include close vision, distance vision, color vision, peripheral vision, depth perception, and the ability to adjust focus.

**WORK ENVIRONMENT:**

The work environment characteristics described here are representative of those an employee encounters while performing the essential functions of this job. Reasonable accommodations may be made to enable individuals with disabilities to perform the essential functions.

While performing the duties of this job, the employee is frequently exposed to wet and/or humid conditions. The employee occasionally works near moving mechanical parts; in high, precarious places, and in outside weather conditions and is occasionally exposed to toxic or caustic chemicals, extreme cold, extreme heat, and vibration.

The noise level in the work environment is usually loud.

**COMMENTS:**

Employees appointed to positions in this class are required to be neatly groomed as needed to wear respiratory protection or other safety equipment.

## RANCHO MURIETA COMMUNITY SERVICES DISTRICT

### PLANT OPERATOR II

---

DEPARTMENT: WATER/WASTEWATER

FLSA OVERTIME STATUS: NON-EXEMPT

BARGAINING UNIT: OPERATING ENGINEERS LOCAL 3

---

APPROVED BY BOARD OF DIRECTORS - ~~02/16/05~~ June 21, 2023

---

**SUMMARY:** To operate, maintain, and control the District's water and wastewater treatment and pumping facilities; to regulate influent, and effluent flows within the system; to do basic laboratory testing and sample collection; to check operations and monitor equipment for proper functioning; to perform regular maintenance of District water and wastewater treatment and pumping facilities, machinery, equipment, structures, and grounds; and to perform other related duties as required.

**SUPERVISION:** Receives direct supervision from the Chief Plant Operator.

**ESSENTIAL DUTIES AND RESPONSIBILITIES** include the following. Other duties may be assigned.

- Controls the operation of water and wastewater treatment and pumping facilities to achieve proper processing of water and wastewater and disposal of sludge and effluent within mandated operating requirements;
- monitors treatment processes and enters data in appropriate logs; starts and controls plant processes, chemical systems, and power generators in a safe and orderly manner;
- keeps machinery, equipment, structures, piping, work areas, grounds, and landscaped areas in a clean and orderly condition;
- assists others with complex machinery and equipment maintenance, repair, and overhaul; assists with the transport and storage of hazardous chemicals and gases;
- assists in the operation, repair, and maintenance of related storm and drainage systems, lifting and pump stations and collection systems;
- inspects pumping stations, control equipment, facilities, and grounds for needed maintenance and repairs and unusual operating conditions;
- performs basic operating procedures without close guidance and supervision;

Z:\Dobby\Admin Asst\Job Descriptions\2005\Plant Operator-2.doc

- performs basic sample collection and basic laboratory testing and analytical procedures.
- Responds and resolves customer complaints regarding water quality and/or pressure.

**Formatted:** Not Expanded by / Condensed by

**Formatted:** Left, Line spacing: single, No bullets or numbering, Hyphenate, Tab stops: Not at -0.5"

**DISTINGUISHING CHARACTERISTICS:**

This is the journey level in the Plant Operator series. Incumbents are expected to perform plant and facility operations and maintenance assignments with minimum guidance and supervision.

**QUALIFICATION REQUIREMENTS:**

To perform this job successfully, an individual must be able to perform each essential duty satisfactorily. The requirements listed below are representative of the knowledge, skill, and/or ability required.

The ability to learn and apply the practices, procedures, techniques, regulations, and laws pertaining to water and wastewater treatment plant and pumping facilities operations and maintenance, and the ability to learn to operate and perform routine maintenance on treatment plant equipment and related facilities. Learn to read and interpret a variety of meters, gages, recording charts, and mechanical and piping diagrams. Have the ability to perform a variety of skilled and semiskilled maintenance and repair work. Understand and carry out oral and written instructions. Maintain and update records and logs. Work unusual shifts, weekends, evenings, and holidays when required. Establish and maintain cooperative working relationships.

**EDUCATION AND/OR EXPERIENCE:**

Any combination of training and experience, which would likely provide the required knowledge and ability, is qualifying. A typical way to obtain this knowledge and ability would be either:

Minimum Education: High School diploma and/or equivalent.

Two years of experience as a Plant Operator I with Rancho Murieta Community Services District; *or*

Two years of increasingly responsible work experience in the operation and maintenance of water and wastewater treatment and pumping facilities.



**CERTIFICATES, LICENSES, REGISTRATIONS:**

Possession of the category of California Driver's license required by the State Department of Motor Vehicles to perform the essential duties of the position. Continued maintenance of a valid driver's license, insurability, and compliance with established District vehicle operation standards are a condition of continuing employment.

Possession and maintenance of a Grade 2 Wastewater Plant Operator's Certificate of Competence issued by the California State Water Resources Control Board within 18 months of entering this position is required, and;

Possession and maintenance of a Grade 2 Water Treatment Operator's Certificate required by the State Water Resources Control Board (SWRCB), Division of Drinking ~~Water~~Water within 18 months of entering this position is required.

**PHYSICAL DEMANDS:**

The physical demands described here are representative of those that must be met by an employee to successfully perform the essential functions of this job.

While performing the duties of this job, the employee is regularly required to stoop, kneel, crouch, or crawl. The employee frequently is required to stand, walk, sit, and climb or balance. The employee is occasionally required to use hands to finger, handle, or feel objects, tools, or controls; reach with hands and arms; talk or hear; and taste or smell.

The employee must occasionally lift and/or move up to ~~75~~50 pounds. Specific vision abilities required by this job include close vision, distance vision, color vision, peripheral vision, depth perception, and the ability to adjust focus.

**WORK ENVIRONMENT:**

The work environment characteristics described here are representative of those an employee encounters while performing the essential functions of this job. Reasonable accommodations may be made to enable individuals with disabilities to perform the essential functions.

While performing the duties of this job, the employee is frequently exposed to wet and/or humid conditions. The employee occasionally works near moving mechanical parts; in high, precarious places; and in outside weather conditions and is occasionally exposed to toxic or caustic chemicals, extreme cold, extreme heat, and vibration, risk of electrical shock.

The noise level in the work environment is usually loud.

**COMMENTS:**

Employees appointed to positions in this class are required to be neatly groomed as needed to wear respiratory protection or other safety equipment.

Z:\Dobby\Admin Asst\Job Descriptions\2005\Plant Operator-2.doc

# RANCHO MURIETA COMMUNITY SERVICES DISTRICT

## PLANT OPERATOR II

---

DEPARTMENT: WATER/WASTEWATER

FLSA OVERTIME STATUS: NON-EXEMPT

BARGAINING UNIT: OPERATING ENGINEERS LOCAL 3

APPROVED BY BOARD OF DIRECTORS - June 21, 2023

---

**SUMMARY:** To operate, maintain, and control the District's water and wastewater treatment and pumping facilities; to regulate influent, and effluent flows within the system; to do basic laboratory testing and sample collection; to check operations and monitor equipment for proper functioning; to perform regular maintenance of District water and wastewater treatment and pumping facilities, machinery, equipment, structures, and grounds; and to perform other related duties as required.

**SUPERVISION:** Receives direct supervision from the Chief Plant Operator.

**ESSENTIAL DUTIES AND RESPONSIBILITIES** include the following. Other duties may be assigned.

- Controls the operation of water and wastewater treatment and pumping facilities to achieve proper processing of water and wastewater and disposal of sludge and effluent within mandated operating requirements;
- monitors treatment processes and enters data in appropriate logs; starts and controls plant processes, chemical systems, and power generators in a safe and orderly manner;
- keeps machinery, equipment, structures, piping, work areas, grounds, and landscaped areas in a clean and orderly condition;
- assists others with complex machinery and equipment maintenance, repair, and overhaul; assists with the transport and storage of hazardous chemicals and gases;
- assists in the operation, repair, and maintenance of related storm and drainage systems, lifting and pump stations and collection systems;
- inspects pumping stations, control equipment, facilities, and grounds for needed maintenance and repairs and unusual operating conditions;
- performs basic operating procedures without close guidance and supervision;

- performs basic sample collection and basic laboratory testing and analytical procedures.
- Responds and resolves customer complaints regarding water quality and/or pressure.

**DISTINGUISHING CHARACTERISTICS:**

This is the journey level in the Plant Operator series. Incumbents are expected to perform plant and facility operations and maintenance assignments with minimum guidance and supervision.

**QUALIFICATION REQUIREMENTS:**

To perform this job successfully, an individual must be able to perform each essential duty satisfactorily. The requirements listed below are representative of the knowledge, skill, and/or ability required.

The ability to learn and apply the practices, procedures, techniques, regulations, and laws pertaining to water and wastewater treatment plant and pumping facilities operations and maintenance, and the ability to learn to operate and perform routine maintenance on treatment plant equipment and related facilities. Learn to read and interpret a variety of meters, gages, recording charts, and mechanical and piping diagrams. Have the ability to perform a variety of skilled and semiskilled maintenance and repair work. Understand and carry out oral and written instructions. Maintain and update records and logs. Work unusual shifts, weekends, evenings, and holidays when required. Establish and maintain cooperative working relationships.

**EDUCATION AND/OR EXPERIENCE:**

Any combination of training and experience, which would likely provide the required knowledge and ability, is qualifying. A typical way to obtain this knowledge and ability would be either:

Minimum Education: High School diploma and/or equivalent.

Two years of experience as a Plant Operator I with Rancho Murieta Community Services District; *or*

Two years of increasingly responsible work experience in the operation and maintenance of water and wastewater treatment and pumping facilities.

**CERTIFICATES, LICENSES, REGISTRATIONS:**

Possession of the category of California Driver's license required by the State Department of Motor Vehicles to perform the essential duties of the position. Continued maintenance of a valid driver's license, insurability, and compliance with established District vehicle operation standards are a condition of continuing employment.

Possession and maintenance of a Grade 2 Wastewater Plant Operator's Certificate of Competence issued by the California State Water Resources Control Board within 18 months of entering this position is required, and;

Possession and maintenance of a Grade 2 Water Treatment Operator's Certificate required by the State Water Resources Control Board (SWRCB), Division of Drinking Water within 18 months of entering this position is required.

**PHYSICAL DEMANDS:**

The physical demands described here are representative of those that must be met by an employee to successfully perform the essential functions of this job.

While performing the duties of this job, the employee is regularly required to stoop, kneel, crouch, or crawl. The employee frequently is required to stand, walk, sit, and climb or balance. The employee is occasionally required to use hands to finger, handle, or feel objects, tools, or controls; reach with hands and arms; talk or hear; and taste or smell.

The employee must occasionally lift and/or move up to 50 pounds. Specific vision abilities required by this job include close vision, distance vision, color vision, peripheral vision, depth perception, and the ability to adjust focus.

**WORK ENVIRONMENT:**

The work environment characteristics described here are representative of those an employee encounters while performing the essential functions of this job. Reasonable accommodations may be made to enable individuals with disabilities to perform the essential functions.

While performing the duties of this job, the employee is frequently exposed to wet and/or humid conditions. The employee occasionally works near moving mechanical parts; in high, precarious places; and in outside weather conditions and is occasionally exposed to toxic or caustic chemicals, extreme cold, extreme heat, and vibration, risk of electrical shock.

The noise level in the work environment is usually loud.

**COMMENTS:**

Employees appointed to positions in this class are required to be neatly groomed as needed to wear respiratory protection or other safety equipment.

## RANCHO MURIETA COMMUNITY SERVICES DISTRICT

### PLANT OPERATOR III

---

DEPARTMENT: WATER/WASTEWATER

FLSA OVERTIME STATUS: NON-EXEMPT

BARGAINING UNIT: OPERATING ENGINEERS LOCAL 3

---

APPROVED BY BOARD OF DIRECTORS - ~~02/16/05~~ June 21, 2023

---

**SUMMARY:** Responsible for operations and maintenance of water and wastewater treatment plants during an assigned period; to perform a variety of operations, control, and maintenance functions at the District's water and wastewater treatment plant facilities; to perform basic laboratory testing and sample collection; and to perform other job related work as required.

**SUPERVISION:** Receives direct supervision from the Chief Plant Operator.

**ESSENTIAL DUTIES AND RESPONSIBILITIES** include the following. Other duties may be assigned.

- Monitors the operation of water and wastewater treatment plant pumps, motors, and other equipment; reads gauges, dials, and other instruments that record plant operations; enters data into computer; maintains shift logs;
- makes visual inspections of plant operations, insuring that operational problems have been located and corrected;
- interprets operating data, observes variations in operating conditions and makes the more complex operating adjustments;
- operates valves and controls to feed chemicals; inspects, cleans, maintains and replaces pumps, motors, valves, filters, meters, and related equipment; performs required preventive maintenance and repairs; collects a variety of samples for laboratory tests; standardizes and calibrates instrumentation, analyzers and chemical feed pumps;
- assists in the operation, repair, and maintenance of related storm and drainage systems, lifting and pump stations, collection systems and grounds into the District;
- performs a variety of general and grounds maintenance in and around plant facilities;

Z:\Debbby\Admin-Assst\Job-Descriptions\2005\Plant-Operator-3.doc

**Formatted:** Not Expanded by / Condensed by  
**Formatted:** Left, Line spacing: single, No bullets or numbering, Hyphenate, Tab stops: Not at -0.5"

- assists the Chief Plant Operator in formulating and implementing safe work practices; assists in the supervision and training of less experienced personnel;
- responds to customer questions and complaints.

**DISTINGUISHING CHARACTERISTICS:**

This is the advanced working level in the Plant Operator series. Incumbents are expected to perform the more difficult plant and facility operations and maintenance assignments with minimum guidance and supervision; to provide work direction and assist the Chief Plant Operator; to have daily responsibility for operations and maintenance; to conduct special studies and investigations related to water and wastewater treatment plant construction and maintenance.

**QUALIFICATION REQUIREMENTS:**

To perform this job successfully, an individual must be able to perform each essential duty satisfactorily. The requirements listed below are representative of the knowledge, skill, and/or ability required.

The ability to perform a wide range of operations, repair, and maintenance work at water and wastewater treatment facilities. Provide work direction, scheduling, and lead supervision for other staff. Maintain responsibility for operations and maintenance at assigned facilities. Read and interpret gauges and other recording devices reflecting water and wastewater treatment plant operations and make operating adjustments based upon recorded data. Take water, wastewater and sludge samples and perform basic on-site laboratory tests. Diagnose a variety of operating problems and take effective corrective actions. Read and write at the level required for successful job performance. Maintain logs, records, reports, and charts. Provide training for less experienced staff. Establish and maintain cooperative working relationships.

**EDUCATION AND/OR EXPERIENCE:**

Any combination of training and experience, which would provide the required knowledge and ability, is qualifying. A typical way to obtain the requisite knowledge and ability would be:

Minimum Education: High School diploma and/or equivalent.

Two years of experience as a Plant Operator II with Rancho Murieta Community Services District; or



Three years of increasingly responsible work experience in the operation and maintenance of water and wastewater treatment and pumping facilities.

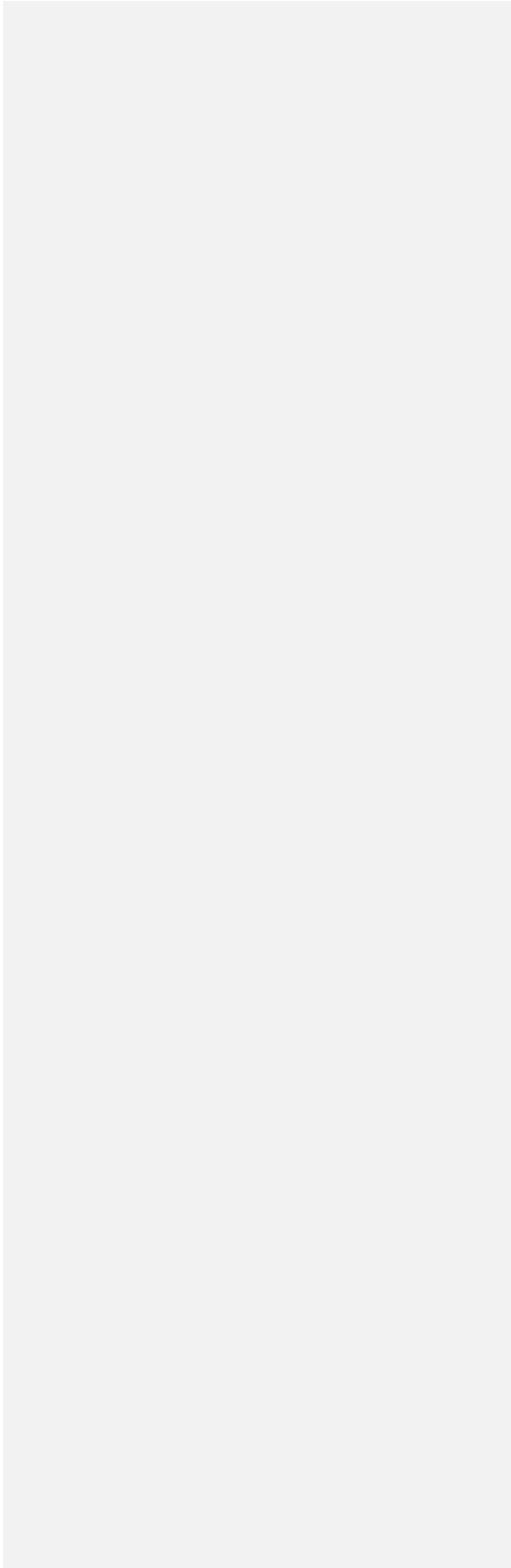

**CERTIFICATES, LICENSES, REGISTRATIONS:**

Possession of the category of California Driver's license required by the State Department of Motor Vehicles to perform the essential duties of the position. Continued maintenance of a valid driver's license, insurability, and compliance with established District vehicle operation standards are conditions of continuing employment.

Possession and maintenance of a Grade 3 Wastewater Plant Operator's Certificate of Competence issued by the California State Water Resources Control Board within 18 months of entering this position is required, and;

Possession and maintenance of a Grade 3 Water Treatment Operator's Certificate required by the State Water Resources Control Board (SWRCB), Division of Drinking ~~Water within~~ Water within 18 months of entering this position is required.

**PHYSICAL DEMANDS:**

The physical demands described here are representative of those that must be met by an employee to successfully perform the essential functions of this job.

While performing the duties of this job, the employee is frequently required to stand; walk; sit; climb or balance; and stoop, kneel, crouch, or crawl. The employee is occasionally required to use hands to finger, handle, or feel objects, tools, or controls; reach with hands and arms; and talk or hear.

The employee must occasionally lift and/or move up to ~~75~~50 pounds. Specific vision abilities required by this job include close vision, distance vision, color vision, peripheral vision, depth perception, and the ability to adjust focus.

**WORK ENVIRONMENT:**

The work environment characteristics described here are representative of those an employee encounters while performing the essential functions of this job. Reasonable accommodations may be made to enable individuals with disabilities to perform the essential functions.

While performing the duties of this job, the employee occasionally works near moving mechanical parts; in high, precarious places; and in outside weather conditions and is occasionally exposed to wet and/or humid conditions, fumes or airborne particles, toxic or caustic chemicals, extreme cold, extreme heat, and vibration, risk of electrical shock.

The noise level in the work environment is usually moderate.

**COMMENTS:**

Employees appointed to positions in this class are required to be neatly groomed as needed to wear respiratory protection or other safety equipment.

Z:\Debbie\Admin-Assist-Job-Descriptions\2005\Plant-Operator-3.doc

# RANCHO MURIETA COMMUNITY SERVICES DISTRICT

## PLANT OPERATOR III

---

DEPARTMENT: WATER/WASTEWATER

FLSA OVERTIME STATUS: NON-EXEMPT

BARGAINING UNIT: OPERATING ENGINEERS LOCAL 3

APPROVED BY BOARD OF DIRECTORS - June 21, 2023

---

**SUMMARY:** Responsible for operations and maintenance of water and wastewater treatment plants during an assigned period; to perform a variety of operations, control, and maintenance functions at the District's water and wastewater treatment plant facilities; to perform basic laboratory testing and sample collection; and to perform other job related work as required.

**SUPERVISION:** Receives direct supervision from the Chief Plant Operator.

**ESSENTIAL DUTIES AND RESPONSIBILITIES** include the following. Other duties may be assigned.

- Monitors the operation of water and wastewater treatment plant pumps, motors, and other equipment; reads gauges, dials, and other instruments that record plant operations; enters data into computer; maintains shift logs;
- makes visual inspections of plant operations, insuring that operational problems have been located and corrected;
- interprets operating data, observes variations in operating conditions and makes the more complex operating adjustments;
- operates valves and controls to feed chemicals; inspects, cleans, maintains and replaces pumps, motors, valves, filters, meters, and related equipment; performs required preventive maintenance and repairs; collects a variety of samples for laboratory tests; standardizes and calibrates instrumentation, analyzers and chemical feed pumps;
- assists in the operation, repair, and maintenance of related storm and drainage systems, lifting and pump stations, collection systems and grounds into the District;
- performs a variety of general and grounds maintenance in and around plant facilities;

- assists the Chief Plant Operator in formulating and implementing safe work practices; assists in the supervision and training of less experienced personnel;
- responds to customer questions and complaints.

**DISTINGUISHING CHARACTERISTICS:**

This is the advanced working level in the Plant Operator series. Incumbents are expected to perform the more difficult plant and facility operations and maintenance assignments with minimum guidance and supervision; to provide work direction and assist the Chief Plant Operator; to have daily responsibility for operations and maintenance; to conduct special studies and investigations related to water and wastewater treatment plant construction and maintenance.

**QUALIFICATION REQUIREMENTS:**

To perform this job successfully, an individual must be able to perform each essential duty satisfactorily. The requirements listed below are representative of the knowledge, skill, and/or ability required.

The ability to perform a wide range of operations, repair, and maintenance work at water and wastewater treatment facilities. Provide work direction, scheduling, and lead supervision for other staff. Maintain responsibility for operations and maintenance at assigned facilities. Read and interpret gauges and other recording devices reflecting water and wastewater treatment plant operations and make operating adjustments based upon recorded data. Take water, wastewater and sludge samples and perform basic on-site laboratory tests. Diagnose a variety of operating problems and take effective corrective actions. Read and write at the level required for successful job performance. Maintain logs, records, reports, and charts. Provide training for less experienced staff. Establish and maintain cooperative working relationships.

**EDUCATION AND/OR EXPERIENCE:**

Any combination of training and experience, which would provide the required knowledge and ability, is qualifying. A typical way to obtain the requisite knowledge and ability would be:

Minimum Education: High School diploma and/or equivalent.

Two years of experience as a Plant Operator II with Rancho Murieta Community Services District; *or*

Three years of increasingly responsible work experience in the operation and maintenance of water and wastewater treatment and pumping facilities.

**CERTIFICATES, LICENSES, REGISTRATIONS:**

Possession of the category of California Driver's license required by the State Department of Motor Vehicles to perform the essential duties of the position. Continued maintenance of a valid driver's license, insurability, and compliance with established District vehicle operation standards are conditions of continuing employment.

Possession and maintenance of a Grade 3 Wastewater Plant Operator's Certificate of Competence issued by the California State Water Resources Control Board within 18 months of entering this position is required, and;

Possession and maintenance of a Grade 3 Water Treatment Operator's Certificate required by the State Water Resources Control Board (SWRCB), Division of Drinking Water within 18 months of entering this position is required.

**PHYSICAL DEMANDS:**

The physical demands described here are representative of those that must be met by an employee to successfully perform the essential functions of this job.

While performing the duties of this job, the employee is frequently required to stand; walk; sit; climb or balance; and stoop, kneel, crouch, or crawl. The employee is occasionally required to use hands to finger, handle, or feel objects, tools, or controls; reach with hands and arms; and talk or hear.

The employee must occasionally lift and/or move up to 50 pounds. Specific vision abilities required by this job include close vision, distance vision, color vision, peripheral vision, depth perception, and the ability to adjust focus.

**WORK ENVIRONMENT:**

The work environment characteristics described here are representative of those an employee encounters while performing the essential functions of this job. Reasonable accommodations may be made to enable individuals with disabilities to perform the essential functions.

While performing the duties of this job, the employee occasionally works near moving mechanical parts; in high, precarious places; and in outside weather conditions and is occasionally exposed to wet and/or humid conditions, fumes or airborne particles, toxic or caustic chemicals, extreme cold, extreme heat, and vibration, risk of electrical shock.

The noise level in the work environment is usually moderate.

**COMMENTS:**

Employees appointed to positions in this class are required to be neatly groomed as needed to wear respiratory protection or other safety equipment.

# RANCHO MURIETA COMMUNITY SERVICES DISTRICT

## CHIEF PLANT OPERATOR

---

DEPARTMENT: WATER/WASTEWATER

FLSA OVERTIME STATUS: NON-EXEMPT

BARGAINING UNIT: N/A

APPROVED BY BOARD OF DIRECTORS – ~~05/17/06~~ June 21, 2023

---

**SUMMARY:** Responsible for the daily supervision of staff to handle operations and maintenance of water and wastewater treatment plants, reservoirs, lift stations, dams, equipment and drainage facilities; to provide work scheduling and lead direction for other plant operator and maintenance staff; to oversee laboratory testing including such duties as sample collection and monitoring for compliance; monitors projects; provides technical assistance; responds to problems and emergencies; and to perform other job related work as required.

**SUPERVISION:** Receives general supervision from the Director of Field Operations. Provides direct supervision over Plant Operators and the Equipment Mechanic.

**ESSENTIAL DUTIES AND RESPONSIBILITIES** include the following. Other duties may be assigned.

- Supervises and oversees the operations and maintenance of water and wastewater treatment plants, reservoirs, lift stations, labs, lakes, dams, and drainage facilities;
- Provides work direction and scheduling for other staff; makes visual inspections of plant operations, insuring that operational problems have been located and corrected;
- Evaluates work methods, procedures, staff and equipment and recommends improvements, procedures, methods to improve efficiency and process capabilities;
- Plans, schedules and implements required routine, preventive, and emergency maintenance and repairs. Plans, schedules, and implements capital improvement projects;
- Responsible for in-house laboratory activities, maintains laboratory certification with Environmental License Accreditation Program, and coordinates and sends out a variety of samples for laboratory tests to comply with appropriate regulatory requirements and to ensure water quality;
- Maintains operations records and inspections and logs; updates information for



reports; analyzes records and reports to optimize efficiency and effectiveness;

- Assists with the preparation of annual budget and estimates of future district water needs; consults with engineering, health, environmental, suppliers, and others on changes in operations;
- Prepares and submits reports to Federal, State, County and local agencies;
- Requisitions and maintains an inventory of all equipment and supplies necessary to carry out system operations;
- Assists with employee evaluations and hiring process; assists in formulating and implementing safe work practices; provides on-the-job training for less experienced personnel;
- Identifies, develops and conducts safety and prevention training of staff in response to regulatory compliance and to maximize process, efficiency, operations, service and quality; and other related duties as assigned.

**DISTINGUISHING CHARACTERISTICS:**

This is the working supervisory level in the Plant Operator series. Incumbents are expected to perform the more difficult plant and facility operations and maintenance assignments with limited guidance and supervision; to provide work direction and scheduling for other staff; to have daily responsibility for operations and maintenance; conduct special studies and investigations related to water and wastewater treatment plant and distribution system construction, maintenance and operations.

**QUALIFICATION REQUIREMENTS:**

To perform this job successfully, an individual must be able to perform each essential duty satisfactorily. The requirements listed below are representative of the knowledge, skill, and/or ability required.

**Skills In:** computers, computer applications and software.

Ability to supervise personnel in a wide range of operations, repair, and maintenance work at water and wastewater treatment facilities. Develop, implement and maintain comprehensive asset management and preventative maintenance program. Maintain responsibility for operations and maintenance at assigned facilities. Read and interpret gauges and other recording devices reflecting water and wastewater treatment plant operations and make operating adjustments based upon recorded data. Monitor and manage the progress of multiple projects. Diagnose a variety of operating problems and take effective corrective actions. Communicate clearly and precisely verbally and written. Maintain logs, charts, records, reports, and budgets. Mentor and train less experienced staff. Establish and maintain cooperative working relationships. Respond to off hour emergencies and call outs.

**EDUCATION AND/OR EXPERIENCE:**

Any combination of training and experience which would provide the required knowledge and ability is qualifying. A typical way to obtain the requisite knowledge and ability would be:

Minimum Education: High School diploma and/or equivalent.

Two years of experience as a Plant Operator III with Rancho Murieta Community Services District; *or*

Three years of increasingly responsible work experience in the operation and maintenance of water and wastewater treatment and pumping facilities.

**CERTIFICATES, LICENSES, REGISTRATIONS:**

Possession of the category of California Driver's license required by the State Department of Motor Vehicles to perform the essential duties of the position. Continued maintenance of a valid driver's license, insurability, and compliance with established District vehicle operation standards are conditions of continuing employment.

Possession and maintenance of a Grade 3 Wastewater Plant Operator's Certificate of Competence issued by the California State Water Resources Control Board within 18 months of entering this position is required, and;

Possession and maintenance of a Grade 3 Water Treatment Operator's Certificate required by the California Department of Health Services within 18 months of entering this position is required, and;

Possession of a Grade 1 Laboratory Certificate issued by either the CWEA or the AWWA.

Possession of Grade 2 or higher Water Distribution Operator certificate is required within 18 months of hire.

Continued certification advancement is expected.

**PHYSICAL DEMANDS:**

The physical demands described here are representative of those that must be met by an employee to successfully perform the essential functions of this job.

While performing the duties of this job, the employee is frequently required to stand; walk; sit; climb or balance; and stoop, kneel, crouch, or crawl. The employee is occasionally required to use hands to finger, handle, or feel objects, tools, or controls; reach with hands and arms; and talk or hear.

The employee must occasionally lift and/or move up to ~~75~~50 pounds. Specific vision

abilities required by this job include close vision, distance vision, color vision, peripheral vision, depth perception, and the ability to adjust focus.

**WORK ENVIRONMENT:**

The work environment characteristics described here are representative of those an employee encounters while performing the essential functions of this job. Reasonable accommodations may be made to enable individuals with disabilities to perform the essential functions.

While performing the duties of this job, the employee occasionally works near moving mechanical parts; in high, precarious places; and in outside weather conditions and is occasionally exposed to water and wastewater borne viruses and pathogens wet and/or humid conditions, fumes or airborne particles, toxic or caustic chemicals, extreme cold, extreme heat, and vibration, risk of electrical shock.

The noise level in the work environment is usually moderate.

**COMMENTS:**

Employees appointed to positions in this class are required to be neatly groomed as needed to wear respiratory protection or other safety equipment.

# RANCHO MURIETA COMMUNITY SERVICES DISTRICT

## CHIEF PLANT OPERATOR

---

DEPARTMENT: WATER/WASTEWATER

FLSA OVERTIME STATUS: NON-EXEMPT

BARGAINING UNIT: N/A

APPROVED BY BOARD OF DIRECTORS – June 21, 2023

---

**SUMMARY:** Responsible for the daily supervision of staff to handle operations and maintenance of water and wastewater treatment plants, reservoirs, lift stations, dams, equipment and drainage facilities; to provide work scheduling and lead direction for other plant operator and maintenance staff; to oversee laboratory testing including such duties as sample collection and monitoring for compliance; monitors projects; provides technical assistance; responds to problems and emergencies; and to perform other job related work as required.

**SUPERVISION:** Receives general supervision from the Director of Field Operations. Provides direct supervision over Plant Operators and the Equipment Mechanic.

**ESSENTIAL DUTIES AND RESPONSIBILITIES** include the following. Other duties may be assigned.

- Supervises and oversees the operations and maintenance of water and wastewater treatment plants, reservoirs, lift stations, labs, lakes, dams, and drainage facilities;
- Provides work direction and scheduling for other staff; makes visual inspections of plant operations, insuring that operational problems have been located and corrected;
- Evaluates work methods, procedures, staff and equipment and recommends improvements, procedures, methods to improve efficiency and process capabilities;
- Plans, schedules and implements required routine, preventive, and emergency maintenance and repairs. Plans, schedules, and implements capital improvement projects;
- Responsible for in-house laboratory activities, maintains laboratory certification with Environmental License Accreditation Program, and coordinates and sends out a variety of samples for laboratory tests to comply with appropriate regulatory requirements and to ensure water quality;
- Maintains operations records and inspections and logs; updates information for

reports; analyzes records and reports to optimize efficiency and effectiveness;

- Assists with the preparation of annual budget and estimates of future district water needs; consults with engineering, health, environmental, suppliers, and others on changes in operations;
- Prepares and submits reports to Federal, State, County and local agencies;
- Requisitions and maintains an inventory of all equipment and supplies necessary to carry out system operations;
- Assists with employee evaluations and hiring process; assists in formulating and implementing safe work practices; provides on-the-job training for less experienced personnel;
- Identifies, develops and conducts safety and prevention training of staff in response to regulatory compliance and to maximize process, efficiency, operations, service and quality; and other related duties as assigned.

**DISTINGUISHING CHARACTERISTICS:**

This is the working supervisory level in the Plant Operator series. Incumbents are expected to perform the more difficult plant and facility operations and maintenance assignments with limited guidance and supervision; to provide work direction and scheduling for other staff; to have daily responsibility for operations and maintenance; conduct special studies and investigations related to water and wastewater treatment plant and distribution system construction, maintenance and operations.

**QUALIFICATION REQUIREMENTS:**

To perform this job successfully, an individual must be able to perform each essential duty satisfactorily. The requirements listed below are representative of the knowledge, skill, and/or ability required.

**Skills In:** computers, computer applications and software.

Ability to supervise personnel in a wide range of operations, repair, and maintenance work at water and wastewater treatment facilities. Develop, implement and maintain comprehensive asset management and preventative maintenance program. Maintain responsibility for operations and maintenance at assigned facilities. Read and interpret gauges and other recording devices reflecting water and wastewater treatment plant operations and make operating adjustments based upon recorded data. Monitor and manage the progress of multiple projects. Diagnose a variety of operating problems and take effective corrective actions. Communicate clearly and precisely verbally and written. Maintain logs, charts, records, reports, and budgets. Mentor and train less experienced staff. Establish and maintain cooperative working relationships. Respond to off hour emergencies and call outs.

**EDUCATION AND/OR EXPERIENCE:**

Any combination of training and experience which would provide the required knowledge and ability is qualifying. A typical way to obtain the requisite knowledge and ability would be:

Minimum Education: High School diploma and/or equivalent.

Two years of experience as a Plant Operator III with Rancho Murieta Community Services District; *or*

Three years of increasingly responsible work experience in the operation and maintenance of water and wastewater treatment and pumping facilities.

**CERTIFICATES, LICENSES, REGISTRATIONS:**

Possession of the category of California Driver's license required by the State Department of Motor Vehicles to perform the essential duties of the position. Continued maintenance of a valid driver's license, insurability, and compliance with established District vehicle operation standards are conditions of continuing employment.

Possession and maintenance of a Grade 3 Wastewater Plant Operator's Certificate of Competence issued by the California State Water Resources Control Board within 18 months of entering this position is required, and;

Possession and maintenance of a Grade 3 Water Treatment Operator's Certificate required by the California Department of Health Services within 18 months of entering this position is required, and;

Possession of a Grade 1 Laboratory Certificate issued by either the CWEA or the AWWA.

Possession of Grade 2 or higher Water Distribution Operator certificate is required within 18 months of hire.

Continued certification advancement is expected.

**PHYSICAL DEMANDS:**

The physical demands described here are representative of those that must be met by an employee to successfully perform the essential functions of this job.

While performing the duties of this job, the employee is frequently required to stand; walk; sit; climb or balance; and stoop, kneel, crouch, or crawl. The employee is occasionally required to use hands to finger, handle, or feel objects, tools, or controls; reach with hands and arms; and talk or hear.

The employee must occasionally lift and/or move up to 50 pounds. Specific vision abilities



required by this job include close vision, distance vision, color vision, peripheral vision, depth perception, and the ability to adjust focus.

**WORK ENVIRONMENT:**

The work environment characteristics described here are representative of those an employee encounters while performing the essential functions of this job. Reasonable accommodations may be made to enable individuals with disabilities to perform the essential functions.

While performing the duties of this job, the employee occasionally works near moving mechanical parts; in high, precarious places; and in outside weather conditions and is occasionally exposed to water and wastewater borne viruses and pathogens wet and/or humid conditions, fumes or airborne particles, toxic or caustic chemicals, extreme cold, extreme heat, and vibration, risk of electrical shock.

The noise level in the work environment is usually moderate.

**COMMENTS:**

Employees appointed to positions in this class are required to be neatly groomed as needed to wear respiratory protection or other safety equipment.



- Home
- How It Works
- Logout **Amelia Wilder**

### CSDA Board of Directors Election Ballot - Term 2024 - 2026; Seat C - Sierra Network

#### Please vote for your choice

Choose **one** of the following candidates:

- \*Pete Kampa, General Manager, Groveland Community Services District (incumbent)
- Kevin King, General Manager, Reclamation District 1000
- Beau Reynolds, North Highlands Recreation and Park District
- Nicholas Schneider, General Manager, Georgetown Public Utility District

\*Incumbent

**Pete Kampa\***    [\[hide details\]](#)

[Please click here for the candidate information sheet.](#)

[Please click here for the candidate statement.](#)

**Kevin King**    [\[hide details\]](#)

[Please click here for the candidate information sheet.](#)

[Please click here for the candidate statement.](#)

**Beau Reynolds**    [\[hide details\]](#)

[Please click here for the candidate information sheet.](#)



**Nicholas Schneider**    [\[hide details\]](#)

[Please click here for the candidate information sheet.](#)

Continue

Cancel

This is the online voting system of CSDA. Powered by [Simply Voting](#).



**2023 CSDA BOARD CANDIDATE INFORMATION SHEET**

The following information **MUST** accompany your nomination form and Resolution/minute order:

**Name:** Peter J. Kampa

**District/Company:** Groveland Community Services District

**Title:** General Manager

**Elected/Appointed/Staff:** Staff GM

**Length of Service with District:** 5 Years

**1. Do you have current involvement with CSDA (such as committees, events, workshops, conferences, Governance Academy, etc.):**

Member of the CSDA Board for 24 years and currently CSDA Vice President, serve on all CSDA committees, attend CSDA Annual Conference and GM

Leadership Summit annually, completed Governance Academy twice

**2. Have you ever been associated with any other state-wide associations (CSAC, ACWA, League, etc.):**

Eleven year member of ACWA and active on Legislative Committee and related task forces. Previous Board member with California Rural Water

Association and member for 15 years

**3. List local government involvement (such as LAFCo, Association of Governments, etc.):**

Spearheaded special district gaining seats on Tuolumne County LAFCo and attend all meetings, spearheaded formation of the Tuolumne County Chapter of CSDA and its current President, spearheaded formation of the Tuolumne-

Stanislaus Integrated Regional Water Management Authority

**4. List civic organization involvement:**

Hwy 120 Chamber of Commerce

**\*\*Candidate Statement** – Although it is not required, each candidate is requested to submit a candidate statement of no more than 300 words in length. **Any statements received in the CSDA office March 31, 2023, after 5:00 p.m. will not be included with the ballot.**

Peter J. Kampa, CSDM

CSDA Board Candidate Statement March 2023



*I seek your support for my reelection to the Board of Directors of California Special Districts Association. I have served 24 years as a member of the Board of Directors of the California Special Districts Association and am currently its Vice President as well as the Chair of its Member Services Committee. I am very active in CSDA functions and events attending all CSDA committee meetings, the CSDA conference, Legislative Days and GM Leadership Summit annually.*

*My goals as a CSDA Board member have been, and will continue to be, setting direction with the Board for the protection of local revenues, to bring realities to public works legislation and to convey the practicalities of running a special district to the legislature, regulators and other agencies. CSDA has seen amazing growth in membership and service delivery in the past two decades, and I intend to lead within the CSDA Board to continue to improve and keep relevant all of the offerings provided by CSDA.*

*I am a Certified Special District Manager who has served as General Manager for eleven special districts throughout Northern and Central California over my thirty-year career in local government, including a county water district, sanitary district and nine community services districts.*

*Public services delivered by the special districts under my management include water, sewer, ambulance, fire and emergency response, parks and recreation, solid waste, roads and stormwater, street lighting, snow removal, library, and mosquito protection. My management teams and I have administered the planning, design, funding and construction of over \$80 million in public facility construction, infrastructure and technology upgrades.*

*I currently serve as General Manager of the Groveland Community Services District in Tuolumne County and the Copper Valley CSD in Calaveras County.*



## 2023 CSDA BOARD CANDIDATE INFORMATION SHEET

The following information **MUST** accompany your nomination form and Resolution/minute order:

**Name:** Kevin L. King

**District/Company:** Reclamation District No. 1000

**Title:** General Manager

**Elected/Appointed/Staff:** Staff

**Length of Service with District:** 4 years

- 1. Do you have current involvement with CSDA (such as committees, events, workshops, conferences, Governance Academy, etc.):**

CSDA Legislative Committee 2020, General Manager Leadership Conference, CSDA Leadership Summit, CSDA District 6 Roundtables, CSDA Annual Conferences

- 2. Have you ever been associated with any other state-wide associations (CSAC, ACWA, League, etc.):**

ACWA

- 3. List local government involvement (such as LAFCo, Association of Governments, etc.):**

California Central Valley Flood Control Association - Board Member

- 4. List civic organization involvement:**

Natomas Chamber of Commerce

**\*\*Candidate Statement – Although it is not required, each candidate is requested to submit a candidate statement of no more than 300 words in length. Any statements received in the CSDA office after the nomination deadlines will not be included with the ballot.**





Reclamation District No. 1000  
1633 Garden Highway, Sacramento, CA 95833  
(916) 922-1449  
kking@rd1000.org  
[www.rd1000.org](http://www.rd1000.org)  
[www.4Natomas.org](http://www.4Natomas.org)

## Candidate Statement

### Kevin L. King



I am interested in serving on the California Special District's Board of Directors to more significantly contribute to the vitally important work done by CSDA. With more than two decades worth of experience in leadership roles for special districts, I certainly appreciate the significance of all special districts and believe my background and perspectives would be an asset as a member of the CSDA Board.

Upon graduating from California Polytechnic State University, San Luis Obispo, I began my career in public service at a small irrigation district in western Stanislaus County. My career has taken me on a path since that time with stops at Oakdale Irrigation District, Solano Irrigation District and currently as the General Manager of Reclamation District No. 1000 in Sacramento. The advocacy, resources, and support provided by CSDA each step of the way has been tremendous, not only to me personally but to the communities I served.

The challenges faced by special districts escalates, seemingly, on a daily basis. Funding challenges, legislative challenges, staffing challenges, modernization challenges...the list is endlessly, yet the need for our services never wanes. I am an enthusiastic, solution oriented and creative problem solver ready to take on these challenges. I believe my unique background; communication style and leadership would serve all special districts well.

I would be honored to receive your vote for the CSDA Board of Directors – Sierra Network

Warm regards,

Kevin L. King  
General Manager  
Reclamation District No. 1000



## 2023 CSDA BOARD CANDIDATE INFORMATION SHEET

The following information **MUST** accompany your nomination form and Resolution/minute order:

Name: BEAU Reynolds  
District/Company: North Highlands Recreation & Parks District  
Title: Director

Elected/Appointed/Staff: Elected

Length of Service with District: 2.5 years '20-'24 term

1. Do you have current involvement with CSDA (such as committees, events, workshops, conferences, Governance Academy, etc.):

2022 Leadership Academy Grad - NAPA

2. Have you ever been associated with any other state-wide associations (CSAC, ACWA, League, etc.):

No

3. List local government involvement (such as LAFCo, Association of Governments, etc.):

2023 Appointed - LAFCO - Special District Advisory

4. List civic organization involvement:

Stonewall Foundation of Greater Sacramento



## 2023 CSDA BOARD CANDIDATE INFORMATION SHEET

The following information **MUST** accompany your nomination form and Resolution/minute order:

**Name:** Nicholas Schneider

**District/Company:** Georgetown Divide Public Utility District

**Title:** General Manager

**Elected/Appointed/Staff:** Staff

**Length of Service with District:** 1 year

- 1. Do you have current involvement with CSDA (such as committees, events, workshops, conferences, Governance Academy, etc.):**

I currently serve on the Fiscal Committee and I have participated with the Legislative Committee for the last two years.

- 2. Have you ever been associated with any other state-wide associations (CSAC, ACWA, League, etc.):**

I am currently involved with ACWA, in that role I serve on the State Legislative Committee, Agriculture Committee, and many workgroups. Also involved with CMUA and served on their Leg Committee as well.

- 3. List local government involvement (such as LAFCo, Association of Governments, etc.):**

I have worked in local government for 10 plus years. I have presented to LAFCO many times and have also represented my District in front of a variety of local government associations.

- 4. List civic organization involvement:**

I serve as Boy Scout and Cub Scout leader. In the past I have coached little league.

**\*\*Candidate Statement – Although it is not required, each candidate is requested to submit a candidate statement of no more than 300 words in length. Any statements received in the CSDA office after the nomination deadlines will not be included with the ballot.**

## MEMORANDUM

Date: June 21, 2023  
To: Board of Directors  
From: Michael Fritschi, P.E. – Operations Director  
Subject: Main Lift North Comminutor Replacement

---

### Proposed Action

Approval of Resolution 2023-09 for an appropriation in the amount of \$30,918 (including 8.75% sales tax and a 15% contingency) from the Sewer Reserve to procure a replacement comminutor for Main Lift North.

### History

Main Lift North has (2) comminutors that shred rag material in the raw sewage influent to the Main Lift North Pump Station. Currently the second comminutor has broken down and continues to trip the breaker. The cutters from that comminutor are original and have become worn. The connecting drive shaft is bent, the bearings are suspected of partial failure, and the gearbox is also suspected as being a source of potential failure. Operators have been resetting the comminutor until the replacement comminutor can be procured. While in theory, the pump station can be operated with one working comminutor, replacing the second comminutor is of the utmost priority. As the failing comminutor continues to trip the breaker on almost a weekly basis, and to ensure adequate grinding redundancy, I have directed staff to order the comminutor replacement, as the lead time can range from 6-8 weeks

This procurement is considered a sole-source procurement as JWC Environmental is the only company that makes the comminutor in the dimensions and capacity required for this lift station installation. Staff were able to negotiate a reduction of \$2,778.43 (10%) off the original base price. Per Section 6.06 of the District procurement code allows for this if approved by the Board of Directors:

*“When the District requires Commodities or General Services that can be obtained or purchased from only one vendor, manufacturer, distributor authorized to sell within the District, or service provider, the General Manager may conduct negotiations with such vendor, manufacturer, distributor, or service provider to secure the most favorable terms and price without complying with the requirements of Sections 6.01 and 6.02 above. All single vendor/provider purchases shall be supported by written documentation indicating the facts and nature supporting the determination that the single vendor/provider purchase is appropriate in the circumstances. All single vendor/provider purchases in an amount or estimated amount exceeding \$25,000 require Board approval.”*

**att.** Quote from JWC  
Sole Source letter from JWC

**RESOLUTION R2023-09**

**A RESOLUTION AUTHORIZING THE DISTRICT TO ENTER INTO AN AGREEMENT WITH JWC ENVIRONMENTAL FOR REPLACEMENT OF THE MAIN LIFT NORTH COMMUNOTOR, APPROVE CIP#23-23-02, APPROPRIATE FUNDS IN THE AMOUNT OF \$30,918 AND AUTHORIZING THE GENERAL MANAGER TO EXECUTE THE AGREEMENT ON BEHALF OF THE DISTRICT**

**WHEREAS**, The District has identified the need to replace the comminutor at the main lift station north; and

**WHEREAS**, The District discovered that one of the two comminutors was failing, and staff continues to work to keep it running; and

**WHEREAS**, The District has located a replacement comminutor from JWC Environmental; and

**WHEREAS**, The District has verified that JWC Environmental is the only company that manufactures this piece of equipment therefore this will be a sole source purchase; and

**NOW, THEREFORE, THE RANCHO MURIETA COMMUNITY SERVICES DISTRICT DOES HEREBY RESOLVE AS FOLLOWS:**

1. Authorize the General Manager to enter into sole source procurement and to sign and execute the agreement, and amendments thereto, with JWC Environmental in the amount not to exceed \$30,918 (CIP# 23-23-02), attached as Exhibit 1.
2. Authorize a transfer of funds in the amount of \$30,918 from Wastewater reserves to include the cost of the proposal in the amount of \$26,885, plus a 15% contingency for a total project cost of \$30,918 and appropriate funds.
3. The General Manager is authorized to all necessary and appropriate actions to carry out the purpose and intent of this resolution.

**PASSED AND ADOPTED** this 21<sup>st</sup> day of June 2023 by the following roll call vote:

**Ayes:**

**Noes:**

**Absent:**

**Abstain:**

---

Timothy E. Maybee, President of the Board  
Rancho Murieta Community Services District

[SEAL]

Attest:

---

Amelia Wilder, District Secretary



Customer Service Center  
 2600 S. Garnsey Street  
 Santa Ana, CA 92707 USA  
 Phone: 949 833-3888  
 Toll Free: 800 331-2277  
 Fax: 714 242-0240

**Customer:** 5036606  
 Jason Dill  
 Rancho Murieta Community Services District  
 PO Box 1050  
 15160 Jackson Road  
 Rancho Murieta, CA 95683

US - UNITED STATES  
 916-870-5368

jdill@rmcsd.com

**Quote Number:** C-118324-G5S7-A  
**Quote Date:** 06/05/2023  
**Terms:** Net 30  
**Pricing:** Valid 60 Days  
**FOB:** Origin  
**Lead Time:** 8-10 Weeks ARO -Shipping & Handling Included  
**Grinder Serial #:** 870623  
**Ticket #:** C-118324-G5S7

**Project:** Rancho Murieta Community Services District

Part Number	Description	Qty	Unit Price	Extended Price
EVAL_CA	30002-0040 SN: 870623	1	\$0.00	\$0.00
30005-0040	30005-0040 Muffin Monster Upgrade  11 Tooth Cam Cutters 1:1 Stack Alloy Steel Buna N Elastomers Cork & Rubber Gaskets Motor Type Electric New 2HP TENV Motor (Wire @ 460V) New 29:1 Reducer New 3ft Extended Shaft New Spool Grinder SN: TBD ***** Paint: Epoxy Green *****	1	\$24,721.57	\$24,721.57
MANUALS	O&M MANUALS HARD COPY	2	\$0.00	\$0.00
Shipping	Shipping & Handling	1	\$0.00	\$0.00

*Please verify serial number is correct.*

**Sub Total** \$24,721.57  
**Tax**  
**Total** \$24,721.57

**Notes:**

1. Please fax or mail a Purchase Order for the total amount and we can process your order. Please include the following:  
 Bill to Address, Ship to Address, and sales tax exemption certificate.
2. Reference the JWC quote number on your purchase order..
3. Availability of parts are subject to change at any time.
4. 20% restocking fee on all returns.



**Rancho Murieta CSD**  
 15160 Jackson Road  
 P.O. Box 1050  
 Rancho Murieta, CA 95683  
 Phone: (916) 354-3700 Fax: (916) 354-2082

# PURCHASE ORDER

## No. C31076

**Date:** 06/14/2023  
**Terms:** Net 30  
**Send PO to Vendor:** Yes  
**Confirming Only:** No  
**Location:** 2345

JWC Environmental - 2850 S. Red Hill Ave  
 2850 S. Red Hill Ave Suite 125  
 Santa Ana, CA 92705

Ship  
 To:

Rancho Murieta CSD  
 15160 Jackson Road  
 Rancho Murieta CA 95683

**Important: Our Purchase Order Number Must Appear on Every Invoice and Package**

Qty	Description	Account	Unit Price	Amount
1	30005-0040 Muffin Monster Upgrade	Maintenance/Repairs - SC 250-5550-05	24,721.57	24,721.57

**Subtotal: \$ 24,721.57**

**Shipping: \$ 0.00**

**Tax Rate: 8.75% Tax: \$ 2,163.14**

**Submitted By:** Travis

**Total: \$ 26,884.71**

*Vendor subject to terms and conditions on both sides hereof.*

#### CONDITIONS AND TERMS OF PURCHASE

- Shipping tickets and/or packing slips must show in detail items shipped and must accompany all deliveries.
- Discount dates will be calculated from the date acceptable invoice or material purchased is received by us whichever is the later date. Invoices not showing terms will be understood to be net 30 days from date acceptable invoice is received, after receipt of materials or services.
- No charges will be accepted by the Purchaser for crating, boxing, cartage, drayage, storage or like services unless otherwise agreed.
- Invoices not received by the 25th day of the month of purchase may, at the option of Purchaser, be held until the following month and discounts taken.
- When prices, terms and deliveries are noted on the order, the Seller is not authorized to furnish or ship the items specified except on the basis of the prices, terms and deliveries needed, without written authorization from the Purchaser.
- The Purchaser reserves the right to refuse payment for any items billed at prices other than, or delivered at a date later than specified on this order without prejudice to the Purchaser's legal remedies for non-performance on the part of the Seller.



6/16/23, 12:53 PM

Purchase Order (No C31076)

7. All materials to conform to all applicable requirements of the plans, standard specifications and special provisions for the contract noted on the face of this order, such contract being incorporated and made a part of purchase order.
8. All necessary testing, inspection and approval of materials (or workmanship) by the proper authorities is to be provided and arranged by Seller at no additional cost to Purchaser.
9. The Seller agrees to furnish certificates of insurance if such are specifically required by the contract noted on the face of this order, without any cost to Purchaser.
10. If the Seller defaults regarding any provision of said purchase order, Purchaser has the right forthwith to declare this purchase order null and void.
11. The Seller agrees that if the Seller shall delay the material progress of the work so as to cause any damage for which the Purchaser shall become liable, the Seller shall become responsible for any such damage, loss, liability and other costs including attorney's fees.
12. Time is hereby declared as the essence of this contract.
13. Quantities shown in the purchase order are approximate and subject to revision at Purchaser's discretion without change in unit price.
14. Seller may not assign this contract or any portion thereof, or any monies or any portion thereof to become due or due under it, or subcontract hereunder without first obtaining the written consent of Purchaser. Purchaser may, by notice in writing, terminate this order without liability except for items already delivered. The provisions of this paragraph shall not limit or affect the right of the Purchaser to terminate this order for the default of the Seller.
15. This purchase order shall be subject to, and shall be conditioned upon, compliance with all applicable provisions of the Purchaser's Ordinance on purchases and bidding procedures (RMCSO Ordinance No. 83-2) and the California Public Contracts Code.
16. In the event action is instituted for the enforcement of any term or condition of this purchase order, the prevailing party shall be entitled to an award of reasonable attorney's fees in said suit in addition to costs and reasonable expenses incurred in the prosecution of, said suit.

Mimi Morris  
General Manager.

6/16/23.

For questions please call Travis