



RANCHO MURIETA COMMUNITY SERVICES DISTRICT

15160 JACKSON ROAD
RANCHO MURIETA, CA 95683
Phone: 916-354-3700
Web: rmcsd.com

Board of Directors

John Merchant, President
Linda Butler, Vice President
Bill Gere, Director
Randy Jenco, Director
Tim Maybee, Director

Staff

Amelia Wilder, Interim General Manager
Cecilia Min, Director of Finance and Administration
Travis Bohannon, Interim Director of Operations
Patrick Enright, District General Counsel
Branden Arino, Security Supervisor
Dyanne Fleet, Interim District Secretary/Clerk of the Board

**REGULAR MEETING
of the
BOARD OF DIRECTORS
Wednesday, June 17, 2026
Closed Session 4:00 p.m. Open Session 5:00 p.m.**

AGENDA

1. CALL TO ORDER - Determination of Quorum – President Merchant **(Roll Call)**

2. CLOSED SESSION

CONFERENCE WITH LEGAL COUNSEL — EXISTING/THREATENED LITIGATION

Pursuant to Government Code § 54956.9(d)(1)

Number of Cases: One (1)

Name of Case/Matter: River Canyon Properties, LLC v. Rancho Murieta Community Services District, et al.

3. OPEN SESSION/REPORT BACK FROM CLOSED SESSION

4. PUBLIC COMMENTS

The Public Comments section is for the Board of Directors to receive comments; except for brief questions for clarification, no discussion or action may be taken on any item that is not listed on the agenda.

If you wish to speak during Comments from the Public or would like to comment regarding an item appearing on the meeting agenda, you must complete a public comment card and submit it to the Board Secretary prior to Public Comments or the item you wish to comment on. Speakers presenting individual opinions shall have 3 minutes to speak. Speakers presenting opinions of groups or organizations shall have 5 minutes per group. Each individual will be limited to one (1) comment per item.

5. CONSENT CALENDAR *All items in this agenda item will be approved as one motion if they are not excluded from the motion adopting the consent calendar.*

A. Approval of Board Meeting and Committee Meeting Minutes

1. *May 27, 2026, Special Board Meeting Minutes*
2. *June 10, 2026, Improvements Committee Meeting Minutes*

- B. Bills Paid Listing
- C. Continue Emergency for Equestrian Center Culvert Repair
- D. Discontinue Emergency Work on 14th Hole N Culvert Repair
- E. Discontinue Emergency Mainline Repair at Yellow Bridge
- F. Approve Master Services Agreement with Veerkamp, Inc.
- G. Approve Annual Purchase for SCADA Software License from Rockwell Automation
- H. Approve Three Year Proposal from Aquatic Harvesting for Lake Chesbro \$15,000 (Price Locked in for 3 Years)
- I. Approve Purchase from Muniqip East DAF Recycle Pump \$9,780
- J. Approve Resolution R2026-06, A Resolution Calling the General District Election and Consolidation with the Statewide Election to be Held on November 3, 2026

6. REVIEW DISTRICT MEETING DATES/TIMES JULY 2026

- A. Improvements Committee – July 1, 2026, at 8:00 a.m.
- B. Security Committee – July 2, 2026, at 9:00 a.m.
- C. Communications & Technology Committee – July 2, 2026, at 10:00 a.m.
- D. Personnel Committee – July 7, 2026, at 9:00 a.m.
- E. Finance Committee – July 9, 2026, at 10:00 a.m.
- F. Regular Board Meeting – July 15, 2026, at 5:00 p.m.

7. CORRESPONDENCE

No Correspondence

8. STAFF AND COMMITTEE REPORTS (Receive and File)

- A. General Manager Report
- B. Operations Report

Action Items

9. *Action Item* APPROVE 2026 COSUMNES RIVER WATERSHED SANITARY SURVEY UPDATE \$37,990

10. *Action Item* APPROVE PROPOSED FY26-27 BUDGET INCLUDING CAPITAL IMPROVEMENT PROJECTS AND ADOPTION OF CORRESPONDING RESOLUTION R2026-13 APPROVING THE PROPOSED BUDGET FOR FY26-27

11. *Action Item* APPROVE ORDINANCE O2026-02 INCREASING WATER, SEWER AND SOLID WASTE SERVICE CHARGES AND STORM DRAINAGE AND SECURITY SPECIAL TAXES

12. DIRECTOR COMMENTS/SUGGESTIONS

13. ADJOURNMENT (Motion)

In accordance with California Government Code Section 54957.5, any writing or document that is a public record, relates to an open session agenda item and is distributed less than 24 hours prior to a special meeting, will be made available for public inspection in the District offices during normal business hours. If, however, the document is not distributed until the regular meeting to which it relates, then the document or writing will be made available to the public at the location of the meeting.

In compliance with federal and state laws concerning disabilities, if you are an individual with a disability and you need a disability-related modification or accommodation to participate in this meeting or need assistance to participate in this meeting, please contact the District Office at 916-354-3700 or dfleet@rmcsd.com. Requests must be made as soon as possible.

Note: This agenda is posted pursuant to the provisions of the Government Code commencing at Section 54950. Posting location is the District Office. The date and time of this posting is June 13, 2026, at 3:30 p.m.



RANCHO MURIETA COMMUNITY SERVICES DISTRICT REGULAR BOARD MEETING MINUTES

May 27, 2026

Closed Session 4:00 p.m./Open Session 5:00 p.m.

1. CALL TO ORDER/ROLL CALL

President Merchant called the Regular Board Meeting of the Board of Directors of Rancho Murieta Community Services District to order at 4:00 p.m. in the District meeting room, 15160 Jackson Road, Rancho Murieta. Directors present at the District office were Linda Butler, Bill Gere, Randy Jenco, Tim Maybee and John Merchant. Also present at the District office were Amelia Wilder, Interim General Manager; Cecilia Min, Director of Finance and Administration; Travis Bohannon, Interim Director of Operations and Chief Plant Operator; Patrick Enright, District General Counsel; and Dyanne Fleet, Interim District Secretary/Clerk of the Board.

2. APPROVE CERTIFICATE OF APPRECIATION HONORING JAMES COLAS

The Board presented James Colas with a Certificate of Appreciation recognizing his 20 years of dedicated service to the Rancho Murieta Community Services District. Mr. Colas was honored for his outstanding service, commitment, hard work, loyalty, and significant contributions to the District and its team.

3. APPROVE CERTIFICATE OF APPRECIATION HONORING JASON DILL

The Board presented Jason Dill with a Certificate of Appreciation recognizing his 20 years of dedicated service to the Rancho Murieta Community Services District. Mr. Dill was honored for his outstanding service, commitment, hard work, loyalty, and significant contributions to the District and its team.

4. CLOSED SESSION

- A. **CONFERENCE WITH LEGAL COUNSEL – EXISTING/THREATENED LITIGATION (Government Code section 54956.9(d)(1))**
Name of Case/Matter: River Canyon Properties LLC v. Rancho Murieta Community Services District et al. – (One Case)

5. OPEN SESSION

President Merchant reported that there was no action to report from the Closed Session.

6. PUBLIC COMMENTS

No. Public Comment

7. WSC Presentation Well Siting

WSC presented a screening-level test well siting study to identify potential exploratory drilling locations for evaluating groundwater availability and drought resiliency, emphasizing that the study was not a final production well design. The Board and public discussed candidate sites RM1–RM6, groundwater production potential, the corrected RM5 geology, possible distributed wells, well depths, infrastructure needs, impacts to nearby wells, aquifer recharge, floodplain permitting, and coordination with prior Dunn and Water Vision Working Group studies.

8. BROWN ACT TRAINING

District Counsel presented an overview of recent Brown Act updates under SB 707 and new fiscal training requirements under SB 827, covering meeting transparency, public participation, remote attendance

accommodations, teleconferencing rules, and mandatory financial training for elected officials and designated staff. The Board discussed current District practices, accessibility requirements, and the potential for livestreaming meetings.

9. CONSENT CALENDAR

Motion/Butler to Approve Consent Calendar Second/Gere. Roll Call Vote: Ayes: Butler, Gere, Jenco, Maybee, and Merchant. Noes: None. Absent: None: None. Abstain: None.

10. REVIEW DISTRICT MEETING DATES/TIMES JUNE 2025

The Board agreed to the District meeting dates and times for June.

11. CORRESPONDENCE

Email from N. Bloom – 5/12/2026

12. STAFF REPORTS

Complete Staff Reports can be found on April 15, 2026, Regular board Meeting Packet on the District's website or by clicking [here](#).

Under Agenda Item 12A, Ms. Wilder gave a summary of the General Manager update, including:

- Updates on Peckham & McKenney regarding the General Manager recruitment
- Updates on Development & Infrastructure
- Updates on HR Policies in Personnel Manual which will be brought back to the Board in July
- Update on Legislative Compliance (SB 707)
- Update on Emergency Sewer Main Repair & Financial Realty

Under Agenda Item 12A, Ms. Wilder updated the Board regarding IT Projects.

Under Agenda Item 12A, Mr. Arino updated the Board on Security regarding staffing, emergency after-hours contact information, and publishing monthly schedules.

Under Agenda Item 12B, Ms. Min gave a summary of the Finance & Administration update, including:

- Update on Audits
- Reviewed Budget Calendar
- Reviewed CIP Projects for FY26/27
- Reviewed Grant Opportunities for FY26/27

Under Agenda Item 12C, Mr. Bohannon gave a summary of the Operations Department update, including:

- Water Treatment Facility
- April 2026 Drinking Water Production Data
- Water Consumption
- Raw Water Storage & Delivery
- Utilities Activities
- Sewer
 - Wastewater Facility
- Project Updates
 - The Equestrian Culvert Repair
 - Hole 14 Culvert Repair

- Clementia Spillway Culvert Repair
- Emergency MLN Main Line Leak Repairs

Under Agenda Item 12D, Director Butler gave a summary on Personnel, Security, and Communications updates including:

- Reviewed Communications and Technology updates
- Reviewed Security updates
- Reviewed Personnel updates

13. AD HOC COMMITTEE REPORTS

a. ADMINISTRATIVE OVERSERITE/GM HIRING UPDATE

Directors Merchant and Gere updated the Board on items discussed at the Ad Hoc Committee.

b. WATER VISION REPORT

The Board discussed the future role and scope of the Water Vision Working Group, including concerns about transparency, public participation, and overlap with Board and committee responsibilities. Members reviewed the group's original objectives, ongoing work related to water supply planning and groundwater exploration, and the need to clearly define responsibilities for infrastructure, legal, and financial matters. The discussion concluded with direction to document the group's tasks and develop a framework for organizing future water-related projects and decision-making.

Motion/Maybee to have staff gather and present documentation regarding the WVWG, including formation, selection process, objectives, assigned tasks, completion status, and historical background.

Second/Butler. Roll Call Vote: Ayes: Butler, Gere, Jenco, Maybee, Merchant, and Maybee. Noes: None. Absent: None. Abstain: None.

Motion/Merchant to have the Improvements Committee identify and categorize water-related projects and responsibilities into fiscal, infrastructure, and legal tracks, develop a matrix outlining the above responsibilities, and bring the matrix back to the Board for discussion and action.

Second/Butler. Roll Call Vote: Ayes: Butler, Gere, Jenco, Maybee, Merchant, and Maybee. Noes: None. Absent: None. Abstain: None.

14. APPROVE EMERGENCY REPAIR SEWER MAIN LINE BREAK BY YELLOW BRIDGE

Staff reported that emergency repairs to the sewer mainline break near the Yellow Bridge had already been completed and that final project costs were approximately \$107,000, significantly below the originally authorized amount.

Motion/Merchant to Approve the Emergency Repair of the sewer main line break near the Yellow Bridge. Second Gere. Roll Call Vote: Ayes: Butler, Gere, Maybee, and Merchant. Nones: None, Absent: None. Abstain: Jenco.

15. PUBLIC HEARING TO RECEIVE AND CONSIDER WRITTEN PROTESTS RELATED TO WATER, WASTEWATER (SEWER) AND SOLID WASTE SERVICE RATE INCREASES PURSUANT TO CALIFORNIA CONSTITUTION, ARTICLE XIID, SECTION 6 (PROPOSITION 218) AND GOVERNMENT CODE SECTION 53755

President Merchant opened Proposition 218 public hearing regarding the proposed water, wastewater, and solid waste rate increases. Staff reported the number of service connections and written protests received. Public comments focused on the budget process, capital improvement planning, rate increases, long-term infrastructure replacement costs, and water system funding needs. After public comment, the hearing was closed and staff reported that no majority protest existed for any of the proposed rate increases.

President Merchant closed Proposition 218 Public Hearing and received the protest tally, finding that insufficient protests were submitted to constitute a majority protest for water, wastewater, or solid waste rates.

16. REVIEW FY26-27 OPEATING BUDGET, RESERVE DEVELOPMENT AND CIP

Ms. Min presented the proposed FY 2026–27 Budget and Capital Improvement Program, highlighting revisions that reduced projected expenses through staffing adjustments, reduced legal and maintenance costs, deferred software conversion expenses, and other budget refinements.

17. BOARD INTRODUCTION AND WAIVING OF FIRST READING OF ORDINANCE O2026-02 INCREASING WATER SEWER AND SOLID WASTE SERVICE CHARGES AND STORM DRAINAGE AND SECURITY SPECIAL TAXES.

Motion/Butler to Introduce and Waive the first reading of Ordinance O2025-02 increasing Water, Sewer and Solid Waste service charges and Storm Drainage and Security Special Taxes. Second/Gere. Roll Call Vote: Ayes: Butler, Jenco, Gere, Maybee, and Merchant. Noes: None. Absent: None. Abstain: None.

18. DIRECTOR COMMENTS/SUGGESTIONS

Director Maybee Thanked Staff for the removal of the Security Center and to remind staff to update the frontage sign.

19. ADJOURNMENT

Time meeting was adjourned at 9:09 p.m.

Respectfully submitted,

Dyanne Fleet
Interim District Secretary/Clerk of the Board

MEMORANDUM

Date: June 10, 2026
To: Board of Directors
From: Improvements Committee Staff
Subject: June 10, 2026, Improvements Committee Meeting Minutes

1. CALL TO ORDER

Director Gere called the meeting to order at 8:00 a.m. Present were Directors Gere and Jenco. Present from District staff were; Amelia Wilder, Interim General Manager, Travis Bohannon, Interim Director of Operations; Corey Carskaddon, Utility Supervisor; and Dyanne Fleet, Interim District Secretary/Clerk of the Board.

2. COMMENTS FROM THE PUBLIC

No Public Comments

3. IMPROVEMENTS STAFF REPORT

The following topics were discussed:

- A. Working Vision Group Update – Mr. Shewchuk presented the Water Vision Working Group update on its efforts to improve Rancho Murieta’s long-term water reliability, focusing on potential new well sites, Lake Clementia as a possible water source, water-use auditing, and future planning needs. The group reported progress reviewing historical and recent groundwater studies, recommended several well locations for potable and irrigation use, and emphasized the need for legal guidance, permitting review, grant funding opportunities, and further technical analysis before major decisions are made. Members also discussed ongoing questions about water demand projections, storage infrastructure, regulatory requirements, and the potential role of updated water management planning in supporting future community growth and drought resilience.
Ms. Wilder presented the Water Vision Working Group Matrix requested by the Board during the May 27, 2026, meeting. After discussions the Committee recommended condensing the Matrix into a shorter, more Board-friendly presentation. This item will be returned to the Improvements Committee in July.
- I. (Taken Out of Order) Multiple Storm Drainage Pipe Failure on North and South Golf Courses. – Mr. Bohannon and Mr. Carskaddon provided an informational update on repairs needed regarding the storm drainage pipe failure on North and South golf courses. The Committee agreed to repair all four drainage locations and combine repairs into a single project to reduce mobilization costs and improve efficiency. The Committee also indicated that once responsibility is confirmed and bids are obtained, the project could proceed directly to the Board for consideration.
- B. Update Emergency Mainline Repair at Yellow Bridge – Mr. Bohannon reported that repairs to the emergency mainline failure at the Yellow Bridge has been successfully completed. The Committee reviewed the status update and agreed to move this item with all invoices to the Board for formal closure.
- C. Update on MEC Culvert Repair Progress – Mr. Bohannon reported that the MEC Culvert Repair Project was awarded to M-3 Construction, Inc. and is scheduled to begin July 1st, with completion anticipated by July 31st. Progress is being made⁷ on securing the necessary right-of-entry

agreements, with one agreement already in hand and the second expected shortly. The agreements also ensure that the contractor's insurance appropriately names the affected property owner, the Equestrian Center, as an additional insured during the construction period.

- D. Update on 14th Hole N Culvert Repair – Mr. Bohannon reported that repairs to the 14th Hole North culvert have been completed. The Committee received the update, and no further discussion or action was requested regarding the project.
- E. Veerkamp Master Services Agreement –The Committee agreed to forward this item to the Board for consideration and approval.
- F. Annual Purchase for SCADA Software License from Rockwell Automation - Staff presented the annual renewal of the Rockwell Automation SCADA software license used to operate and monitor the District's water and wastewater treatment facilities. The Committee agreed to forward this item to the Board's Consent Calendar for approval.
- G. Three Year Proposal from Aquatic Harvesting for Lake Chesbro \$15,000 (Price Locked for 3 Years) – Mr. Bohannon presented a proposal from Aquatic Harvesting, who requested a three-year service commitment to assist with long-term scheduling and budgeting while maintaining the current annual rate. The Committee supported moving the proposed three-year commitment to the Board's Consent Calendar for approval.
- H. Purchase from Muniquip East DAF Recycle Pump \$9,780 – Mr. Bohannon requested authorization to purchase a replacement recycle pump for the east DAF at the wastewater treatment plant. Three of the facility's four recycle pumps have already been replaced, while the remaining pump is nearing the end of its service life and poses a risk of operational failure if not addressed proactively. The proposed purchase includes a complete pump and motor assembly that can be installed as a direct replacement. The Committee supported moving the purchase forward on the Consent Calendar for Board approval.
- J. Purchase 2026 Cosumnes River Watershed Sanitary Survey Update \$37,990 - Staff presented a proposal to update the District's required Watershed Sanitary Survey, which must be completed and submitted by December 31, 2026, in accordance with the State's five-year review requirement. The survey evaluates the District's entire water supply system and watershed, including the Cosumnes River, reservoirs, drainage areas, and potential sources of contamination that could affect drinking water quality. The Committee supported advancing this item to the Board for approval.
- K. Update Lisa Maddaus and Jim Farrell Discussion on IWMP Draft – Mr. Farrell provided an update on his ongoing discussions with water resources consultant Lisa Maddaus regarding the draft Integrated Water Management Plan (IWMP). He explained that the effort is focused on obtaining Lisa's professional engineering opinions on key assumptions, water demand projections, supply analysis, and other questions raised by the community and the Board. The anticipated outcome is a concise set of findings that clarifies water supply needs, planning assumptions, drought scenarios, and future demand projections, providing the Board with a consistent technical basis for long-term water planning decisions. The Committee directed staff and Mr. Farrell to continue working with Lisa Maddaus and provide another progress update at a future meeting.

4. DIRECTOR AND STAFF COMMENTS

No Comments

5. ADJOURNMENT

The meeting was adjourned at 9:45 a.m.

RANCHO MURIETA CSD - NEW
 VENDOR CHECK REGISTER REPORT
 Payables Management

Ranges: From: To: From: To:
 Check Number First Last Check Date 5/1/2026 5/31/2026
 Vendor ID First Last Checkbook ID BANNER BANNER
 Vendor Name First Last

Sorted By: Check Date

* Voided Checks

Check Number	Vendor ID	Vendor Check Name	Check Date	Checkbook ID	Audit Trail Code	Amount
003330	ACC&ASS	Accounting & Association Softw	5/13/2026	BANNER	PMCHK00001984	\$3,558.75
003331	ADVINT&CON	Advanced Integration & Control	5/13/2026	BANNER	PMCHK00001984	\$2,532.50
003332	APPBYDES	Applications By Design, LLC	5/13/2026	BANNER	PMCHK00001984	\$1,295.00
003333	CASTLAN	California State Lands Commiss	5/13/2026	BANNER	PMCHK00001984	\$694.28
003334	CALTRON	Caltronics	5/13/2026	BANNER	PMCHK00001984	\$142.12
003335	CINTAS	Cintas	5/13/2026	BANNER	PMCHK00001984	\$311.73
003336	CONEQUSER	Concrete Equipment Services, I	5/13/2026	BANNER	PMCHK00001984	\$1,282.53
003337	DITWITEQU	Ditch Witch Equipment Company,	5/13/2026	BANNER	PMCHK00001984	\$2,103.77
003338	ECSHOUNID	ECS House Industries, Inc.	5/13/2026	BANNER	PMCHK00001984	\$2,335.28
003340	FERWAT	Ferguson Waterworks	5/13/2026	BANNER	PMCHK00001984	\$5,549.88
003341	GRECOM	Greenfield Communications	5/13/2026	BANNER	PMCHK00001984	\$228.00
003342	HASCAPSAN	Hastie's Capitol Sand and Grav	5/13/2026	BANNER	PMCHK00001984	\$1,846.94
003343	HOLOFCAL	Holt of California	5/13/2026	BANNER	PMCHK00001984	\$1,200.54
003344	LUM&ASS	Lumos & Associates, Inc.	5/13/2026	BANNER	PMCHK00001984	\$262.91
003345	OCTWATQUA	OCT Water Quality Academy	5/13/2026	BANNER	PMCHK00001984	\$520.00
003346	OSNESCR	OSN Escrow Inc	5/13/2026	BANNER	PMCHK00001984	\$71.09
003347	OWEEQUSAL	Owen Equipment Co.	5/13/2026	BANNER	PMCHK00001984	\$22.02
003348	POL	Ferguson Enterprises LLC #3326	5/13/2026	BANNER	PMCHK00001984	\$2,066.10
003349	RAMENVSER	Ramos Oil Company	5/13/2026	BANNER	PMCHK00001984	\$2,609.19
003350	RANMURASS	Rancho Murieta Association	5/13/2026	BANNER	PMCHK00001984	\$382.75
003351	RIVCITREN	River City Rentals	5/13/2026	BANNER	PMCHK00001984	\$251.75
003352	SOLLAKMAN	Solitude Lake Management LLC	5/13/2026	BANNER	PMCHK00001984	\$6,580.45
003353	STAOFCALTAX	California Department of Tax a	5/13/2026	BANNER	PMCHK00001984	\$821.87
003354	CADEPWAT	Department of Water Resources	5/13/2026	BANNER	PMCHK00001984	\$77,640.00
003355	STATRASAF	AWP Safety	5/13/2026	BANNER	PMCHK00001984	\$95.60
003356	SYNSYS	Syneco Systems Inc	5/13/2026	BANNER	PMCHK00001984	\$4,801.75
003357	TESLA	TESLA INC	5/13/2026	BANNER	PMCHK00001984	\$20,409.06
003358	TNTINDCON	TNT Industrial Contractors Inc	5/13/2026	BANNER	PMCHK00001984	\$70,446.34
003359	UNIREN	United Rentals Northwest, Inc.	5/13/2026	BANNER	PMCHK00001984	\$5,141.46
003360	UNISOLUSA	Univar Solutions USA Inc	5/13/2026	BANNER	PMCHK00001984	\$9,818.42
003361	WML	W.M. Lyles Co.	5/13/2026	BANNER	PMCHK00001984	\$15,273.65
003362	WATSUR	Watchdogs Surveillance	5/13/2026	BANNER	PMCHK00001984	\$370.00
003363	COR&MAI	Core & Main LP	5/13/2026	BANNER	PMCHK00001985	\$1,151.79
EFT000000000122	A&DAUTGAT	A&D Automatic Gate	5/13/2026	BANNER	PMCHK00001986	\$4,857.88
EFT000000000123	ABSDIR	ABS Direct	5/13/2026	BANNER	PMCHK00001986	\$1,603.31
EFT000000000124	CALLABSER	California Laboratory Services	5/13/2026	BANNER	PMCHK00001986	\$2,567.00
EFT000000000125	CALWASREC	California Waste Recovery Syst	5/13/2026	BANNER	PMCHK00001986	\$127,928.06
EFT000000000126	PEC&MCK	City Management Advisors	5/13/2026	BANNER	PMCHK00001986	\$9,000.00
EFT000000000127	CLAPESCON	Clark Pest Control	5/13/2026	BANNER	PMCHK00001986	\$847.00
EFT000000000128	CON	Occupational Health Centers of	5/13/2026	BANNER	PMCHK00001986	\$777.00
EFT000000000129	EASTPEN	East Penn Manufacturing Co	5/13/2026	BANNER	PMCHK00001986	\$232.82
EFT000000000130	GOGREEN	Ewaste Recovery Systems	5/13/2026	BANNER	PMCHK00001986	\$4,755.96
EFT000000000131	INTTECSOL	Intelligent Technical Solution	5/13/2026	BANNER	PMCHK00001986	\$1,020.30
EFT000000000132	JUNKPAT	Junk Patrol LLC	5/13/2026	BANNER	PMCHK00001986	\$21,877.73
EFT000000000133	R&SOVEDOO	R&S Overhead Doors and Gates o	5/13/2026	BANNER	PMCHK00001986	\$2,356.20
EFT000000000134	RIC&COM	Richardson & Company, LLP	5/13/2026	BANNER	PMCHK00001986	\$900.00
EFT000000000135	ROTHSTF	Roth Staffing Companies, L.P.	5/13/2026	BANNER	PMCHK00001986	\$2,108.00
EFT000000000136	TAPMAST	Tap Master Inc	5/13/2026	BANNER	PMCHK00001986	\$2,198.00
EFT000000000137	USABLUBOO	HD Supply Inc DBA USABlueBook	5/13/2026	BANNER	PMCHK00001986	\$1,609.04
EFT000000000138	VESTIS	Vestis	5/13/2026	BANNER	PMCHK00001986	\$856.36
EFT000000000139	WWGRA	Grainger	5/13/2026	BANNER	PMCHK00001986	\$431.47
EFT000000000140	WALOFFSUP	Walker's Office Supplies, Inc	5/13/2026	BANNER	PMCHK00001986	\$78.15
EFT000000000141	DOMANDASS	Domenichelli & Associates, Inc	5/13/2026	BANNER	PMCHK00001986	\$11,574.00
EFT000000000157	AT&T	AT&T	5/15/2026	BANNER	PMPAY00000096	\$2,088.21
EFT000000000158	AT&T	AT&T	5/18/2026	BANNER	PMPAY00000097	\$9,281.99
003375	ADVINT&CON	Advanced Integration & Control	5/27/2026	BANNER	PMCHK00001987	\$1,162.50

* Voided Checks

Check Number	Vendor ID	Vendor Check Name	Check Date	Checkbook ID	Audit Trail Code	Amount
003376	AESSOF	Aestiva Software, Inc.	5/27/2026	BANNER	PMCHK00001987	\$5,658.00
003377	AQUMET	Aqua-Metric Sales Company	5/27/2026	BANNER	PMCHK00001987	\$3,886.05
003378	COITSER	Coit Services CV, Inc	5/27/2026	BANNER	PMCHK00001987	\$2,560.00
003379	COR&MAI	Core & Main LP	5/27/2026	BANNER	PMCHK00001987	\$3,468.22
003380	DITWITEQU	Ditch Witch Equipment Company,	5/27/2026	BANNER	PMCHK00001987	\$1,467.20
003381	FERENT	Ferguson Waterworks , Inc 1423	5/27/2026	BANNER	PMCHK00001987	\$11,465.41
003382	INDELE	Industrial Electrical Company	5/27/2026	BANNER	PMCHK00001987	\$8,397.06
003383	RAMENVSER	Ramos Oil Company	5/27/2026	BANNER	PMCHK00001987	\$3,497.89
003384	DEPFORF	CAL FIRE	5/27/2026	BANNER	PMCHK00001987	\$24,949.24
003385	UNIREN	United Rentals Northwest, Inc.	5/27/2026	BANNER	PMCHK00001987	\$2,189.73
003386	UNISOLUSA	Univar Solutions USA Inc	5/27/2026	BANNER	PMCHK00001987	\$12,554.50
003387	USABLUBOO	HD Supply Inc DBA USABlueBook	5/27/2026	BANNER	PMCHK00001987	\$3,512.19
EFT000000000145	ALLORA	Allora Cleaning LLC	5/27/2026	BANNER	PMCHK00001988	\$1,995.00
EFT000000000146	CHECHEUS	Chemtrade Chemicals US LLC	5/27/2026	BANNER	PMCHK00001988	\$3,768.19
EFT000000000147	DOMANDASS	Domenichelli & Associates, Inc	5/27/2026	BANNER	PMCHK00001988	\$51,019.00
EFT000000000148	EASTPEN	East Penn Manufacturing Co	5/27/2026	BANNER	PMCHK00001988	\$418.90
EFT000000000149	INTTECSOL	Intelligent Technical Solution	5/27/2026	BANNER	PMCHK00001988	\$8,517.24
EFT000000000150	ROBHAL	Robert Half	5/27/2026	BANNER	PMCHK00001988	\$28,011.47
EFT000000000151	ROTHSTF	Roth Staffing Companies, L.P.	5/27/2026	BANNER	PMCHK00001988	\$6,113.20
EFT000000000152	RWG	RWG Law	5/27/2026	BANNER	PMCHK00001988	\$38,114.91
EFT000000000153	TEIAGG	A. Teichert & Son Inc	5/27/2026	BANNER	PMCHK00001988	\$481.10
EFT000000000154	VESTIS	Vestis	5/27/2026	BANNER	PMCHK00001988	\$288.20
EFT000000000155	WALOFFSUP	Walker's Office Supplies, Inc	5/27/2026	BANNER	PMCHK00001988	\$70.43
Total Checks: 79						Total Amount of Checks: \$674,331.63



APS Environmental, Inc.
6643 32nd Street, Suite 101
North Highlands CA 95660
(916) 348-2800
Info@apsenvironmental.com

Invoice

DATE	05/26/2026
INVOICE #	40045158
TERMS	NET 60

BILL TO
Rancho Murieta CSD 15160 Jackson Rd. Rancho Murieta, Ca, 95683

SERVICE LOCATION
Rancho Murieta CSD Ponds 15160 Jackson Rd. Rancho Murieta, Ca, 95683

JOB#	JOB START DATE	PURCHASE ORDER	WORK DESCRIPTION
1013087075	05/17/2026	C35636	<p>PREVAILING WAGE - Emergency fee \$350 \$425.00 per truck, per hour, port to port Fuel Surcharge \$425.00 Broken 12"-15" sewer main.</p> <p>Completion Notes: Mark - Left the yard at 8:30am. Arrived on site at 10:00am. Left the site 1:30am. Arrived back to the yard at 2:30am. Pumped from a manhole and dumped at treatment plant to relieve pump station while it was turned off until the pipe repair could be done.</p> <p>Dan - Left the yard at 5:45pm. Arrived on site at 7:15am. Left the site at 12:30am. Arrived back to the yard at 1:45am. Pumped manhole, dumped on site.</p> <p>Bob - Left the yard at 8:00am. Arrived on site at 9:00am. Left the site at 1:30am. Arrived back to the yard at 2:30am. Pumped manhole, dumped on site.</p>

Description	Qty	Rate	Tax	Total
Othr-Emergency Fee Emergency Fee: after hours and/or weekend charge	1.00	\$350.00	\$0.00	\$350.00
Othr-Vac Truck Hourly Other - Vacuum Truck Per Hour (Port to Port)	18.00	\$425.00	\$0.00	\$7,650.00
Othr-Vac Truck Hourly Other - Vacuum Truck Per Hour (Port to Port)	8.00	\$425.00	\$0.00	\$3,400.00
Othr-Vac Truck Hourly Other - Vacuum Truck Per Hour (Port to Port)	18.50	\$425.00	\$0.00	\$7,862.50
O-Fuel Surcharge Fuel Surcharge	1.00	\$425.00	\$0.00	\$425.00

Invoice Total:	\$19,687.50
Payments (-):	\$0.00
Total Due:	\$19,687.50



Wastewater Hauler Load Manifest

CLIENT INFORMATION

Rancho Murieta CSD
 Paul Siebensohn
 15160 Jackson Rd.
 Rancho Murieta, Ca, 95683
 (916) 354-3700

 AP@rmcsd.com

Pumped Date:	05/26/2026	Manifest Number:	40045158
Site Address:	15160 Jackson Rd., Rancho Murieta, Ca, 95683	Waste Type:	Other
Truck License:		Disposal Site:	
CDFA Number:		Gallons Discharged:	

I hereby certify the information listed within this manifest is true and correct to the best of my knowledge. I further certify that the materials delivered at this time contain only those materials listed above and as certified to the customer certification directly above, and to the best of my knowledge, does not contain hazardous waste as defined by the E.P.A.

Field Technician: Dan

Certified Date: 05/26/2026

Coastline Water Resources, Inc
 PO Box 796
 Roseville, CA 95678
 916 923-3437

Work Order Invoice 9209

Date: 05/17/26

Bill to: RMCS D P.O. Box 1050 Rancho Murieta, CA 95683	Job Address: ER-CALL Sewer Overflow
---	--

Customer Code	Payment Terms	Customer PO Number	Quote	Type	Page
085	Net 30			T	1
Remarks: ER-CALL Sewer Overflow WO# 9209					

Description of Work Completed

DSR_RMCS 1 ER-CALL Sewer Overflow - 15160 Jackson Road _Saturday 05-17-26
 WO: 9209
 Crew: H-13 Espiridion Licea / ---
 Foreman: () -
 Superintendent: () -
 Scope of Work: ER- CALL Sewer Overflow (Sunday)
 Sewer Completed LF:
 Storm Completed LF:
 DI's Completed:
 Laterals Completed:
 Manholes Inspected:
 Notes/Job Delays: dewatered over 30 loads of live sewage from lift stations to waste water treatment plant.
 Potholing/Hydro-Excavation:
 Remaining:

Labor & Equipment Used

Week ending 05/23/26	Sun 5/17	Mon 5/18	Tues 5/19	Wed 5/20	Thur 5/21	Fri 5/22	Sat 5/23	Total Hours	Rate	Extension
LABOR USED	17.00							17.00	575.00	9,775.00

Invoice Totals:	Labor	Material	Other	9,775.00
	9,775.00	0.00	0.00	

Invoice Total: **9,775.00**

DATE OF REPORT: 5/27/26

FIELD INSTRUCTION NUMBER _____

PC NUMBER _____

WORK PERFORMED BY: 5/17/2026-5/18/2026

5/27/2026

CONTRACT NO : _____

DESCRIPTION OF WORK: TNT Industrial Contractors Inc

REPORT SUMMARY NUMBER _____

CONTRACTOR JOB NO 6782

Sewer main repair

CONTRACTOR REPORT NO 1

REPORT #	DESCRIPTION	TO DATE	AMOUNT	TOTAL AMOUNT TO DATE	\$	66,863.69
1	Sewer main repair		\$ 58,554.32			
2	Repair 2" line and connect to main, backfill and compact		\$ 7,289.51			
3	Demobilize and haul materials to landfill		\$ 1,019.86			



Contractor's License No. 622974

Phone (916) 395-8400 • FAX (916) 395-8429
3600 51st Avenue • Sacramento, CA 95823

05/17/26
Date: into the 18th

Work Order #: 6782-001

DAILY TIME AND MATERIAL REPORT

Project Name: Rancho Murieta Emergency Pipe Repair At Hwy 16 Customer Order #: Travis/Corey

Description of Work: Excavate /Pot Hole with Vac Trucks and add New 2 inch Saddle to 12 inch AC Pipe

LABOR, GRADE AND CLASS	EMPLOYEE NAME	# OF HOURS			RATE PER HOUR			TOTAL
		S.T.	1.5x	2x	S.T.	1.5x	2x	
Project Man.	Josh Twist			16				
Supt	Richard Stent			17				
Pipe Fit Form	Jesse Krpan			10				
Pipe Fit Form	Brandon Ferreira			12				
Lab Foreman	Mario Chavez			16				
Lab Foreman	Jared Bonds			17				
J-Carp	Raymond Gettler			17				
Appt Laborer	Jesse Murchinson			17				
TOTAL LABOR								

EQUIPMENT	HOURS	DAILY RATE	AMOUNT
TNT Truck #22,40,37,	17		
PM Truck	16		
Truck #55	10		
Flatbed Truck with sand bags No Number on Truck (Brandon Drove)	12		
TOTAL EQUIPMENT			

MATERIALS/SUBCONTRACTORS	P.O./INVOICE NO.	QUANTITY	UNIT PRICE	AMOUNT
Vacume Trucks	At repair site	3 ea		
Traffic Control with 3 ea Light Towers				
5 Gal Diesel to Vac Trailer Owner Supplied				
2 Rooms at Rancho Murieta Inn And Spa	Still awaiting Receipt Via E-Mail		Approx. \$171.00x 2	
TOTAL MATERIALS/SUBCONTRACTORS				

Submitted By: Richard Stent
Job Foreman

Approved By: Travis /Corey Carskddon
Customer

Date: 05-17,18 -2026

Date: 05-17,18 -2026



Finished Work Order Invoice

Nor-Cal Pipeline Services
 983 Reserve Drive
 Roseville, CA 95678

Invoice #: 8438

Invoice Date: 5/17/26

Terms: 2% 10 Net 30

Work Order 8556

Job: Emergency RMCSD MLN	Bill To: TNT Industrial Contractors Inc 3800 Happy Lane Sacramento, CA 95827
-----------------------------	---

JOB NUMBER: SA25603
 CONTACT:
 TECHNICIAN: Darryl L. Gaines
 Nathan Ryan

JOB SITE PHONE:
 JOB NUMBER: SA25603

CUSTOMER PO #: PO# 6782
 WORK DATE: 05/17/26

LABOR & MATERIALS USED:

Date	Time	Technician	Phase	CT	Hours	Rate	Extension
05/17/26	14:30	02:00	CHIES001	1000 - Labor	L		
05/17/26	09:00	19:30	GAIN001	1000 - Labor	L		
05/17/26	19:30	01:00	GAIN001	1000 - Labor	L		
05/17/26	09:00	19:30	RYAN001	1000 - Labor	L		
05/17/26	19:30	01:00	RYAN001	1000 - Labor	L		

TNT INDUSTRIAL
 CONTRACTORS, INC.

MAY 22 2026

RECEIVED

LABOR TOTAL: 0.00

Qty	UM	Item	Phase	CT	Price	Total
15.00	HR	COMBODT - Combo Clean DT	1020 - Equipment	E	420.00	6,300.00
15.00	HR	COMBODT - Combo Clean DT	1020 - Equipment	E	420.00	6,300.00
11.00	HR	COMBODT - Combo Clean DT	1020 - Equipment	E	420.00	4,620.00

MATERIALS TOTAL: 17,220.00

Item	Phase	CT	Total
FS10 - 10% Fuel Surcharge	1040 - Other Costs	O	1,722.00

OTHER TOTAL: 1,722.00

CUSTOMER SUB TOTAL: 18,942.00
 SALES TAX:
 INVOICE TOTAL: 18,942.00



Invoice

Right Traffic California LLC (Formerly WBE Traffic LLC)
 5150 Fair Oaks Blvd. , Ste.101-362
 Carmichael, CA 95608
 707-771-5870

Date	Invoice #
5/17/2026	RCA9506
Terms	
NET 30	

Bill To
TNT Industrial Contractors, Inc. 3800 Happy Lane Sacramento, CA 95827
Job Location
RANCHO MURIETA COUNTRY CLUB JACKSON RD RANCHO MURIETA, CA 95683 Sacramento County

Qty	Description	Work Order/Ticket	Rate	Amount
17.00	5/17/2026 TRAFFIC CONTROL- TYPICAL: SUN/HOL RATE - 2 FLAGGERS - HOURLY RATE	Emgerncy	375.00	6375.00
1.00	5/17/2026 MISSED MEAL PER 2 FLAGGERS	Emgerncy	125.00	125.00
Total				\$6,500.00

TNT INDUSTRIAL
 CONTRACTORS, INC.

MAY 20 2026

RECEIVED

Remittance address:
Right Traffic California LLC (Formerly WBE Traffic LLC)
ATT: Accounts Receivable
1200 Sharon Rd.
Suite 1
Beaver, PA 15009

Josh Twist

From: rick stent
Sent: Wednesday, May 20, 2026 7:28 AM
To: Josh Twist
Cc: Maria Arreigue
Subject: FW: The Murieta Inn and Spa – Reservation Folio

Internal (rstent@tntindustrial.com)

[Safe](#) [Spam](#) [Phish](#) [More...](#) [FAQ](#) [Protection by INKY](#)

T&M Rancho Cordova 6782-001

From: The Murieta Inn and Spa <admin@cloudbeds.com>
Sent: Wednesday, May 20, 2026 7:24 AM
To: rick stent <rstent@tntindustrial.com>
Subject: The Murieta Inn and Spa – Reservation Folio

The Murieta Inn and Spa

Thank you for choosing The Murieta Inn and Spa for your stay. For your convenience, your hotel folio is included below.

Josh Twist

From: rick stent
Sent: Wednesday, May 20, 2026 7:27 AM
To: Josh Twist
Cc: Maria Arreigue
Subject: FW: The Murieta Inn and Spa – Reservation Folio

Internal (rstent@tntindustrial.com)

[Safe](#) [Spam](#) [Phish](#) [More...](#) [FAQ](#) [Protection by INKY](#)

T&M Rancho Cordova 6782-001

From: The Murieta Inn and Spa <admin@cloudbeds.com>
Sent: Wednesday, May 20, 2026 7:22 AM
To: rick stent <rstent@tntindustrial.com>
Subject: The Murieta Inn and Spa – Reservation Folio

The Murieta Inn and Spa

Thank you for choosing The Murieta Inn and Spa for your stay. For your convenience, your hotel folio is included below.

Richard Joseph Stent

505XU7TS33

CHECKED OUT

The Murieta Inn and Spa
7337 Murieta Drive
Rancho Murieta California 95683
916.354.3900
FrontDesk@MurietaInn.com

Email rstent@tntindustrial.com
Phone 916-529-3874

Street Address 12209 Sunset Ave
City Grass Valley
Province / State California
Postal / ZIP Code 95945

RES ID	DATE/TIME	NAME	TYPE	QUANTITY	DEBIT	CREDIT
505XU7TS33	05/18/2026	Richard Joseph Stent	Room rate - Balcony Two Queen 225		\$190.00	\$0.00
505XU7TS33	05/18/2026	Richard Joseph Stent	Transient Occupancy Tax 225		\$22.80	\$0.00
505XU7TS33	05/18/2026	Richard Joseph Stent	Resort 225		\$12.00	\$0.00
505XU7TS33	05/18/2026	Richard Joseph Stent	CA Tourism 225		\$0.37	\$0.00

505XU7TS33 05/18/2026	Richard Joseph Stent	Credit Card 225	\$0.00	\$225.17
-----------------------	----------------------	-----------------	--------	----------

Total	USD 225.17	USD 225.17
-------	------------	------------

	TOTAL
Deposit	\$0.00
Subtotal	\$190.00
Additional Items	\$0.00
Transient Occupancy Tax	\$22.80
CA Tourism	\$0.37
Resort	\$12.00
Grand Total:	\$225.17
Amount Paid	\$225.17
Balance Due	\$0.00

If you have any questions or concerns regarding your folio, please contact us.

Jared Bonds

505JV941K3

CHECKED OUT

The Murieta Inn and Spa
7337 Murieta Drive
Rancho Murieta California 95683
916.354.3900
FrontDesk@MurietaInn.com

Email rstent@tntindustrial.com
Phone 916-395-8400

Street Address 1046 Bear Paw Rd
City Camdenton
Province / State Missouri
Postal / ZIP Code 65020

RES ID	DATE/TIME	NAME	TYPE	QUANTITY	DEBIT	CREDIT
505JV941K3	05/19/2026	Jared Bonds	Credit Card 217		\$0.00	\$248.17
505JV941K3	05/18/2026	Jared Bonds	Room rate - Balcony King 217		\$190.00	\$0.00
505JV941K3	05/18/2026	Jared Bonds	Transient Occupancy Tax 217		\$22.80	\$0.00
505JV941K3	05/18/2026	Jared Bonds	Resort 217		\$12.00	\$0.00
505JV941K3	05/18/2026	Jared Bonds	CA Tourism 217		\$0.37	\$0.00
505JV941K3	05/18/2026	Jared Bonds	Chow Mein 217	1	\$4.64	\$0.00
505JV941K3	05/18/2026	Jared Bonds	Sales Tax Inclusive		\$0.36	\$0.00

		For Marketplace 217			
505JV941K3 05/18/2026	Jared Bonds	Mission Cocktails 217	1	\$18.00	\$0.00
			Total	USD 248.17	USD 248.17

		TOTAL
	Deposit	\$0.00
	Subtotal	\$190.00
	Additional Items	\$22.64
	Sales Tax Inclusive For Marketplace	\$0.36
	Transient Occupancy Tax	\$22.80
	CA Tourism	\$0.37
	Resort	\$12.00
	Grand Total:	\$248.17
	Amount Paid	\$248.17
	Balance Due	\$0.00

If you have any questions or concerns regarding your folio, please contact us.

Date	05/17/2026	Work Order #	Emergency
Client	TNT Industrial Contractors, Inc.	Contract #	2572
			TNT Industrial Contractors, Inc
Foreman	TWIST, JOSH	Requested By	TWIST, JOSH
Job Location	RANCHO MURIETA COUNTRY CLUB JACKSON RD RANCHO MURIETA, CA 95683 (Sacramento County, LIUNA North)		
Meeting Location	RANCHO MURIETA COUNTRY CLUB JACKSON RD RANCHO MURIETA, CA 95683		

Name	Charge Type	Start Time	Start Break	End Break	End Time	Reg	OT	DT	Total
BENITEZ, ANDRES	Traffic Control	9:00AM	---	---	2:00AM	0.00	0.00	17.00	17.00
	Missed Meal Charge	12:00AM	---	---	12:30AM	0.00	0.00	0.50	0.50
	Missed Meal Charge	12:00AM	---	---	12:30AM	0.00	0.00	0.50	0.50
	Totals					0.00	0.00	18.00	18.00

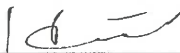
Name	Charge Type	Start Time	Start Break	End Break	End Time	Reg	OT	DT	Total
VALERO, HECTOR	Missed Meal Charge	12:00AM	---	---	12:30AM	0.00	0.00	0.50	0.50
	Traffic Control	9:00AM	---	---	2:00AM	0.00	0.00	17.00	17.00
	Missed Meal Charge	12:00AM	---	---	12:30AM	0.00	0.00	0.50	0.50
	Totals					0.00	0.00	18.00	18.00

Additional Charges

Name	Charge Type	Quantity
RCA-112	Work Truck - Daily	1.00

Notes

[Field Note] 1097@9:25am and 1098@1:15am light towers 1019 and 1030 left on site turned on around work site with customer.

Signatures

Date

CrewLead Signature

BENITEZ, ANDRES

05/18/2026





Phone (916) 395-8400 • FAX (916) 395-8429
3600 51st Avenue • Sacramento, CA 95823

Date: 05-18-2026

Work Order #: 6782-002

DAILY TIME AND MATERIAL REPORT

Project Name: Rancho Murieta Emergency Pipe Repair At Hwy 16 Customer Order #: Travis/Corey

Description of Work: Repair 2 inch PVC Pipe From Bathroom and allow to Dry and Test for leakage

all good 3.5 Hour Told owner to turn on Pumps Next day Backfill and bring to Finish Grade

Sand and ABSupplied by Owner ,As-Built Drawings

LABOR, GRADE AND CLASS	EMPLOYEE NAME	# OF HOURS			RATE PER HOUR			TOTAL
		S.T.	1.5x	2x	S.T.	1.5x	2x	
Supt	Richard Stent	8						
Lab Foreman	Mario Chavez	8	1					
Lab Foreman	Jared Bonds	8						
Appt Laborer	Robert Torres	8	1					
TOTAL LABOR								

EQUIPMENT	HOURS	DAILY RATE	AMOUNT
TNT TRUCK # 40	8		
TNT TRUCK # 37	9		
Dump Trailer DT2	9		
TOTAL EQUIPMENT			

MATERIALS/SUBCONTRACTORS	P.O./INVOICE NO.	QUANTITY	UNIT PRICE	AMOUNT
TOTAL MATERIALS/SUBCONTRACTORS				

Submitted By: Richard Stent
Job Foreman

Approved By: Travis /Corey Carskddon
Customer

Date: 05-18 -2026

Date: 05-18 -2026



Invoice

Right Traffic California LLC (Formerly WBE Traffic LLC)
 5150 Fair Oaks Blvd. , Ste.101-362
 Carmichael, CA 95608
 707-771-5870

Date	Invoice #
5/18/2026	RCA9704
Terms	
NET 30	

Bill To
TNT Industrial Contractors, Inc. 3800 Happy Lane Sacramento, CA 95827
Job Location
RANCHO MURIETA COUNTRY CLUB JACKSON RD Rancho Murieta, CA 95683 Sacramento County

Qty	Description	Work Order/Ticket	Rate	Amount
8.00	5/18/2026 TRAFFIC CONTROL - TYPICAL: 2 FLAGGERS - M-F HOURLY, 8 HR	2572-33	222.00	1776.00
0.50	5/18/2026 OVERTIME RATE PER 2 FLAGGERS	2572-33	325.00	162.50
Total				\$1,938.50

TNT INDUSTRIAL
 CONTRACTORS, INC.

MAY 26 2026

RECEIVED

Remittance address:
Right Traffic California LLC (Formerly WBE Traffic LLC)
ATT: Accounts Receivable
1200 Sharon Rd.
Suite 1
Beaver, PA 15009

Date	05/18/2026	Work Order #	2572-33
Client	TNT Industrial Contractors, Inc.	Contract #	2572
			TNT Industrial Contractors, Inc
Foreman	TWIST, JOSH	Requested By	TWIST, JOSH
Job Location	RANCHO MURIETA COUNTRY CLUB JACKSON RD Rancho Murieta, CA 95683 (Sacramento County, LIUNA North)		
Meeting Location	(ADJ) 10359 Macready Avenue Mather, CA 95655		

Name	Charge Type	Start Time	Start Break	End Break	End Time	Reg	OT	DT	Total
GOMEZ-GARCIA, ALEJANDRO	Traffic Control	9:00AM	---	---	5:30PM	8.00	0.50	0.00	8.50
	Totals					8.00	0.50	0.00	8.50

Name	Charge Type	Start Time	Start Break	End Break	End Time	Reg	OT	DT	Total
VALERO, HECTOR	Traffic Control	9:00AM	---	---	5:30PM	8.00	0.50	0.00	8.50
	Totals					8.00	0.50	0.00	8.50



Additional Charges

Name	Charge Type	Quantity
RCA-047	Work Truck - Daily	1.00

Notes

[Field Note] Brought back Lt 1030, Lt 1019 to yard .
Caltrans Id T16GA. 1097 was started at 9:00 am. Ended 1098 5:30 pm

Signatures

		<u>Date</u>
CrewLead Signature	VALERO, HECTOR	05/18/2026
		
Client Signature	TWIST, JOSH	05/18/2026
		

Network: May 19, 2026 at 2:43:13 PM PDT
Local: May 19, 2026 at 2:43:13 PM PDT

KIEFER LANDFILL FACILITY
HOURS: MON-FRI 6:30 AM-4:30 PM
SAT-SUN 8:30 AM-4:30 PM
INFORMATION: 916-875-5555

Weighed: 1043926
Deposit: 1047665

BILL TO: 21910
TNT INDUSTRIAL CONTRACTORS
3800 HAPPY LN
SACRAMENTO CA 95827

HAULER: CASH CUSTOMER
Vehicle ID:
Reference: #40
Grid: M-1L
REMARK: EP17413

Origin: SACRAMENTO, COUNTY OF
DATE IN: 05/19/2026 TIME IN: 09:54:00
DATE OUT: 05/19/2026 TIME OUT: 10:18:23

INBOUND TICKET Number: 02-26072384

SCALE 3 GROSS WT.	18900	LB
SCALE 2 TARE WT.	15720	LB
NET WEIGHT	3180	LB

Qty	Description	Amount
1.59	Normal Refuse	97.55

TICKET AMOUNT: 97.55

X _____

Emergency Main Line Break North of Yellow Bridge

May May 24th – 25th, 2026

Travis Bohannon	20 hours	\$2500
Corey Carskaddon	17.9 hours	\$1955
Andrew Harre	7.0 hours	\$561
Kevin Todd	18.25 hours	\$1255
Cory Xavier	11 hours	\$1050
James Colas	8 hours	\$472
Phil Davis	13.62 hours	\$645
Boby Stoffel	22.58 hours	\$1175
Oscar Ceja	8.12 hours	\$250

Total \$9,863

Rancho Murieta Community Services District
Services Agreement

This Agreement is entered into as of the date last signed and dated below by and between Rancho Murieta Community Services District, a local government agency ("District"), and

Doug Veerkamp General Engineering, Inc., a CA Corporation
[Insert type and jurisdiction of entity] ("Contractor"), who agree as follows:

1 Scope of Work

Contractor shall perform the work and render the services described in the attached Exhibit A (the "Work"). Contractor shall provide all labor, services, equipment, tools, material and supplies required or necessary to properly, competently and completely perform the Work. Contractor shall determine the method, details and means of doing the Work.

2 Payment

2.1 District shall pay to Contractor a fee based on [check one]:

Contractor's time and expenses necessarily and actually expended or incurred on the Work in accordance with Contractor's fee schedule on the attached Exhibit A.

The fee arrangement described on the attached Exhibit A.

There shall be no compensation for extra or additional work or services by Contractor unless approved in advance in writing by District. Contractor's fee includes all of Contractor's costs and expenses related to the Work.

2.2 At the end of each month, Contractor shall submit to District an invoice for the Work performed during the preceding month. The invoice shall include a brief description of the Work performed, the dates of Work, number of hours worked and by whom (if payment is based on time), payment due, and an itemization of any reimbursable expenditures. If the Work is satisfactorily completed and the invoice is accurately computed, District shall pay the invoice within 30 days of its receipt.

3 Term

3.1 This Agreement shall take effect on the above date and continue in effect until completion of the Work, unless sooner terminated as provided below. Time is of the essence in this Agreement. If Exhibit A includes a Work schedule or deadline, then Contractor must complete the Work in accordance with the specified schedule or deadline, which may be extended by District for good cause shown by Contractor. If Exhibit A does not include a Work schedule or deadline, then Contractor must perform the Work diligently and as expeditiously as possible, consistent with the professional skill and care appropriate for the orderly progress of the Work.

3.2 This Agreement may be terminated at any time by District upon 10 days advance written notice to Contractor. In the event of such termination, Contractor shall be

fairly compensated for all work performed to the date of termination as calculated by District based on the above fee and payment provisions. Compensation under this section shall not include any termination-related expenses, cancellation or demobilization charges, or lost profit associated with the expected completion of the Work or other such similar payments relating to Contractor's claimed benefit of the bargain.

4 Professional Ability of Contractor

4.1 Contractor represents that it is specially trained and experienced, and possesses the skill, ability, knowledge and certification, to competently perform the Work provided by this Agreement. District has relied upon Contractor's training, experience, skill, ability, knowledge and certification as a material inducement to enter into this Agreement. All Work performed by Contractor shall be in accordance with applicable legal requirements and meet the standard of care and quality ordinarily to be expected of competent professionals in Contractor's field.

[The paragraphs in section 4.2 can be replaced with "Intentionally omitted" if the District is not requiring the Contractor to designate key personnel.]

4.2 *Intentionally omitted.*

5 Conflict of Interest

5.1 Contractor (including principals, associates and professional employees) represents and acknowledges that (a) it does not now have and shall not acquire any direct or indirect investment, interest in real property or source of income that would be affected in any manner or degree by the performance of Contractor's services under this agreement, and (b) no person having any such interest shall perform any portion of the Work. The parties agree that Contractor is not a designated employee within the meaning of the Political Reform Act and District's conflict of interest code because Contractor will perform the Work independent of the control and direction of the District or of any District official, other than normal contract monitoring, and Contractor possesses no authority with respect to any District decision beyond the rendition of information, advice, recommendation or counsel.

5.2 Contractor's duties and services under this Agreement shall not include preparing or assisting District with any portion of District's preparation of a request for proposals, request for qualifications, or any other solicitation regarding a subsequent or additional contract with District. District shall at all times retain responsibility for public contracting, including with respect to any subsequent phase of the work contemplated herein. Contractor's participation in the planning, discussions, or drawing of project plans or specifications shall be limited to conceptual, preliminary, or initial plans or specifications. Contractor shall cooperate with District to ensure that all bidders for a subsequent contract on any subsequent phase, if any, of work contemplated herein have access to the same information, including all conceptual, preliminary, or initial plans or specifications, if any, prepared by Contractor pursuant to this Agreement.

6 Contractor Records

6.1 Contractor shall keep and maintain all ledgers, books of account, invoices, vouchers, canceled checks, and other records and documents evidencing or relating to the

Work and invoice preparation and support for a minimum period of three years (or for any longer period required by law) from the date of final payment to Contractor under this Agreement. District may inspect and audit such books and records, including source documents, to verify all charges, payments and reimbursable costs under this Agreement.

6.2 In accordance with California Government Code section 8546.7, the parties acknowledge that this Agreement, and performance and payments under it, are subject to examination and audit by the California State Auditor for three years following final payment under the Agreement.

7 Ownership of Documents

All works of authorship and every report, study, spreadsheet, worksheet, plan, design, blueprint, specification, drawing, map, photograph, computer model, computer disk, magnetic tape, CAD data file, computer software and any other document or thing prepared, developed or created by Contractor under this Agreement and provided to District ("Work Product") shall be the property of District, and District shall have the rights to use, modify, reuse, reproduce, publish, display, broadcast and distribute the Work Product and to prepare derivative and additional documents or works based on the Work Product without further compensation to Contractor or any other party. Contractor may retain a copy of any Work Product and use, reproduce, publish, display, broadcast and distribute any Work Product and prepare derivative and additional documents or works based on any Work Product; provided, however, that Contractor shall not provide any Work Product to any third party without District's prior written approval, unless compelled to do so by legal process. If any Work Product is copyrightable, Contractor may copyright the same, except that, as to any Work Product that is copyrighted by Contractor, District reserves a royalty-free, nonexclusive and irrevocable license to use, reuse, reproduce, publish, display, broadcast and distribute the Work Product and to prepare derivative and additional documents or works based on the Work Product. If District reuses or modifies any Work Product for a use or purpose other than that intended by the scope of work under this Agreement, then District shall hold Contractor harmless against all claims, damages, losses and expenses arising from such reuse or modification. For any Work Product provided to District in paper format, upon request by District at any time (including, but not limited to, at expiration or termination of this Agreement), Contractor agrees to provide the Work Product to District in a readable, transferable and usable electronic format generally acknowledged as being an industry-standard format for information exchange between computers (e.g., Word file, Excel spreadsheet file, AutoCAD file).

8 Confidentiality of Information

[The paragraphs in this section can be replaced with the phrase "Intentionally omitted" if the District will not provide any confidential information to the Contractor.]

8.1 Contractor shall keep in strict confidence all confidential, privileged, trade secret, and proprietary information, data and other materials in any format generated, used or obtained by the District or created by Contractor in connection with the performance of the Work under this Agreement (the "Confidential Material"). Contractor shall not use any Confidential Material for any purpose other than the performance of the Work under this Agreement, unless otherwise authorized in writing by District. Contractor also shall not disclose any Confidential Material to any person or entity not connected with the

performance of the Work under this Agreement, unless otherwise authorized in advance in writing by District. If there is a question if Confidential Material is protected from disclosure or is a public record or in the public domain, the party considering disclosure of such materials shall consult with the other party concerning the proposed disclosure.

8.2 Contractor, and its officers, employees, agents, and subcontractors, shall at all times take all steps that are necessary to protect and preserve all Confidential Material. At no time shall Contractor, or its officers, employees, agents, or subcontractors in any manner, either directly or indirectly, use for personal benefit or divulge, disclose, or communicate in any manner, any Confidential Material to any person or entity unless specifically authorized in writing by the District or by order of a court or regulatory entity with jurisdiction over the matter. Contractor, and its officers, employees, agents, and subcontractors shall protect the Confidential Material and treat it as strictly confidential in accordance with applicable law, District policies and directives, and best industry security practices and standards.

8.3 If any person or entity, other than District or Contractor, requests or demands, by subpoena, discovery request, California Public Records Act request or otherwise, Confidential Material or its contents, the party to whom the request is made will immediately notify the other party, so that the parties may collectively consider appropriate steps to protect the disclosure of those materials. The parties agree to take all steps reasonably necessary to preserve the confidential and privileged nature of the Confidential Material and its content. In the event that the parties cannot agree whether to oppose or comply with a disclosure demand, the opposing party may oppose the demand at its sole cost and expense, in which event the party favoring disclosure will refrain from disclosing the demanded Confidential Material until such time as a final agreement regarding disclosure is reached or, if an agreement is not reached, a judicial determination is made concerning the demand.

8.4 Unless otherwise directed in writing by the District, upon contract completion or termination, Contractor must destroy all Confidential Materials (written, printed and/or electronic) and shall provide a written statement to the District that such materials have been destroyed.

9 Compliance with Laws

9.1 General. Contractor shall perform the Work in compliance with all applicable federal, state and local laws and regulations. Contractor shall possess, maintain and comply with all federal, state and local permits, licenses and certificates that may be required for it to perform the Work. Contractor shall comply with all federal, state and local air pollution control laws and regulations applicable to the Contractor and its Work (as required by California Code of Regulations title 13, section 2022.1). Contractor shall be responsible for the safety of its workers and Contractor shall comply with applicable federal and state worker safety-related laws and regulations.

9.2 California Labor Code Compliance for Pre- and Post-Construction Related Work and Maintenance.

9.2.1 This section 9.2 applies if the Work includes either of the following:

9.2.1.1 Labor performed during the design, site assessment, feasibility study and pre-construction phases of construction, including, but not limited to, inspection

and land surveying work, and labor performed during the post-construction phases of construction, including, but not limited to, cleanup work at the jobsite. (See California Labor Code section 1720(a).) If the Work includes some labor as described in the preceding sentence and other labor that is not, then this section 9.2 applies only to workers performing the pre-construction and post-construction work.

9.2.1.2 "Maintenance" work, which means (i) routine, recurring and usual work for the preservation, protection and keeping of any District facility, plant, building, structure, utility system or other property ("District Facility") in a safe and continually usable condition, (ii) carpentry, electrical, plumbing, glazing, touchup painting, and other craft work designed to preserve any District Facility in a safe, efficient and continuously usable condition, including repairs, cleaning and other operations on District machinery and equipment, and (iii) landscape maintenance. "Maintenance" excludes (i) janitorial or custodial services of a routine, recurring or usual nature, and (ii) security, guard or other protection-related services. (See California Labor Code section 1771 and 8 California Code of Regulations section 16000.) If the Work includes some "maintenance" work and other work that is not "maintenance," then this section 9.2 applies only to workers performing the "maintenance" work.

9.2.2 Contractor shall comply with the California Labor Code provisions concerning payment of prevailing wage rates, penalties, employment of apprentices, hours of work and overtime, keeping and retention of payroll records, and other requirements applicable to public works as may be required by the Labor Code and applicable state regulations. (See California Labor Code division 2, part 7, chapter 1 (sections 1720-1861), which is incorporated in this Agreement by this reference.) The state-approved prevailing rates of per diem wages are available at <http://www.dir.ca.gov/opri/DPreWageDetermination.htm>. Contractor also shall comply with Labor Code sections 1775 and 1813, including provisions that require Contractor to (a) forfeit as a penalty to District up to \$200 for each calendar day or portion thereof for each worker (whether employed by Contractor or any subcontractor) paid less than the applicable prevailing wage rates for any labor done under this Agreement in violation of the Labor Code, (b) pay to each worker the difference between the prevailing wage rate and the amount paid to each worker for each calendar day or portion thereof for which the worker was paid less than the prevailing wage, and (c) forfeit as a penalty to District the sum of \$25 for each worker (whether employed by Contractor or any subcontractor) for each calendar day during which the worker is required or permitted to work more than 8 hours in any one day and 40 hours in any one calendar week in violation of Labor Code sections 1810 through 1815.

9.2.3 If the Work includes labor during pre- or post-construction phases as defined in section 9.2.1.1 above and the amount of the fee payable to Contractor under section 2 of this Agreement exceeds \$25,000, Contractor must be registered and qualified to perform public work with the Department of Industrial Relations pursuant section 1725.5 of the Labor Code.

Contractor's Public Works Contractor Registration Number: 1000004944

9.2.4 If the Work includes maintenance as defined in section 9.2.1.2 above and the amount of the fee payable to Contractor under section 2 of this Agreement exceeds \$15,000, Contractor must be registered and qualified to perform public work with the Department of Industrial Relations pursuant section 1725.5 of the Labor Code.

Contractor's Public Works Contractor Registration Number: 1000004944

d. [This paragraph may be replaced with "Intentionally omitted" if the Work is not subject to a grant or loan agreement] Contractor may perform some of the Work pursuant to funding provided to the District by various federal and/or state grant and/or loan agreement(s) that impose certain funding conditions on District and its sub-recipients (the "Funding Conditions"). For any such Work, if District informs Contractor about the Funding Conditions, then Contractor agrees to determine, comply with and be subject to the Funding Conditions that apply to District's Contractors and contractors performing the Work, including, but not limited to, provisions concerning record keeping, retention and inspection, audits, state or federal government's right to inspect Contractor's work, nondiscrimination, workers' compensation insurance, drug-free workplace certification, and, compliance with the Americans with Disabilities Act and related State laws.

10 Indemnification.

10.1 Contractor shall indemnify, defend, protect, and hold harmless District, and its officers, employees and agents ("Indemnitees") from and against any claims, liability, losses, damages and expenses (including attorney, expert witness and Contractor fees, and litigation costs) (collectively a "Claim") that arise out of, pertain to, or relate to the negligence, recklessness, or willful misconduct of Contractor or its employees, agents or subcontractors. The duty to indemnify, including the duty and the cost to defend, is limited as provided in this section. However, this indemnity provision will not apply to any Claim arising from the sole negligence or willful misconduct of District or its employees or agents. Contractor's obligations under this indemnification provision shall survive the termination of, or completion of Work under, this Agreement.

10.2 This section 10.2 applies if the Contractor is a "design professional" as that term is defined in Civil Code section 2782.8. If a court or arbitrator determines that the incident or occurrence that gave rise to the Claim was partially caused by the fault of an Indemnitee, then in no event shall Contractor's total costs incurred pursuant to its duty to defend Indemnitees exceed Contractor's proportionate percentage of fault as determined by a final judgment of a court or final decision of arbitrator.

11 Insurance

Types & Limits. Contractor at its sole cost and expense shall procure and maintain for the duration of this Agreement the following types and limits of insurance: [The general liability and automobile coverage limits may be adjusted depending on the Work's overall risks, cost and complexity.]

Type	Limits	Scope
Commercial general liability	\$2,000,000 per occurrence & \$4,000,000 aggregate	at least as broad as Insurance Services Office (ISO) Commercial General Liability Coverage (Occurrence Form CG 00 01) including products and completed operations, property damage, bodily

		injury, personal and advertising injury
Automobile liability	\$1,000,000 per accident	at least as broad as ISO Business Auto Coverage (Form CA 00 01)
Workers' compensation	Statutory limits	
Employers' liability	\$1,000,000 per accident	
Professional liability*	\$1,000,000 per claim	

*Required only if Contractor is a licensed engineer, land surveyor, geologist, architect, doctor, attorney or accountant.

11.1 Entitlement to Broader Coverage. If Contractor maintains broader coverage and/or higher limits than the minimums shown above, the District requires and shall be entitled to the broader coverage and/or higher limits maintained by Contractor. Any available insurance proceeds in excess of the specified minimum of insurance and coverage shall be available to the District. Furthermore, the above minimum insurance coverage limits can be met through provision of umbrella or excess policy insurance coverage consistent with the provisions of this section 11.

11.2 Other Requirements. The general and automobile liability policy(ies) shall be endorsed to name District, its officers, employees, volunteers and agents as additional insureds regarding liability arising out of the Work. Contractor's general and automobile coverage shall be primary and apply separately to each insurer against whom claim is made or suit is brought, except with respect to the limits of the insurer's liability. District's insurance or self-insurance, if any, shall be excess and shall not contribute with Contractor's insurance. Each insurance policy shall be endorsed to state that coverage shall not be canceled, except after 30 days (10 days for non-payment of premium) prior written notice to District. Insurance is to be placed with insurers authorized to do business in California with a current A.M. Best's rating of A:VII or better unless otherwise acceptable to District. Workers' compensation insurance issued by the State Compensation Insurance Fund is acceptable. Except for professional liability insurance, Contractor agrees to waive subrogation that any insurer may acquire from Contractor by virtue of the payment of any loss relating to the Work. Contractor agrees to obtain any endorsement that may be necessary to implement this subrogation waiver. The workers' compensation policy must be endorsed to contain a subrogation waiver in favor of District for the Work performed by Contractor.

11.3 Proof of Insurance. Upon request, Contractor shall provide to District the following proof of insurance: (a) certificate(s) of insurance evidencing this insurance; and (b) endorsement(s) on ISO Form CG 2010 (or insurer's equivalent), signed by a person authorized to bind coverage on behalf of the insurer(s), and certifying the additional insured coverage.

12 General Provisions

12.1 Entire Agreement; Amendment. The parties intend this writing to be the sole, final, complete, exclusive and integrated expression and statement of the terms of their contract concerning the Work. This Agreement supersedes all prior oral or written negotiations, representations, contracts or other documents that may be related to the Work,

except those other documents (if any) that are expressly referenced in this Agreement. This Agreement may be amended only by a subsequent written contract approved and signed by both parties.

12.2 Independent Contractor. Contractor's relationship to District is that of an independent contractor. All persons hired by Contractor and performing the Work shall be Contractor's employees or agents. Contractor and its officers, employees and agents are not District employees, and they are not entitled to District employment salary, wages or benefits. Contractor shall pay, and District shall not be responsible in any way for, the salary, wages, workers' compensation, unemployment insurance, disability insurance, tax withholding, and benefits to and on behalf of Contractor's employees. Contractor shall, to the fullest extent permitted by law, indemnify District, and its officers, employees, volunteers and agents from and against any and all liability, penalties, expenses and costs resulting from any adverse determination by the federal Internal Revenue Service, California Franchise Tax Board, other federal or state agency, or court concerning Contractor's independent contractor status or employment-related liability.

12.3 Subcontractors. No subcontract shall be awarded nor any subcontractor engaged by Contractor without District's prior written approval. Contractor shall be responsible for requiring and confirming that each approved subcontractor meets the minimum insurance requirements specified in section 11 of this Agreement. Any approved subcontractor shall obtain the required insurance coverages and provide proof of same to District in the manner provided in section 11 of this Agreement.

12.4 Assignment. This Agreement and all rights and obligations under it are personal to the parties. The Agreement may not be transferred, assigned, delegated or subcontracted in whole or in part, whether by assignment, subcontract, merger, operation of law or otherwise, by either party without the prior written consent of the other party. Any transfer, assignment, delegation, or subcontract in violation of this provision is null and void and grounds for the other party to terminate the Agreement.

12.5 No Waiver of Rights. Any waiver at any time by either party of its rights as to a breach or default of this Agreement shall not be deemed to be a waiver as to any other breach or default. No payment by District to Contractor shall be considered or construed to be an approval or acceptance of any Work or a waiver of any breach or default.

12.6 Severability. If any part of this Agreement is held to be void, invalid, illegal or unenforceable, then the remaining parts will continue in full force and effect and be fully binding, provided that each party still receives the benefits of this Agreement.

12.7 Governing Law and Venue. This Agreement will be governed by and construed in accordance with the laws of the State of California. The county and federal district court where District's office is located shall be venue for any state and federal court litigation concerning the enforcement or construction of this Agreement.

12.8 Notice. Any notice, demand, invoice or other communication required or permitted to be given under this Agreement must be in writing and delivered either (a) in person, (b) by prepaid, first class U.S. mail, (c) by a nationally-recognized commercial overnight courier service that guarantees next day delivery and provides a receipt, or (d) by email with confirmed receipt. Such notices, etc. shall be addressed as follows:

District:

Rancho Murieta Community Services District

Attn: _____

Rancho Murieta Community Services District, 15160 Jackson Road, Rancho Murieta,
CA 95683

E-mail: _____

Contractor:

Doug Veerkamp General Engineering, Inc.

Attn: Eric Wunschel

3701 Trade Way, Cameron Park, CA 95682

E-mail: eric.wunschel@dougveerkamp.com

Notice given as above will be deemed given (a) when delivered in person, (b) three days after deposited in prepaid, first class U.S. mail, (c) on the date of delivery as shown on the overnight courier service receipt, or (d) upon the sender's receipt of an email from the other party confirming the delivery of the notice, etc. Any party may change its contact information by notifying the other party of the change in the manner provided above.

12.9 Signatures and Authority. Each party warrants that the person signing this Agreement is authorized to act on behalf of the party for whom that person signs. This Agreement may be executed in two or more counterparts, each of which shall be deemed an original, but all of which together shall constitute the same instrument. Counterparts may be delivered by facsimile, electronic mail (including PDF or any electronic signature complying with California's Uniform Electronic Transactions Act (Cal. Civ. Code, §1633.1, et seq.) or any other applicable law) or other transmission method. The parties agree that any electronic signatures appearing on the Agreement are the same as handwritten signatures for the purposes of validity, enforceability, and admissibility.

Rancho Murieta Community Services District:

Dated: _____

By: _____

[Name]

[Title]

Doug Veerkamp General Engineering, Inc:

Dated: 5/14/2026

By: _____

Eric Wunschel, C.O.O.

PREVAILING WAGE LABOR + PRIVATE EQUIPMENT RATES EXPIRE 6/30/26			
**LABOR **	Straight Time PREVAILING	Overtime PREVAILING	Double Time PREVAILING
Project Manager	\$200.00		
Superintendent	\$175.00	\$205.00	\$255.00
Foreman [Group 2]	\$149.00	\$198.00	\$246.00
Operator [Group 4]	\$145.00	\$191.00	\$238.00
Grade Setter [Group 4]	\$145.00	\$191.00	\$238.00
Carpenter	\$146.00	\$192.00	\$237.00
Concrete Finisher	\$119.00	\$156.00	\$192.00
Laborer [Group 1]	\$103.00	\$131.00	\$159.00
Flag Person [Group 3]	\$103.00	\$131.00	\$159.00
Driver On-haul/Off-haul	\$68.00	\$101.00	\$135.00
Driver Onsite [Group 3]	\$118.00	\$150.00	\$183.00
Driver Lowbed [Group 4]	\$118.00	\$151.00	\$184.00
Mechanic [Group 4]	\$145.00	\$191.00	\$238.00
PG&E Certified [Group 2]	\$149.00	\$198.00	\$246.00
EQUIPMENT	Equipment mobilization additional when required	Column 1	Column 2
BACKHOES		One Operator Required - see rates above	
John Deere 310SL 4WD, 4-in-1 extendahoe, thumb & swinger	\$70.00		
John Deere 410L all 4WD, 4-in-1 extendahoe (12 Available)	\$75.00		
>>Attachment: Compaction Wheel	\$10.00		
>>Attachment: Auger & Bits	\$25.00		
>>Attachment: Hydraulic Breaker [Brk1]	\$75.00		
EXCAVATORS, Mini		One Operator Required - see rates above	
CAT 303.5E Zero Tail Swing, QC, Thumb-12"/18"/24" Buckets (5 Available)	\$60.00		
>>Attachment: Auger (9" or 12" holes)	\$15.00		
>>Attachment: Hydraulic Breaker [Brk0]	\$30.00		
Cat 305 - 18", 24", 36" Buckets (2 Available)	\$75.00		
>>Attachment: Hydraulic Breaker [Brk0]	\$30.00		
EXCAVATORS, Medium		One Operator Required - see rates above	
Takeuchi TB280 - 18", 24", 36" Buckets (2 Available)	\$90.00		
>>Attachment: Compaction Wheel	\$10.00		
Komatsu PC138 Zero Tail Swing-18",24",36" Buckets (5 Available)	\$120.00		
>>Attachment: Thumb or Compaction Wheel	\$10.00		
>>Attachment: PSM Rock Wall Grapple	\$15.00		
>>Attachment: Allied Hydraulic Breaker [Brk2]	\$80.00		
Takeuchi TB2150 - 18", 24", 36" Buckets	\$130.00		
Komatsu PC228/PC238 w/ 48" Bucket & Thumb (4 Available) <small>24" Trench bucket available</small>	\$150.00		
>>Attachment: Compaction Wheel	\$10.00		
>>Attachment: Grapple	\$25.00		
>>Attachment: Kent Hydraulic Breaker [Brk2]	\$80.00		

HYBRID HOURLY RATE TABLE

EQUIPMENT Equipment mobilization additional when required	Column 1	Column 2	Column 3
EXCAVATORS, Large One Operator Required - see rates above			
CAT 335FR w/ Bucket & Thumb (2 Available)	\$200.00		
>>Attachment: <i>Compaction Wheel</i>	\$10.00		
>>Attachment: <i>Hydraulic Breaker [Brk2]</i>	\$80.00		
Komatsu PC360-10 w/ Bucket & Thumb (4 Available)	\$200.00		
>>Attachment: <i>Compaction Wheel</i>	\$10.00		
>>Attachment: <i>Hydraulic Breaker or Shear [Brk2]</i>	\$80.00		
Komatsu PC490 w/ Bucket & Thumb (3 Available)	\$245.00		
>>Attachment: <i>Compaction Wheel</i>	\$10.00		
>>Attachment: <i>12,000 lb Hydraulic Breaker [Brk3]</i>	\$100.00		
Hitachi ZX870H w/2yd, 4.5yd, 6.6yd buckets & Ripper	\$340.00		
DOZERS One Operator Required - see rates above			
Komatsu D51 6Way Blade & Rippers	\$130.00		
>>Attachment: <i>Laser</i>	\$15.00		
>>Attachment: <i>GPS</i>	\$30.00		
Komatsu D61 6 Way Blade, Rippers, Intelligent Control (3 Available)	\$170.00		
CAT D6T 6 Way Blade & Rippers	\$195.00		
>>Attachment: <i>Laser</i>	\$15.00		
>>Attachment: <i>GPS</i>	\$30.00		
CAT D8T S.U. Blade & Rippers	\$270.00		
>>Attachment: <i>Laser</i>	\$15.00		
>>Attachment: <i>GPS</i>	\$30.00		
CAT D9T St. Blade & Rippers	\$330.00		
>>Attachment: <i>Laser</i>	\$15.00		
>>Attachment: <i>GPS</i>	\$30.00		
ROAD GRADERS/GRADING TRACTORS One Operator Required - see rates above			
John Deere 210LE 4X4 4-in-1 Box Scraper (4 Available)	\$70.00		
Takeuchi TL12V Highflow Tracked Skidsteer , 4-in-1 Bucket (4 Available)	\$80.00		
>>Attachment: <i>Auger (9" or 12" holes)</i>	\$15.00		
>>Attachment: <i>Lowe XR215 Trencher</i>	\$25.00		
>>Attachment: <i>Caterpillar SG36 Stump Grinder</i>	\$25.00		
>>Attachment: <i>Hydraulic Breaker [Brk0]</i>	\$30.00		
>>Attachment: <i>Caterpillar 24" Asphalt Planer Attachment</i>	\$65.00		
>>Attachment: <i>Road Widener FH-R1</i>	\$55.00		
>>Attachment: <i>Erskine Wood Chipper</i>	\$65.00		
NorAm 65E Grader	\$85.00		
CAT 160M -16' Blade & Ripper, All Wheel Drive	\$175.00		
>>Attachment: <i>Laser</i>	\$15.00		
>>Attachment: <i>GPS</i>	\$30.00		
CAT 14M- 16' Blade & Ripper	\$200.00		
>>Attachment: <i>Laser</i>	\$15.00		
SCRAPERS One Operator Required - see rates above			
CAT 615C II Paddlewheel 15yd	\$160.00		
CAT 631 27yd. Open Bowl (2 Available)	\$245.00		

HYBRID HOURLY RATE TABLE

EQUIPMENT	Equipment mobilization additional when required	Column 1	Column 2	Column 3
LOADERS		One Operator Required - see rates above		
Komatsu WA270-7 Wheel Loader 3 yd, Side Dump (5 Available)		\$120.00		
Komatsu WA320-7 Wheel Loader 3.5 yd & Forks (3 Available)		\$125.00		
Komatsu WA380-8 Wheel Loader 4 yd G.P. Bucket, 3rd Valve (1 Available)		\$135.00		
LOG SKIDDER		One Operator Required - see rates above		
Log Skidder CAT 518 Winch & Grapple		\$95.00		
SCREEN				
Manual Grizzly Screens (bare) (\$500/wk - \$1500/mo) (2 Available)		\$10.00		
POWER BROOMS		See Labor requirements per equipment		
Laymor - Self-propelled 8ft. Power Broom (5 Available)		\$65.00	One Laborer required - see rates above	
XBroom on Freightliner Street Sweeper		\$125.00	One Operator required - see rates above	
COMPACTION, Towed Type				
>>Sheepsfoot 4x4 Double Drum Attachment (4 Available)		\$35.00		
COMPACTORS, Self-Propelled		One Operator Required - see rates above		
CAT 815B/815F Tilt Blade (2 Available)		\$180.00		
CAT 825C/825H Tilt Blade (2 Available)		\$250.00		
>>Attachment: GPS		\$30.00		
ROLLERS, Smooth Drum		One Operator Required - see rates above		
Dynapac CC12001300 47" Dual Drum Vib. Asphalt Roller		\$65.00		
CAT CB-22B 39" Dual Drum Vibratory Asphalt Roller		\$65.00		
Bomag BW141 59" Double Drum Roller		\$85.00		
Bomag BW161 66" Double Drum Roller		\$100.00		
Volvo DD-90 66" Dual Drum Vibratory Asphalt Roller		\$100.00		
Volvo DD-110 66" Dual Drum Vibratory Asphalt Roller		\$105.00		
Volvo SD 115B Smooth Drum w/84" Pad Drum with Blade (4 Available)		\$105.00		
ROLLERS, Rubber Tire/Pneumatic		One Operator Required - see rates above		
Bomag BW11 RH (2 available)		\$95.00		
ASPHALT PAVERS		See Labor requirements per equipment		
Asphalt Power Curb Machine		\$35.00	One Laborer required - see rates above	
Seal Coat Machine		\$75.00	One Laborer required - see rates above	
Hot Crackfill Machine (Towable/requires pickup)		\$90.00	Three Laborers required - see rates above	
Blaw-Knox PF-545 Path Paver [#8]		\$230.00	Two Operators required - see rates above	
Carlson CP85 [#9,#12] or Bomag 814-2 [#11] (2 Available)		\$230.00	Two Operators required - see rates above	
Cat 1055F Paver [#10]		\$340.00	Two Operators required - see rates above	

HYBRID HOURLY RATE TABLE

EQUIPMENT Equipment mobilization additional when required	Column 1	Column 2	Column 3
CHIP SPREADER - Self Propelled	Two Operators Required - see rates above		
Rosco - 12' adjustable head	\$205.00		
WATER TOWERS			
Water Tower Model 10 or Interpipe 10,000 Gal. (Water extra) (2 Available)	\$10.00		
Water Tower Klein KPT120 12,000 Gal (Water extra) (4 Available)	\$12.00		
WATER TRUCKS			
Water Trailer-Towed Type - 500 Gal. Capacity (Water extra @\$5 per load) (4 Available)	\$20.00	Requires pickup and Laborer	
Water Truck 2000 Gal. Self Load - 2 axle (Water extra @ \$20 per 2k load) (3 Available)	\$80.00	One Driver required - see rates above	
Water Truck 3800-4000 Gal. Self Load - 3 axle (Water extra @\$35 per ~4k load) (7 Avail)	\$90.00	One Driver required - see rates above	
Water Truck Volvo A40F 7500g Off Road Articulated (Water extra) (2 Available)	\$200.00	One Operator required-see rates above	
HEAVY TRUCKS **ADD \$5/hr for Projects East of Bass Lake Road**	One Driver Required -see rates above		
Dump Truck - 6 Wheel	\$75.00		
Dump Truck - 10 Wheel, Rock Beds, 10yd. Capacity (2 Available)	\$80.00		
Dump Truck - Super Dump, 14 yd. Capacity (10 Available)	\$90.00		
Transfer Dump Truck w/Transfer Trailer (10 Available)	\$95.00		
Semi End Dump (lowside) 20yd Capacity (4 Available)	\$95.00		
Highside Semi End Dump w/ 32'-40yd or 36'-55yd (2 Available)	\$105.00		
Highside Semi End Dump w/ 40'-87yd (2 Available)	\$115.00		
OFF ROAD TRUCKS			
One Operator Required - see rates above			
Volvo A-40F & A40G 40 ton capacity (6 Available)	\$195.00		
Volvo A-45G 45 ton capacity (2 Available)	\$205.00		
EQUIPMENT TRANSPORTS - All required trip permits extra			
One Driver Required -see rates above			
Pilot Car w/signage & lights	\$40.00		
Hoe Hauler (12t capacity) or Roll Back Truck (2 Available)	\$90.00		
3Ax Tractor w/8W Lobed Trailer 38 Ton Capacity (2 Available)	\$105.00		
3Ax Tractor w/16W Lobed Trailer, Legal Loads (2 Available)	\$125.00		
3Ax Tractor w/16W Lobed, with/10'wide trailer (2 Available)	\$135.00		
3Ax Tractor w/16W Lobed & 7Ax Jeep or Scraper Basket	\$190.00		
UTILITY TRUCKS			
3/4 Ton Pickup Trucks <i>includes F150, F250 & F350</i>	\$30.00		
1 Ton Trucks & Superdutys <i>includes F450 & F550</i>	\$40.00		
PAT-1 24' Flatbed 2 Axle Truck	\$75.00		
PAT-1 24' Flatbed 2 Axle Truck with Attenuator	\$95.00		
TRAILERS			
Utility 1 Axle Trailer	\$5.00		
Utility 2 Axle Trailer	\$10.00		
Equipment Trailer	\$20.00		

EQUIPMENT Equipment mobilization additional when required	Column 1	Column 2	Column 3
ASPHALT CONCRETE SAWS			
Saw, Asphalt Concrete Handheld w/Diamond Blade	\$20.00		
Saw, Asphalt Concrete Husqvarna 4400-D/Merit 44HP (Large - requires pickup)	\$60.00		
Saw, Asphalt Concrete Wet 14" Walk Behind	\$50.00		
ASPHALT CONCRETE GRINDER		One Operator Required - see rates above	
Wirtgen W120Fi 48" Asphalt Grinder (Minimum Daily Rate)	\$2,720.00		
TRENCHERS		See Labor requirements per equipment	
Trencher - Ditch Witch Walk Behind	\$20.00	One Laborer required - see rates above	
Vacuum Fluid Excavator - Vacuum Truck 2100 PD	\$285.00	One Operator required - see rates above	
TELEHANDLER/FORKLIFT		One Driver Required - see rates above	
Telehandler All Terrain - Gehl RS5	\$70.00		
Telehandler All Terrain - CAT TL1055	\$90.00		
TOOLS/COMPRESSORS/NON-OP EQUIPMENT			
Air Compressor - Ingersoll Rand, Doosan (bare w/tools) (4 Available)	\$30.00		
Bituminous Oil Pot, 200gal (Material extra) (3 Available)	\$20.00		
Bituminous Oil Pot, 600gal w/Spray Bar (Material extra)	\$25.00		
Concrete Mixer	\$20.00		
Generator-Multiquip 25KW Portable (2 Available)	\$25.00		
Generator-Magnum 56KW Portable (1 Available)	\$35.00		
Generator-Small Portable	\$20.00		
High Pressure Washer - Apache 3000PSI	\$15.00		
Light Towers (trailer mounted) 4 Magnum & 4 Allmand diesel 4 lights	\$20.00		
Pump - Flygt 4" Sump - generator additional (3 Available)	\$15.00		
Pump - 3" Sump or smaller -generator additional	\$10.00		
Saws, Chain/Ring/Cut Off	\$20.00		
Sewer Camera	\$20.00		
Slurry Tanker, 800gal (Material extra)	\$25.00		
Wacker, Stomper Compactor	\$20.00		
Wacker, Vibratory Plate Heavy -Turtles	\$25.00		
Winch, WARN for Excavator Attachment	\$15.00		

EQUIPMENT Equipment mobilization additional when required	Column1	Column2	Column3
GPS			
GPS Base & Pole Equipment	\$15.00		
GPS Base & ATV/Pole Equipment	\$25.00		
GPS Base & Equipment Mount (GPS Equipment only)	\$30.00		
TRAFFIC CONTROL			
F550 Cone Truck & Cones (2 Available)	\$85.00	One Laborer required - see rates above	
Arrow Board - Daily Rate (8 hours) (4 Available)	\$125.00		
Arrow Board - Weekly Rate (40 hours)	\$400.00		
Arrow Board - Monthly Rate (160 hours)	\$925.00		
Message Board - Daily Rate (8 hours) (10 Available)	\$165.00		
Message Board - Weekly Rate (40 hours)	\$400.00		
Message Board - Monthly Rate (160 Hours)	\$1,250.00		
AFAD - Automatic Flagger (8 hours per each unit) (2 Available)	\$200.00		



Rockwell Automation Contract Renewal

To renew support for another year, please review this quote and instructions below.

If no changes are required, please follow the purchase order instructions outlined in Section 2.3.

If changes are required before purchase, please contact your local Rockwell Automation Distributor.

Rockwell Automation Services Agreement - Renewal

FIXED PRICE PROPOSAL

3801063919

Rancho Murieta Community Servis District
Rancho Murieta, CA

Date of Issue: Tuesday, March 24, 2026
Quotation #: 376576 (RA Approval - QXSK10533A)

Presented to:
Rancho Murieta Community Servis District
15160 Jackson Road
Rancho Murieta, Ca 95683
United States

Proposed by:
Rexel USA, Inc.
1534 N Market BLVD
SACRAMENTO, CA 95834
United States

*Rockwell Automation
Unknown
Unknown
Unknown, Unknown Unknown
United States*

expanding **human** possibility®

Contents

1	ROCKWELL AUTOMATION STATEMENT OF WORK FOR SERVICES.....	4
1.1	TechConnectSM Support Agreement.....	4
1.1.1	Agreement Term.....	4
1.1.2	TechConnect SM Support Levels	4
1.1.3	Product Coverage Details	4
1.1.4	TechConnect SM Support Information	5
1.1.4.1	TechConnect SM Support Options.....	5
1.1.4.2	Definitions of Common Terms Used in Services	7
1.1.4.3	Product Families	7
1.1.5	Learning+ Subscription (Optional).....	8
1.1.5.1	Solution Description	8
1.1.6	Changes to Agreement.....	8
1.1.6.1	Updates to Supported Software Installed Base	8
1.1.6.2	Upgrade Options.....	8
1.1.6.3	Changes to Scope	8
1.1.6.4	Reinstatement Policy	8
1.1.7	Product Coverage Exclusions	9
1.2	Customer Responsibilities.....	9
1.2.1	Maintenance, Electrical, and Operations Staff	9
1.2.2	System Maintenance and Use	9
1.2.3	Access to the System	10
1.3	Assumptions, Clarifications and Exceptions	10
1.4	TechConnectSM - Termination for Convenience.....	12
1.5	Rockwell Automation Commitment for Sales Through Distribution.....	12
2	DISTRIBUTOR COMMERCIAL TERMS.....	13
2.1	Pricing Summary	13
2.2	Invoicing Schedule	13
2.3	Purchase Order Instructions	14
2.4	Distributor Terms and Conditions of Sale	14

1 Rockwell Automation Statement of Work for Services

This proposal is offered to Rexel USA, Inc. for resale to Rancho Murieta Community Servc District (“Customer”).

1.1 TechConnectSM Support Agreement

This TechConnectSM Support Agreement (“Agreement”) allows plants to be connected to Rockwell Automation’s world-class phone and electronic technical support.

Rockwell Automation’s technical support team will provide assistance with installing, configuring and maintaining equipment and software, obtaining current software updates, diagnosing and fixing operating problems, or performing basic programming tasks.

1.1.1 Agreement Term

Agreement Coverage Period: Thursday, July 16, 2026 to Thursday, July 15, 2027

1.1.2 TechConnectSM Support Levels

Product Family	Description	Support Level	Service Level
9800-DC8AUTOA	Automation Control Hardware	Product Support	8 x 5 M-F
9800-DC8HMICOM	HMI Software	Product Support	8 x 5 M-F
9800-DC8INFAUT	Information Automation Software	Product Support	8 x 5 M-F

Table 1: TechConnectSM Support Levels

1.1.3 Product Coverage Details

Rockwell Automation will provide TechConnectSM Support coverage to Customer for the Rockwell Automation Product Families & software serial numbers listed below. Please ensure the following information is complete and includes any new “Software Maintenance” products you wish to add to this support agreement.

Hardware Type
Automation Control Hardware

Product Family & Software Serial Numbers	Description	Install Count
9800-DC8HMICOM	HMI Software	
9701-VWSCWAENE		1

The information contained in this document consists of technical, commercial and/or financial information, which is confidential and proprietary to Rockwell Automation, Inc. This information is furnished in confidence and with the understanding that it may not be disclosed to third parties or reproduced or used, in whole or in part, for any purpose other than evaluation of this document.

Product Family & Software Serial Numbers	Description	Install Count
2524123225	FT View Client Site Edition ESD S/W	1
9701-VWSCWAENW		2
2524095926	FT View Client Site Edition ESD S/W	1
2524095927	FT View Client Site Edition ESD S/W	1
9701-VWSS100AENW		1
2527025728	FT View Server SE 100D License ESD S/W	1
9701-VWSS250AENE		2
2528016241	FT View Server SE 250 Display Lic sfw	1
2528016242	FT View Server SE 250 Display Lic sfw	1
9701-VWSTENW		1
2529047546	FT View Studio SE FT View Ent EN ESD S/W	1
9800-DC8INFAUT	Information Automation Software	
9518-HSE500W		1
3318005960	FT Historian SE - 500 tags ESD Software	1
9521-VPCL01ENW		1
3127005794	FT VantagePoint Client 1 CCU ESD S/W	1

Note: If changes to the TechConnectSM Support Product Coverage Details above are required, please contact your local Rockwell Automation sales office or Allen-Bradley® authorized distributor to request an updated proposal.

1.1.4 TechConnectSM Support Information

1.1.4.1 TechConnectSM Support Options

Rockwell Automation offers progressive levels of support to meet your business needs; see table below for all available support level options. Please refer to *Table 1: TechConnectSM Support Levels* regarding support levels included in this Statement of Work.

Support Level	Support Services Description
Application Support	<p>You are partnered with a team of technical support engineers who are uniquely designated to support your key applications. This team visits your site, becomes familiar with the applications, and gathers system drawings and documentation. This team will become an extension of your support staff, providing technical account management and scheduled consulting time.</p> <p>Application Support includes the support elements of Product Support, System Support and the following support elements:</p> <p>Real-time, Application-Level Support <i>Designated support team / Dedicated telephone and email / Documentation and case familiarization / Application knowledge management / Periodic performance reviews</i></p> <p>Surveillance and Alarming Options <i>Device and/or process monitoring and alarming at Rockwell Automation facility or remotely / Access to historical data for troubleshooting</i></p> <p>Application-Level Administration Option</p>

The information contained in this document consists of technical, commercial and/or financial information, which is confidential and proprietary to Rockwell Automation, Inc. This information is furnished in confidence and with the understanding that it may not be disclosed to third parties or reproduced or used, in whole or in part, for any purpose other than evaluation of this document.

Support Level	Support Services Description
	<p><i>Emergency backup / Performance tuning / Guaranteed field service call-out</i></p>
System Support	<p>System Support allows your calls to be routed to a group of technical support engineers with proven expertise in Rockwell Automation control systems. You will work with an engineer who manages your case through resolution and follow-up.</p> <p>System Support includes the support elements of Product Support, and the following support elements:</p> <p>Real-time, System-Level Support <i>Standard product and programming software / Advanced software / Proactive follow up / Single-point resolution</i></p> <p>Advanced Engineering Expertise <i>Get support from system-level support engineers that have multiple years of experience in the industrial automation industry</i></p>
Product Support	<p>As often as Customer needs require, you can contact Rockwell Automation technical support engineers for real-time phone support. Our engineers have deep knowledge of our products, software and legacy hardware and can use remote desktop technology to help troubleshoot or assist in the configuration of products quickly.</p> <p>Product Support includes the support elements of Self-Assist Support, and the following support elements:</p> <p>Real-Time, Product-Level Support <i>Standard product and programming software / Telephone and live chat support available in 20 languages / Remote desktop troubleshooting</i></p> <p>Learning+ Subscription Available for Purchase <i>Highly interactive learning featuring lessons, software simulations, and demonstration videos to help reinforce learning concepts. Available on any tablet or PC using Chrome, Safari, IE, Edge or Firefox. Each course has a knowledge assessment, requiring 80% to pass. Upon successful completion of the course, a learner will be awarded CEUs (where applicable).</i></p> <p>Live View <i>An enhanced support experience connecting you with a Rockwell Automation Technical Support expert leveraging a live video feed, content sharing, and annotations in real time.</i></p> <p>Software Maintenance II</p>

Support Level	Support Services Description
	<i>Software update media / Emergency software replacement</i>
Self-Assist Support	<p>Take advantage of the Knowledgebase, an online resource for technical information, support, and assistance. The Knowledgebase can assist in increasing productivity by finding solutions to technical questions more quickly - saving both time and money. The KnowledgeBase is maintained by the same engineers who provide TechConnectSM Support and is updated with the hardware and software solutions from actual support cases. These updates are incorporated dynamically. Self-Assist includes the following support elements:</p> <p>Welcome Kit <i>Essential support agreement information / Support authorization number / Local support telephone number / User guide</i></p> <p>Digital Assist Library <i>Cloud-hosted augmented reality library of work instructions. Leverage augmented reality to walk through the proper steps to complete tasks related to the repair and maintenance of Allen-Bradley hardware</i></p> <p>Software Maintenance I <i>Software update downloads</i></p> <p>Online Support Centre Access <i>Knowledgebase tech notes / Interactive forums / Product notifications / Manage service tickets / Submit questions via email</i></p>

1.1.4.2 Definitions of Common Terms Used in Services

Technical Phone Support: Rockwell Automation phone support provides technical assistance for installation, configuration, troubleshooting, diagnosis, basic instruction programming and best practice recommendations. With an unlimited phone support agreement, Customer can call as often as needed throughout the term of your Agreement. Standard hours of coverage are 8:00 AM to 5:00 PM Monday – Friday (based on your local calling time; Rockwell Automation observed holidays excluded). Information on Rockwell Automation observed holidays can be found via the Knowledgebase in article #QA33258 (https://rockwellautomation.custhelp.com/app/answers/answer_view/a_id/819086/redirect).

Case Handling: Rockwell Automation handles cases that require further investigation as a priority with automatic escalation procedures, and call Customer back to provide a progress update if an answer is not immediately available.

Case Resolution Follow-up: For cases where Rockwell Automation could not confirm resolution on the initial call, Customer will receive a proactive follow-up within one business day (target response) to confirm that the problem was resolved or continue troubleshooting, if necessary.

1.1.4.3 Product Families

Rockwell Automation groups products into product families, making it simpler to deliver integrated support for hardware and software, including older and discontinued products. The lists available at the following link are not comprehensive; however, they illustrate how products are classified.

[TechConnect Support Product Family Coverage | Rockwell Automation | US](https://www.rockwellautomation.com/en-us/capabilities/industrial-maintenance-support/product-application-support/remote-support/product-family-coverage.html)

<https://www.rockwellautomation.com/en-us/capabilities/industrial-maintenance-support/product-application-support/remote-support/product-family-coverage.html>

1.1.5 Learning+ Subscription (Optional)

1.1.5.1 Solution Description

Rockwell Automation offers Learning+, an online training platform accessible on any internet enabled device. Options offered for sale include either short term access to a single automation course or an annual subscription. An annual Learning+ subscription provides modular, self-paced lessons, on-demand webinars, and unlimited access to scheduled Virtual Instructor Led Training Courses.

1.1.6 Changes to Agreement

1.1.6.1 Updates to Supported Software Installed Base

Support included with new Licenses purchased during the agreement term are not covered by this scope of work. Each new software purchase includes an independent support contract which may be co-termed with your TechConnect anniversary date. Renewal of these purchases will occur in the Rockwell Automation commerce portal as a separate agreement.

Please work with your Rockwell Automation Customer Success Manager during each TechConnect renewal to consolidate and extend existing contracts to your next TechConnect renewal date.

1.1.6.2 Upgrade Options

Updates to existing TechConnectSM Support Agreement and/or upgrades must be custom quoted by Rockwell Automation. Customer has the following upgrade options:

Coverage Level: Product and System Support agreements can be upgraded to 24x7x365 coverage (e.g., 8:00AM – 5:00PM to 24x7x365), which provides the option to call at any time, including weekends and holidays.

Support Level: Customer may upgrade support levels (e.g., Product Support to System Support) during the term of an existing agreement.

1.1.6.3 Changes to Scope

Contact your local Rockwell Automation sales representative if any adjustments are required during Agreement term, such as:

- Adding or removing a site from support
- Moving supported equipment and software to another supported facility
- Closing a plant and selling to another entity

1.1.6.4 Reinstatement Policy

If Customer does not renew their contract until after the expiration date of the contract, the Customer has the following options to reinstate their support:

- a. If an agreement is not renewed on time and it has been less than 12 months since expiration, the renewed agreement will be backdated to the original expected start date and a 10% fee¹ will be added to the cost of the renewal.
- b. If an agreement is not renewed on time and it has been longer than 12 months since expiration, the support agreement will be priced as a new agreement with current price levels and any previous discounts will not be applied.
- c. For software packages that are removed from support and later reinstated, often referred to as “frozen” and “unfrozen,” a 30% premium will be applied to each piece of software which carries a fee for maintenance as part of the TechConnectSM program.

Note: There is a grace period of 10 days after the date of the Agreement expiration during which Customer can still access support. If Customer renews after the expiration date of the Agreement, the policy above applies regardless of this grace period.

1.1.7 Product Coverage Exclusions

Rockwell Automation products excluded from TechConnectSM Support coverage under this Agreement (if applicable) are listed below:

1.2 Customer Responsibilities

1.2.1 Maintenance, Electrical, and Operations Staff

When applicable, Customer will provide dedicated and available appropriate personnel knowledgeable in the process, operation, control system, and facility layout to assist Rockwell Automation personnel during onsite visits. They will remain onsite and available as necessary for project and/or safety reasons.

1.2.2 System Maintenance and Use

Customer is responsible for (i) the overall performance and overall design of the machine or manufacturing system, including safety features failure modes; (ii) properly using, calibrating, operating, monitoring and maintaining the products and system consistent with all Rockwell Automation or third-party provided instructions, warnings, recommendations, and product and system documentation; (iii) ensuring that properly trained personnel use, operate and maintain the products and system at all times; (iv) staying informed of product updates and alerts and implementing all updates and fixes; (v) notifying Rockwell Automation of any problems with the products or system; and (vi) all other factors affecting the products or system that are outside of the direct control of Rockwell Automation.

¹ If Customer’s TechConnectSM Support Agreement has never included support for the product family in question, then the commercial “waive reinstatement” program applies for the respective packages.

1.2.3 Access to the System

Customer will make the applicable processes and/or systems available to Rockwell Automation personnel during the mutually agreed upon schedule for services and equipment implementation as described in this Statement of Work.

1.3 Assumptions, Clarifications and Exceptions

The following assumptions, clarifications and exceptions have been made by Rockwell Automation in the development of this Statement of Work:

Reference	Assumptions (A), Clarifications (C) and Exceptions (E)
A1	Safety. All aspects of mechanical, electrical, and process safety are responsibilities of Customer.
A2	Installation. If applicable, all mechanical and electrical installation is to be provided and managed by Customer and their selected Contractor.
C1	Quotation Scope. Any elements not explicitly outlined within this Statement of Work are not included in the deliverables for this Rockwell Automation Services Agreement.
C2	Documentation. All project and system documentation will be in English and furnished in electronic format unless otherwise stated. Translation into other languages is not included in this Statement of Work.
C3	RoHS. Customer supplied/specified products will meet all applicable material restrictions as defined in RoHS. If it does not, Customer will notify Rockwell Automation prior to shipment of Customer supplied/specified products to Rockwell Automation. Customer will indemnify Rockwell Automation against any claim arising out of Rockwell Automation's use of Customer supplied/specified products.
C4	Existing Devices. Customer represents that any existing operator, machine-mounted, or field devices that are in use or are to be reused are in good working order and will be repaired or replaced by Customer when required. Repair and/or replacement of damaged devices is not included in Rockwell Automation's Statement of Work.
C5	Documented Change Request (DCR) Process. Changes to this scope of work requested by Customer throughout the duration of the Support Agreement will be identified and communicated through project management at Rockwell Automation. Estimates for the material costs, labor, and schedule impacts will be prepared when a change in scope is identified. Refer to the Rockwell Automation Changes provision for additional terms.
C6	Customer Specific Requirements. This proposal does not include Customer specific requirements or onsite activities such as Customer or site specific safety training, background checks, health-related testing or vaccinations, international work visas, and copies of expense receipts. Rockwell Automation must be made aware of any such requirements prior to contract award. Costs for associated time and expenses incurred while complying with such requirements will be at Customer expense.
C7	Infectious Disease Planning. Rockwell Automation is committed to health, safety, and doing all we can to maintain a high level of service for our customers. We are committed to communicating with you about the impact that an infectious disease and any related governmental restrictions may have on the deployment of our personnel and delivery of the project and truly appreciate your cooperation and understanding. In submitting any purchase order, you acknowledge and agree that Rockwell Automation will be excused from performance, or delay in performance, of its obligations under this purchase order, regardless of whether a contract is currently in place governing the parties' relationship, to the extent that Rockwell Automation is unable to perform such obligations due to the effects of a known infectious disease affecting Rockwell Automation and/or third parties, including, without limitation, logistics and materials suppliers.

C8	On-site Working Hours. Rockwell Automation Standard working hours may differ by country. Contact your local Rockwell Automation Distributor or Sales Office to obtain current local standard working hours.
C9	Stand-by time is defined as time spent on-site waiting for completion of customer activities. This includes, but is not limited to, waiting for correction of construction, installation, and wiring or piping errors, and other delays beyond the control of, or not within, Rockwell Automation's specific responsibilities. Stand by time will be invoiced separately at applicable time and expense rates.
C10	Work Site Safety. Customer is responsible for assuring a safe and secure work environment, compliant with relevant local, state, provincial, and nationally recognized standards and regulations, for work at the site.
C11	Safety and Substance Abuse. Rockwell Automation will comply with its own Substance Abuse Policy which meets the intent of the DRUG FREE WORKPLACE Act and all other legal requirements regarding drug testing. A copy of this policy can be supplied upon request.
C12	Ethics and Compliance. All of Rockwell Automation's employees and every person who performs work for, or on behalf of Rockwell Automation are treated with respect and dignity. Rockwell Automation has a no-tolerance policy for discrimination, harassment, and zero tolerance for workplace violence and weapons. Please see the PartnerNetwork Code of Conduct and the Rockwell Automation Global Policy People for further details. https://www.rockwellautomation.com/en-us/company/about-us/sustainability/ethics-compliance.html .
C13	Third Party Software. This Statement of Work may include third party software that is subject to third party license terms ("Third Party Software"). Customer's right to use such Third Party Software as part of or in connection with the Work is subject to any applicable acknowledgements and license terms accompanying such Third Party Software contained therein. If there is a conflict between the licensing terms of such Third Party Software and this Statement of Work, the licensing terms of the Third Party Software shall prevail in connection with the related Third Party Software.
C14	<p>Information Security Standards In the performance of all Work pursuant to this Agreement and Statement of Work, Customer and Rockwell Automation will comply with the following standards and practices:</p> <p>Data Transmission Customer agrees that all transmission or exchange of sensitive data with Rockwell Automation shall take place using secure, industry acceptable, standards (e.g., password-protected, using a complex password; encrypted WinZip sent via e-mail, or, for large files, an encrypted file transfer service; physical media such as paper/DVD sent securely; or another equally secure means of transport). If Customer requires Rockwell Automation to use Customer specified system, the security of the data in transit and at rest once sent from Rockwell Automation is Customer's sole responsibility.</p> <p>Customer-Provided Hard Disk If Rockwell Automation personnel are required to use Customer provided hard disks, Customer agrees to provide the hard disk with designated backup and recovery processes and in encrypted form, using commercially supported or industry standard open-source encryption solutions. The Customer must use commercially reasonable efforts to prevent the Customer-provided hard disk from introducing any malicious software into Rockwell Automation's systems. These efforts shall include, but are not limited to, the use of anti-virus and/or anti-malware and the regular deployment of security patches to remediate any vulnerabilities.</p> <p>Remote Access Remote access by Rockwell Automation's personnel into Customer's control system(s) must be accomplished in accordance with either Customer or Rockwell Automation procedures, whichever is more stringent. If Customer requires Rockwell Automation personnel to use Customer-specified procedures, the security of the connection/session is Customer's sole responsibility, and Customer is solely responsible for logging activities of all users accessing the Customer's system.</p>

C15	Cybersecurity for Solutions. Sub-contractors and/or third-party vendors will follow any applicable industry best practices and/or guidelines for cybersecurity and data protection with regard to IEC 62443 2-4.
C16	Personal Data. To the extent Rockwell Automation processes personal data in the performance of the services under this Statement of Work, such processing of personal data will be conducted in accordance with the Data Processing Addendum ("DPA") available at https://www.rockwellautomation.com/en-us/company/about-us/legal-notices/data-processing-addendum.html .
C17	Customer Information. Rockwell Automation will share with its authorized distributor or partner of record Customer Data collected under this Agreement pursuant to the terms herein and the Rockwell Automation Privacy and Cookies Policy located at https://www.rockwellautomation.com/en-us/company/about-us/legal-notices/privacy-and-cookies-policy.html .
C18	Customer Success Publication. Sharing customer success stories helps position customers as leaders among companies pursuing excellence in their industrial operations. Customer agrees that Rockwell Automation can reference and disclose Customer's name and logo in internal and external marketing materials and will share only the solutions and services purchased, Customer industry, location, and general results through a customer success story. Rockwell Automation will make no claims that Customer endorses the product or solution, and the success story will be used for marketing purposes only.

1.4 TechConnectSM - Termination for Convenience

Either party may terminate this Agreement with a prior written 30-day notice. In the event Customer cancels, Customer would be subject to a termination fee equal to 25% of the remaining Agreement value. Termination request is invalid if remaining term of service is less than 2 months.

1.5 Rockwell Automation Commitment for Sales Through Distribution

The Rockwell Automation Commitment for Sales Through Distribution (the "Commitment Terms") found at <https://www.rockwellautomation.com/en-us/company/about-us/legal-notices/commitment-for-sales-through-distribution.html> covers purchases by Distributor's customer ("Customer") from Distributor of the Products and Services described and integrated pursuant to this Statement of Work to be provided by Rockwell Automation, Inc. and/or its affiliates. The Commitment Terms apply directly to Customer and Rockwell Automation.

Accepted.

Customer: _____

Date: _____

2 Distributor Commercial Terms

2.1 Pricing Summary

Rexel USA, Inc.'s price is based on the Statement of Work set forth in Section 1 above. All prices are in USD.

Item	Product	Price
1	9800-DC8AUTOA <i>Automation Control Hardware, Product Support, 8 x 5 M-F, 1-4 Total Devices</i>	1,106.75
2	9800-DC8HMICOM <i>HMI Software, Product Support, 8 x 5 M-F</i>	7,974.97
3	9800-DC8INFAUT <i>Information Automation Software, Product Support, 8 x 5 M-F</i>	3,169.67

TOTAL PRICE: **USD 12,251.39**

Contract Reinstatement Fee: USD 1,225.14

If this contract is not renewed before the current Contract Expiration Date Thursday, July 15, 2027, a 10% Contract Reinstatement Fee will be applied to the Suggested Resale Price.

Multi-Year Option - Fixed Price 3-Year Contract

One-Time Payment or Billed Annually - Single PO for 3-Year Amount Required **\$36,754.17**

LEARNING+ SUBSCRIPTION (OPTIONAL): Web hosted, self-paced training courses including virtual classroom sessions are available for customers with an active TechConnect support agreement, as either single course access or annual subscription to all course content available in the Rockwell Automation Digital Learning Library. Please add the net amount for the Learning+ option desired in the correct quantity of desired users to your renewal PO.

Catalog Number	Description	List Price per User
LP-3TC	Learning+ 1 Class available for 3 months	USD 820.00
LP-SU1	Learning+ Single User Subscription	USD 4,940.00

2.2 Invoicing Schedule

Contract Start Date

2.3 Purchase Order Instructions

Please Issue a Single Purchase Order to: Rexel USA, Inc.
Ref: Proposal # 3801063919

Purchase order should match the value and term proposed above. If a purchase order received does not match the term of the agreement, pricing will be subject to annual price adjustments.

2.4 Distributor Terms and Conditions of Sale

All sales are subject to Rexel's Terms & Conditions of Sale in effect at the time of the quotation. Rexel's Terms and Conditions of Sale are available at www.rexelusa.com/terms or available upon request from your local Rexel representative. This quotation supersedes all pervious quotations relating to this transaction. Due to market conditions, all products or items set forth in this quotation are subject to price increases through time of shipment unless this quotations expressly states that pricing for any such products or items if firm and fixed. If services are included in this quotation, in addition to Rexel's Terms and Conditions of Sale, the services are also subject to the actual service provider's terms and conditions applicable to such services.

PROPOSAL



PROPOSED HARVESTING OF AQUATIC VEGETATION AT LAKE CHESBRO - RANCHO MURIETTA

Estimated project start date: August 24th 2026

Each Harvester and Crew:	\$1850 per day
Truck, Conveyor Trailer and Crew:	\$400 per day
Transport each Harvester:	\$600 each way
Crew Lodging:	\$500 per day

Three days of lake cleaning estimated at \$15,000 for two harvesters and truck, trailer and crew.

*Minimum of three days of work required with two harvesters
Includes Harvester, Crew, Fuel, and Lodging.
Subject to full terms and conditions of the full Proposal*

May 20, 2026

Re: Proposal for Aquatic Plant Chopping and Harvesting at Retention Pond.

Aquatic Harvesting Inc. is pleased to submit the following proposal to harvest the excessive aquatic plants from Lake Chesbro in Rancho Murietta.



We are based near San Francisco with clients in Arizona, California, Oregon, Washington, Idaho and Texas. Our staff is highly valued for their excellent customer service. We enjoy our work and provide an excellent service at a fair price.

Our crew and equipment have harvested a diverse variety of aquatic weeds from lakes, ponds, rivers, and deltas across the Western and Southern states. We are certain that we can provide you with the aquatic harvesting service you seek. If at any time you are not satisfied, tell me. The concern will be corrected, or you will not be charged for the work that day.

We operate a diverse set of aquatic vegetation removal equipment. Harvesters, Transport barges, Herbicide Applicator boats, an Aquatic Vegetation Cutter (AVC aka "Swamp Devil") and support equipment like Trucks, Trailers, Conveyors, and herbicide application boats. With our AVC (*Aquatic Vegetation Cutter*), we remove difficult shoreline plants like Bulrush, Cattail and Primrose along with their root structure. With our harvesters we cut and remove aquatic plants to a depth of nearly six feet.



Proposal For Aquatic Vegetation Removal:

Aquatic Harvesting inc. proposes to utilize an aquatic weed harvester to cut and remove the aquatic weeds found throughout Lake Chesbro. The harvesters are easily launched at your boat ramp or soft sloped shoreline. No disturbance to normal lake uses or fish / wildlife is anticipated.

Our harvesters automatically cut and collect the aquatic plants. When the Harvester becomes full of plants, it will return to the ramp and offload the cut material onto our specially designed conveyor-trailer. The harvested plants can be left on the ground to dry or immediately be transported to a disposal site. The value of drying the aquatic plants to reduce their weight and thereby reduce the disposal fees. When transporting the plants on city streets, we usually cover the load with a tarp to minimize spilling.



Harvester and Operator Fee:

Each lake is different, and the volume and type of plant can vary. Within the same lake, some areas are thick with plants, while other areas are sparse. Therefore, it's difficult to estimate the area that can be harvested in a day. But on average we harvest up to two acres each day per harvester. To be fair and stabilize expectations, we charge a daily rate for our equipment. If someone thinks we are not working effectively, then alert me and the concern will be corrected, or you will not be charged for that day. We are happy to explain what we are doing and why and offer to take folks on the harvester to help them understand the process. Working closely with your staff and providing daily verbal reports is welcome.



Disposal Fee:

In previous visits we moved the material to a nearby field for decomposing / composting. If this remains available to us there will be no disposal fee.



Travel Expenses:

We propose to be reimbursed for our travel expenses. This includes transporting equipment as well as residing near the job site. We can estimate or itemize these expenses on the invoice. We don't seek to profit from this, just cover our expenses. Estimate is \$150 per crew per day.

We estimate \$500 per boat each way to deliver or remove the equipment. This includes driver wages and fuel. A full day of driving is about \$1000 per harvester/truck. (\$400 fuel, \$200 food/lodging \$300 wages).



Equipment:

For this project we intend to use "H8" harvesters. This boat travels well and is reliable. Our equipment runs great and is specially modified to operate quietly and carefully to bring minimal disturbance to your community.

The harvester has a cutting width of 8' and a cutting depth of nearly 6'. It has a storage capacity of about 230 cubic feet. This unit is hydraulically powered with a Yanmar or Kabota diesel engine. Three-inch steel blades will be used to cut the underwater plants, and conveyor belts immediately remove cut vegetation from the water.

As a safeguard, our equipment utilizes vegetable-based Bio-Fleet™ biodegradable hydraulic fluid. This fluid meets the Environmental Protection Agency guidelines for Environmentally Acceptable Lubricants, exceeding the acute toxicity (LC-50 / EC-50 >1000 ppm) criteria adopted by the US

Fish and Wildlife Service and the US EPA. Aquatic Harvesting inc. pays extra expense with this fluid as an extra precaution to protect your waterways.

Additionally, hydraulically controlled “conveyor trailers” can be provided with a four-wheel drive truck to safely transport the harvested biomass to a nearby disposal site.



Cost and Deliverables:

Based on the above proposal, we offer the following per day rates:

- Harvester, fuel and operator: \$1850 per day per boat
- Optional - Conveyor trailer with 4WD drive truck and driver: \$400 per day
- Travel Expenses (*itemized or estimated*)
 - Equipment and crew transport (*fuel, food/lodging, wages*): \$600 / harvester each way
 - On site (*food/lodging*) \$167 per day per crew

We strive to offer our services at a fair price. We're a fifteen-year-old company that's raising expectations by providing a skilled crew, well maintained equipment and going the "extra mile" to insure happy customers.

Tasks and Schedule:

Below is a summary of the tasks and sub-tasks that we will perform at each harvest, and the schedule. As you will note by comparing the list of tasks (below) and the list of deliverables, Aquatic Harvesting Inc. often elects to not charge for some tasks

- Mobilization
 - Deliver Equipment to your job site.
- Cutting and Harvesting
 - Cut aquatic vegetation at sites designated by your staff.
 - Transport cut vegetation to your disposal site.
 - Moving equipment between job sites.
- De-mobilization
 - Clean-up work area and remove equipment.

Assumptions:

All underwater pipes, conduits, electrical wires, communication lines, aeration lines, irrigation lines, morning lines and other obstacles must be marked and discussed with the operator prior to harvesting. Aquatic Harvesting Inc. will not be liable for damage caused by our equipment or employees to obstacles that are unknown or unmarked.

Conclusion:

If you have any questions regarding this Proposal or the Scope of Work, or you need additional information, please call me. Aquatic Harvesting Inc. has a fleet of specialized equipment to keep your waterways and shorelines in good condition and free of aquatic plants.

We welcome the opportunity to help you maintain your waterways year 'round.

Sincerely,



Rick Hatton

Aquatic Harvesting Inc.

925-786-0095

rick@aquaticharvesting.com

AVAILABLE EQUIPMENT

2001 Model HM-420 Harvester

This has only 500 hours of operation and is in near new condition. It holds 460 cubic feet of vegetation. It has a stainless steel hull and is powered by a Hatz diesel engine. With its large payload capacity, it is selected when large loads are anticipated or there's a long distance between offloads.



2002 Model H8-220 Harvesters

We have two of these harvesters. This model is the “work-horse” of the harvesting industry. It's an operator favorite because of the high reliability and versatility. It excels in lakes, ponds, marinas and rivers. These harvesters have removed up to twice the volume of plants per hour than larger harvesters due to their strength, speed and maneuverability. These can be outfitted with 20' x 1.5' “pusher blades” to push large volume of floating plants (i.e. hyacinth & pennywort). We believe that this size is a fastest and most nimble harvester available. It is powered by a 45 HP John Deere diesel engine or a 35 HP Kubota diesel engine.



Aquarius T12 Transport Barge

This is helpful in operations where trips from the harvesting area to the off-load site are long distance. With the T12 Transporter, our Harvesters can off-load into this transport barge and eliminate travel to and from the dump area.

The transport barge improves large project efficiencies by working like a “dump truck”, carrying cut plants from the harvesting area to the off-load point. This transporter carries 650 cubic feet of vegetation. It is propelled quickly with two propellers and powered by a Hatz diesel engine.



“AVC” Aquatic Vegetation Cutter

The **AVC** excels at removing Tule, Cattail and Bulrush plants. This machine excels in wetland maintenance. It quickly cuts shoreline plants and their root structure, with twin four foot diameter rotating blades. This rare craft is powered by high torque Cummins diesel engine.

(Google: “Aquatic Harvesting AVC” for video of this equipment).



Shore Conveyor

This conveyor has 6.5' wide galvanized flat-wire belting that reaches 28.5' and a height of 9.5'. It can be towed to the job site and set up in minutes. It is hydraulically controlled and is powered by a new Briggs and Stratton 23 HP gas engine. It has minimal usage and is in excellent condition.

Shore conveyors are used to transfer harvested vegetation into dump trucks.



Levy Conveyor

We have three new "Levy Conveyors". Each conveyor can be adjusted at the job site to match a varying slope on dirt and/or rock covered levies. Together, these hydraulically powered conveyors move material up a levy wall and across land, up to a distance of 60'.

Pontoon, Inflatable and Ridged Jon Boats

These are stable platform for applying aquatic herbicides as well as non-herbicide methods for removing "blue green algae". Some boats are equipped to automatically spread granular or powder material in twenty-foot diameter stripes with our proprietary applicator. This boat is often used by municipal water districts to apply Phycomycin to remove blue-green algae.

It can also be used as a material and crew transport vehicle.

Since much of our work occurs within environmentally sensitive areas, we utilize biodegradable **plant based hydraulic fluid** that meets stringent USCG standards. All of our equipment is well maintained and ready for work.



May 20, 2026

Pollution Prevention / Spill Response Plan

Aquatic Harvesting Inc. utilizes mechanical harvesters to remove aquatic vegetation and other debris from ponds, lakes, and other waterways. Our equipment is powered by diesel engines which in turn provide torque to a hydraulic system. Diesel fuel, engine oil, engine coolant and hydraulic fluid would be the source of pollution caused by a harvester. We are aware of and strive to minimize these dangers.

Our equipment is well maintained. Our operators are trained to inspect the equipment throughout the workday. If a fluid leak is noticed, the equipment is shut off and its source is found. Leakage of diesel engine fluids (oil, fuel, coolant) is extremely rare. The only instance we know of was from a boat that rolled over. To prevent this, our operators are repeatedly reminded of what causes a "roll".

Hydraulic fluid leaks do occur, but this can be minimized and usually prevented. The most common hydraulic fluid leak is caused by a burst hydraulic hose or loose hose fitting. To prevent this from occurring we inspect the hoses and replace any that show excessive wear. Hoses that rub against metal are protected by plastic plates on area of rub. We carry spare hoses with each harvester in case of a defective hose. If a hose bursts the operator is alerted by the sound of oil escaping and or a smell. A burst hose causes the boat to be shut off and then the hose is replaced. Area that has oil is cleaned with Dawn soap, towels, and oil absorption blankets.

The other source of hydraulic fluid leakage is a defective hydraulic cylinder or motor seal. These fail slowly and at first are noticed by an oily residue around the shaft but can grow to a few drops per minute if unchecked over a period of days. Operators inspect all shafts at the beginning of each shift. Throughout the day, the operators also monitor the boat hull and water around the boat for an oily sheen. This can be noticed very quickly, after just a few drops in the water by an alert operator. When leaks occur, the defective component is replaced and or repaired and the surrounding area is cleaned.

Aquatic Harvesting strives to minimize and quickly respond to equipment malfunctions. We keep spare parts available on work sites and do not use equipment that threatens to cause pollution. Our equipment utilizes US Coast Guard approved hydraulic oil. This fluid is approved for use in environmentally sensitive areas.

Finally, we recognize and take steps to prevent the introduction of new plants. After each job our equipment is thoroughly cleaned, and all plant / animal pieces are removed and pressure washed with hot water.



MUNIQUIP, LLC

Your Source For Water & Wastewater Equipment



DATE: 5/12/26
TO: Rancho Murieta
RE: **Grundfos Paco Pumps**

QUOTE #28341

Dear Travis,

We're pleased to offer you the Grundfos PACO options for your consideration. Item 1 below is a complete pump and base, while item 2 is the wet end and motor with no base.

ITEM 1

Grundfos PACO LC 10-20709-140008-2851P

Designed for the duty condition of 267GPM at 200' TDH. In cast iron construction, 2.5" suction 2" discharge ANSI flanged, stainless steel 304 impeller, type 21S seal, tin bronze wear ring, bronze shaft sleeve, 3x230/460V 60Hz 3600rpm 20HP TEFC motor, included base, coupling and shipping included, as manufactured by **Grundfos**.

Item 1 for the price of**\$9,779.86**

ITEM 2

Grundfos PACO LC 10-20709-140008-2851P

Designed for the duty condition of 267GPM at 200' TDH. In cast iron construction, 2.5" suction 2" discharge ANSI flanged, stainless steel 304 impeller, type 21S seal, tin bronze wear ring, bronze shaft sleeve, 3x230/460V 60Hz 3600rpm 20HP TEFC motor, **does not** include base, shipping included, as manufactured by **Grundfos**.

Item 2 for the price of**\$6,677.79**

NOTES:

Lead time – 18-20 Weeks.

Sales tax and startup services are not included in the above pricing.

Shipping is included in the above pricing.

Prices exclude anchor bolts, intermediate guide rail brackets, controls, VFDs and other components not specifically included in the above details.

Quotation is valid for 30 days.

This proposal is subject to the attached MuniQuip Terms & Conditions and/or the Terms and Conditions of the individual companies MuniQuip has quoted.

Initial _____

Best Wishes,

Joshua Wyatt

Sales Engineer

2017 Opportunity Drive, Suite 4

Roseville, CA 95678

916-759-3292 cell

916-787-5641 office

916-787-5642 fax

2017 Opportunity Drive # 4, Roseville, CA 95678, (916) 787-5641 office, (916) 787-5642 fax

Grundfos Series LC - End Suction Centrifugal Pump, Close Coupled

QUOTE NUMBER / ID 1897883	UNIT TAG 001	QUANTITY 1
REPRESENTATIVE	SERVICE	DATE
ENGINEER	SUBMITTED BY	DATE
CONTRACTOR	APPROVED BY	DATE
	ORDER #	DATE



LC 20709
3530 rpm

Part Number N/A

Conditions of Service		Pump Data		Motor Data	
Flow	267.0 USgpm	Impeller Diameter	7.01 in	Motor HP	20 HP
Head	200.0 ft	Max. Imp. Dia.	7.10 in	BHP	16.93 HP
Liquid	Cold Water	Min. Imp. Dia.	5.00 in	Enclosure	TEFC
Temperature	68.00 deg F	Efficiency	79.8 %	Voltage	230/460 V
NPSHr	12.63 ft	Suction	2.5 in.	Phase	3 Phase
Viscosity	1.00 cP	Discharge	2 in.	Cycle	60
Specific Gravity	1.000 SG	PEI (CL)	0.88	Frame Size	256JMZ
		ER (CL)	12		

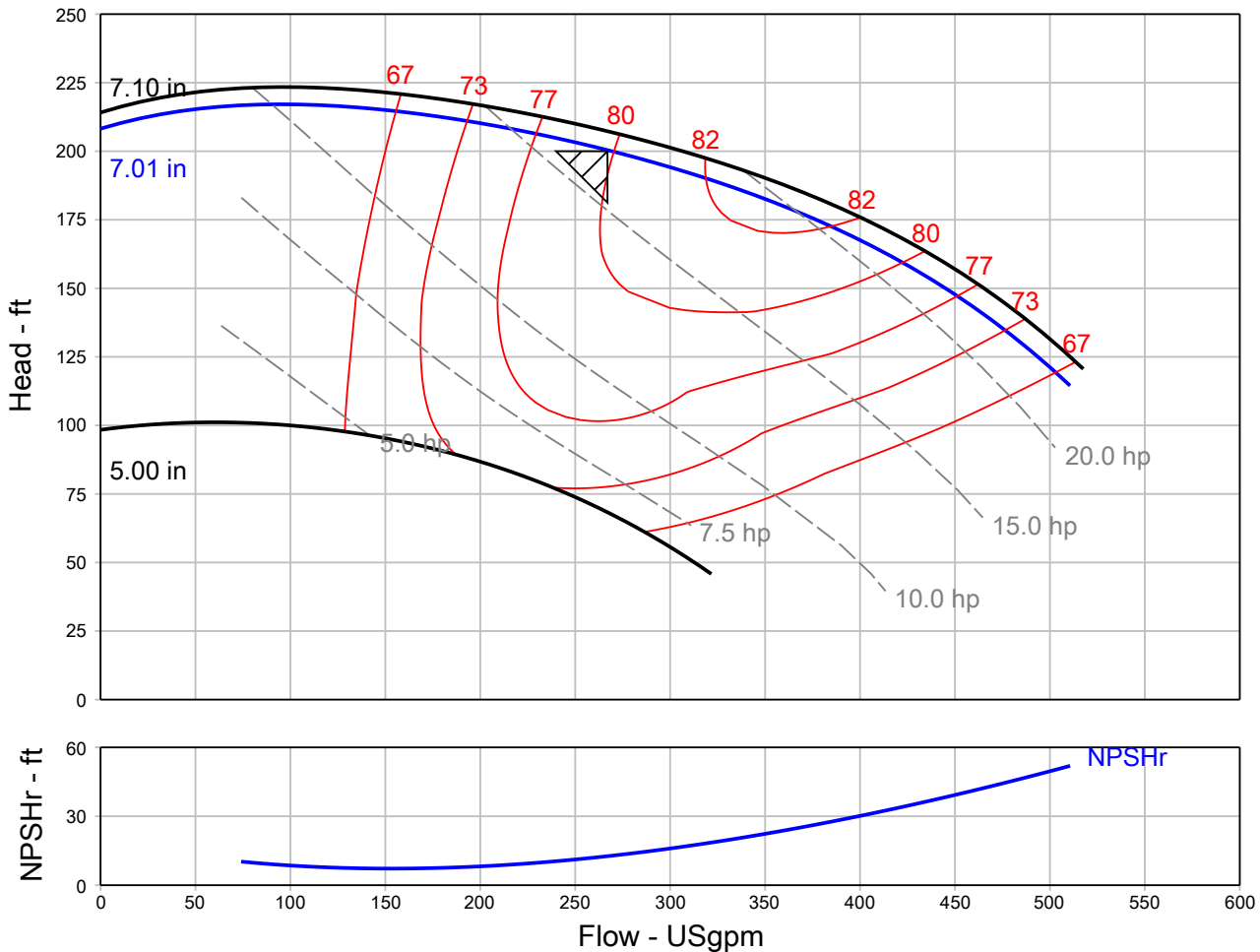

Grundfos Series LC - End Suction Centrifugal Pump, Close Coupled

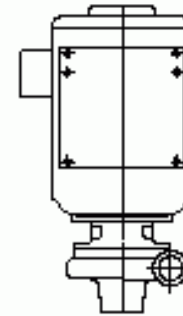

PLAN

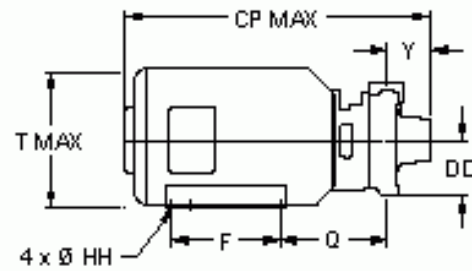

SIDE VIEW

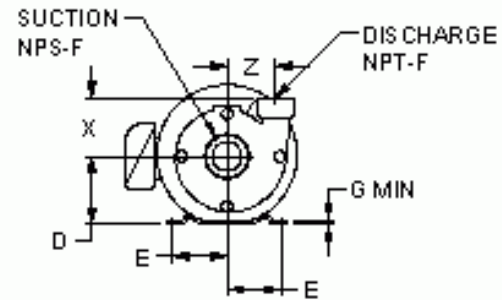

END VIEW

NOT FOR CONSTRUCTION, unless certified and referenced on order

Units	Frame	Suct	Disch	CP	D	DD	E	F	G	HH	Q	T	X	Y	Z	Weight
inches	256	2.5	2	28.00	7.50	5.13	3.75	7.50	0.63	0.44	2.88	11.50	5.38	3.94	4.50	TBD

Grundfos Series LC - End Suction Centrifugal Pump, Close Coupled

QUOTE NUMBER / ID 1897883	UNIT TAG 001	LC 20709
----------------------------------	---------------------	-----------------

MATERIALS OF CONSTRUCTION			
PART	MATERIAL	PART	MATERIAL
Rotation Options	Clockwise	Impeller Washer	S.S., AISI-303
Base/Stand Type	None	Impeller Key	Steel, AISI 1045
Connections	FPT (threaded)/ 125# ANSI	Sleeve Material	Bronze, III932, C89835 or No Sleeves
Wear Ring Type	Case Wear Ring	Wear Ring Material	Tin Bronze, ASTM B584-90500
Pump Coatings	Standard Paint	Packing Gland	Not Applicable
NSF-50 Certification	Optional	Lantern Ring	None
NSF-61 Certification	Optional	Seal Type	Type 21
Motor Drip Canopy	Optional	Seal Material	Ceramic/Carbon/Buna
Casing	Cast Iron, ASTM-A48, CL 30	O-Rings	Buna N
Motor Shaft	Steel, AISI 1045 or S.S	Seal Flush Options	No External flush
Backplate/Seal Plate	Cast Iron, ASTM-A48, CL 30	Gaskets	Vegetable Fiber
Motor Bracket	Cast Iron, ASTM-A48, CL 30	Casing Bolts	Steel, Grade 5
Impeller	Stainless Steel, AISI-304	Impeller Cap Screw	Stainless Steel, AISI-316

* All materials based on STANDARD configuration

Pump Performance Datasheet

Customer :	Quote Number / ID :	1897883
Customer ref. / PO :	Model :	20709 LC
Tag Number : 001	Stages :	1
Service :	Based on curve number :	RC9912-1-SS Rev May22
Quantity : 1	Basic model number :	-
	Date last saved :	04/17/2026 10:22 AM

Operating Conditions		Liquid	
Flow, rated	: 267.0 USgpm	Liquid type	: Cold Water
Differential head / pressure, rated (requested)	: 200.0 ft	Additional liquid description	:
Differential head / pressure, rated (actual)	: 200.4 ft	Solids diameter, max	: 0.00 in
Suction pressure, rated / max	: 0.00 / 0.00 psi.g	Solids concentration, by volume	: 0.00 %
NPSH available, rated	: Ample	Temperature, max	: 68.00 deg F
Site Supply Frequency	: 60 Hz	Fluid density, rated / max	: 1.000 / 1.000 SG
		Viscosity, rated	: 1.00 cP
		Vapor pressure, rated	: 0.34 psi.a

Performance		Material	
Speed, rated	: 3530 rpm	Material selected	: Cast iron
Impeller diameter, rated	: 7.01 in		
Impeller diameter, maximum	: 7.10 in		
Impeller diameter, minimum	: 5.00 in		
Efficiency	: 79.80 %		

Performance		Pressure Data	
NPSH required / margin required	: 12.63 / 0.00 ft	Maximum working pressure	: 93.96 psi.g
Ns (imp. eye flow) / Nss (imp. eye flow)	: 1,325 / 6,186 US Units	Maximum allowable working pressure	: 175.0 psi.g
MCSF	: 96.27 USgpm	Maximum allowable suction pressure	: 175.0 psi.g
Head, maximum, rated diameter	: 217.1 ft	Hydrostatic test pressure	: 263.0 psi.g
Head rise to shutoff	: 3.90 %		
Flow, best eff. point	: 353.2 USgpm		
Flow ratio, rated / BEP	: 75.60 %		
Diameter ratio (rated / max)	: 98.73 %		
Head ratio (rated dia / max dia)	: 96.68 %		
Cq/Ch/Ce/Cn [ANSI/HI 9.6.7-2010]	: 1.00 / 1.00 / 1.00 / 1.00 / 1.34		
Selection status	: Acceptable		

Energy Indexes		Driver & Power Data (@Max density)	
PEI (CL)	: 0.88	Motor sizing specification	: Rated power (based on duty point)
ER (CL)	: 12	Margin over specification	: 0.00 %
		Service factor	: 1.00
		Power, hydraulic	: 13.51 hp
		Rated power (based on duty point)	: 16.93 hp
		Max power (non-overloading)	: 22.74 hp
		Nameplate motor rating	: 20.00 hp / 14.91 kW

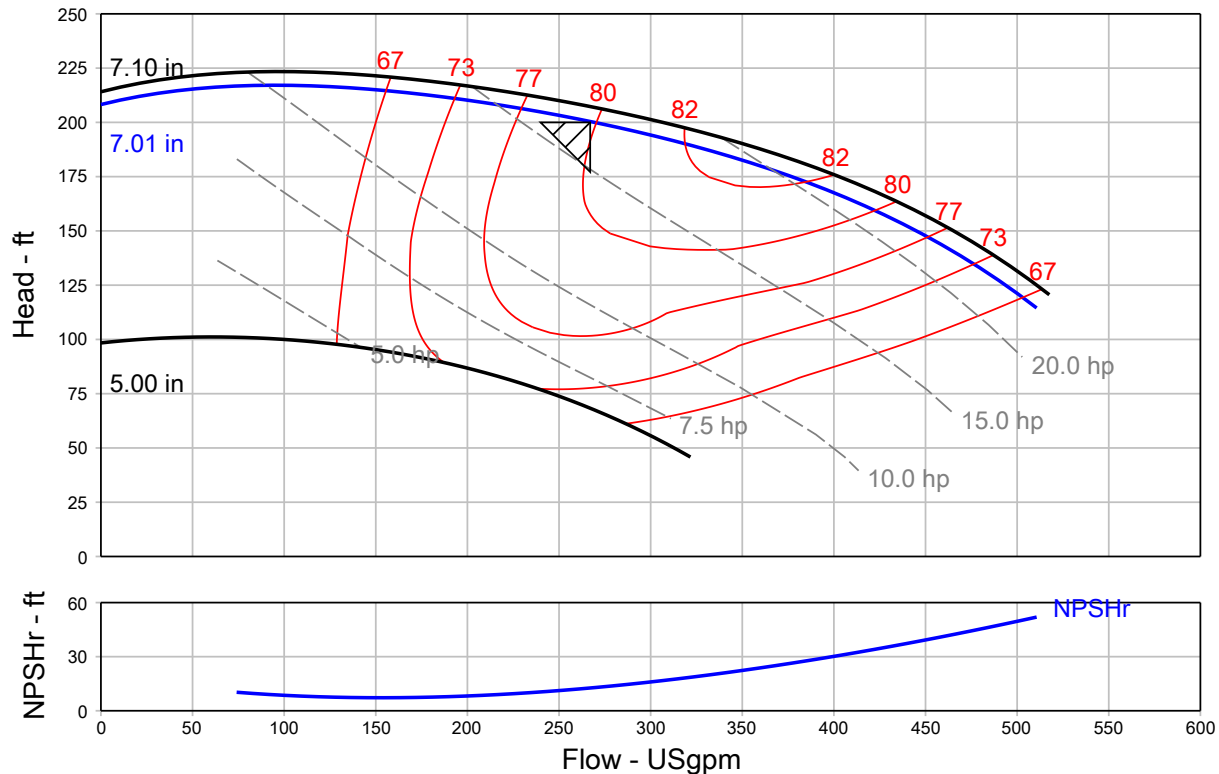

Construction Datasheet

Project name	: Default	Tag Number	: 001
Consulting engineer	:	Service	:
Customer	: MUNIQUIP INC	Model	: 20709 LC
Customer ref. / PO	:	Quantity	: 1
Quote Number / ID	: 1897883	Grundfos Partner	: MUNIQUIP INC
Date last saved	: 04/17/2026 10:22 AM	Quoted By (Sales Engineer)	: Joshua Wyatt

Construction				Motor Information	
Nozzle	Size (in.)	Nozzle Configuration	Pos'n	Manufacturer	: Baldor
Suction	2.5	NPS	End	Frame Size	: 256JM
Discharge	2	NPS	Top	Power	: 20.00 hp

Orientation / Configuration	: Horizontal	RPM	: 3600 rpm
Rotation	: Clockwise	Enclosure	: TEFC
Wear Ring Configuration	: Single - Case	Operating Power Supply	: 230/460/3/60
Discharge Elbow Size	: -	Efficiency	: Premium
Subplate	: -	Service factor	: 1.15
Sump Depth (feet)	: -	Motor Application	: General Purpose
Bearing Frame	: -	Motor Options/Accessories	: -
Bearing Frame Foot	: -	Cord Length (feet)	: -

Materials	
Case	: Cast Iron, ASTM A48 - Class 30
Motor Bracket	: Cast Iron, ASTM-A48, CL 30
Impeller	: Stainless Steel, AISI-304 (H304)
Impeller Cap Screw and Washer	: Stainless Steel, AISI-303
Impeller Key	: Stainless Steel, AISI 316
Case wear ring	: Tin Bronze, ASTM B584-90500 (B18)

Baseplate, Coupling and Guard	
Baseplate	: Cast Iron - ASTM A48 Class 30
Drip Pan	: Drip Rim
Coupling	: -
Guard	: Not Applicable

Seal & Packing Construction	
Sealing Method	: Single Seal, Type 21S
Seal Material	: Buna Carbon Ceramic SS-Spring and Hardware
Packing Gland	: -
Lantern Ring	: -
Recirculation Lines	: None

Weights (Approx.)	
Pump	: 45.00 lb
Baseplate	: -
Driver	: 267.0 lb
Estimated Shipping gross weight	: 312.0 lb

Impeller wear ring	: -
Pump Shaft	: Steel, AISI-1040
Sleeve	: Bronze, III932, C89835
Line Shaft	: -
Column	: -
Discharge Pipe	: -
Discharge Elbow	: -
Suction Elbow	: -
Subplate	: -
Hardware	: Steel, Grade 5
O Rings	: Buna N
Pump Coatings	: Standard Manufacturer's Paint



TERMS AND CONDITIONS

1. Acceptance of this Order is final only upon written approval by MuniQuip, L.L.C. ("MQ").
2. The total sale price, as set forth on the first page hereof, including all tax, is payable by Purchaser as follows: One-Hundred percent (100%) within 30 days of notice of availability for shipment by the manufacturer. Any amount not paid when due shall bear interest at the rate of 18% *per annum*. Purchaser agrees to pay reasonable attorney's fees and all collection costs incurred by MQ if payment is not timely received. All payments by Purchaser shall be made without offset or deduction.
3. All prices are FOB source shipping point. MQ is not responsible for any loss during transit. Breakage or shortage claims arising from shipments shall be made by the Purchaser directly against the carrier. Purchaser will accept shipment within five (5) days of notice of availability from MQ.
4. Purchaser understands and acknowledges that the Equipment is not manufactured by MQ, and that MQ offers no representations or warranties of any kind or nature with respect to the Equipment. **SPECIFICALLY, MQ DOES NOT OFFER ANY EXPRESS OR IMPLIED WARRANTY OF DESCRIPTION, TITLE, OR CONDITION OF LIEN OR SECURITY INTERESTS, MERCHANTABILITY, OR FITNESS FOR A PARTICULAR PURPOSE.** The only warranties with respect to the Equipment shall be those offered by the manufacturer, if any. The sole obligation of MQ shall be to assist Purchaser in connection with the presentation of any warranty claim to the Manufacturer. If applicable, MQ will assign all manufacturers' warranties to Purchaser or end user. Purchaser shall be responsible for all costs and labor for installation and start-up assistance of the Equipment.
5. MQ shall not be responsible for any loss, claim or damages resulting from any force majeure, including but not limited to strikes, accidents, unavailability of labor or materials, acts of God, weather conditions, inability of carrier to deliver, legislative, administrative, or executive law, order or requisition of any governmental entity, or any event not under the direct control of MQ. Any delay in delivery from the Manufacturer caused by a force majeure or action or inaction of the Manufacturer or carrier shall not be the responsibility of MQ.
6. In no event shall MQ be responsible for any liquidated, consequential or special damages arising from breach of this Agreement, any delay of delivery or any other cause.
7. Purchaser shall pay any sales, excise, or other government charge payable by MQ to federal, state or local authorities. Any such taxes now or hereafter imposed upon sales or shipments will be added to the purchase price. Purchaser agrees to reimburse MQ for any such tax or to provide MQ acceptable tax exemption certificates.
8. Purchaser may not cancel this Order without the prior written consent of MQ, and in any event Purchaser shall be responsible for all costs, charges and fees caused by such cancellation, including labor expended, material procured, and reasonable overhead expenses applicable thereto.

Initial _____



MUNIQUIP, LLC

Your Source For Water & Wastewater Equipment



- 9. Any failure of MQ to insist upon the performance of any term or condition of this Agreement or any prior quotations, agreements, orders, and acceptances or orders related thereto shall not be deemed to be a waiver of such term, condition, or any other right in the future.
- 10. The provisions hereof shall apply to all addendums or changes hereto although not specifically set forth therein, all of these terms and conditions being considered to be additional terms and conditions to any such addendum or change.
- 11. Purchaser agrees to inspect the Equipment immediately upon delivery. Any claim for shortages must be made to MQ within ten (10) days after shipment or shall be deemed waived. Any other claim by Purchaser, other than warranty claims against the manufacturer, shall be made within thirty (30) days after receipt of shipment, and if not made, shall be waived.
- 12. Purchaser agrees to provide and maintain adequate insurance against loss of or damage to the Equipment until the purchase price to MQ has been fully paid. Any loss or damage to the Equipment after transfer of possession shall not relieve the Purchaser from obligations under this Agreement.
- 13. This Agreement represents the final and complete understanding of the parties with respect to all terms and conditions of the sale of Equipment as contemplated hereby, and there are no other representations, promises or agreements, whether written or oral, made in connection herewith. Purchaser specifically understands and acknowledges that no agent, employee or representative of MQ has the authority to or has made any other representation, promise or agreement except as specifically set forth in this Agreement. No amendment to this Agreement shall be effective unless it is in writing and executed by both parties.
- 14. This Agreement shall be construed under the laws of the State of California, and any action arising hereunder shall be commenced in that state.

Customer Signature: _____

Print Name: _____

Title: _____

Company Name: _____

Date: _____

Purchase Order #: _____

RESOLUTION R2026-06

A RESOLUTION OF THE BOARD OF DIRECTORS OF THE RANCHO MURIETA COMMUNITY SERVICES DISTRICT, CALIFORNIA, CALLING THE GENERAL DISTRICT ELECTION AND REQUESTING THE BOARD OF SUPERVISORS OF THE COUNTY OF SACRAMENTO TO CONSOLIDATE THE DISTRICT GENERAL ELECTION TO BE HELD ON NOVEMBER 3, 2026, WITH THE STATEWIDE GENERAL ELECTION ON THE SAME DATE

WHEREAS, an election will be held within the Rancho Murieta Community Services District (“District”) on November 3, 2026, for the purpose of electing three (3) members of the Board of Directors who will serve a full term of four (4) years and one (1) member of the Board of Directors who will serve for a remaining term of two (2) years; and

WHEREAS, a statewide general election will be held within the County of Sacramento (the “County”) on the same day; and

WHEREAS, Elections Code Section 10403 requires jurisdictions to file with the Board of Supervisors, and a copy with the Registrar of Voters, a resolution requesting consolidation with a statewide election.

NOW, THEREFORE, BE IT RESOLVED by the Board of Directors of the Rancho Murieta Community Services District as follows:

SECTION 1. Pursuant to the requirements of the laws of the State of California relating to special districts, the elective offices of the District to be filled at the next General District Election shall be as follows:

- (a) A member of the Board of Directors for a full term of four (4) years.
- (b) A member of the Board of Directors for a full term of four (4) years.
- (c) A member of the Board of Directors for a full term of four (4) years.
- (d) A member of the Board of Directors for the remaining term of two (2) years, which expires in November 2028.

SECTION 2. Pursuant to Elections Code Sections 10400 and 10403, the Rancho Murieta Community Services District requests the Board of Supervisors of Sacramento County to consolidate the regularly scheduled General District Election with the statewide election to be held on November 3, 2026.

SECTION 3. Pursuant to Elections Code Section 13307(a), the candidate is to pay for the publication of the candidate’s statement. The limitation on the number of words that a candidate may use in his or her candidate’s statement is 200 words.

SECTION 4. The Rancho Murieta Community Services District requests the Board of Supervisors of Sacramento County to permit the Registrar of Voters to perform any and all services necessary for conducting the election.

SECTION 5. The Rancho Murieta Community Services District recognizes that additional costs will be incurred by the County of Sacramento by reason of this consolidation and agrees to reimburse the County of Sacramento for actual costs accrued in conducting the consolidated election, such costs to be calculated by the method set forth in the County’s current Election Cost Allocation Procedures.

PASSED AND ADOPTED on June 17, 2026, by the following roll call vote:

AYES:
NOES:
ABSENT:
ABSTAIN:

John Merchant, President of the Board
Rancho Murieta Community Services District

(Seal)

ATTEST:

Dyanne Fleet, Interim District Secretary

Rancho Murieta Community Services District

July

Board/Committee Meeting Schedule

July 1, 2026

Improvements 8:00 a.m.

July 2, 2026

Security 9:00 a.m.

Communications 10:00 a.m.

July 7, 2026

Personnel 9:00 a.m.

July 9, 2026

Finance 10:00 a.m.

July 15, 2026

Regular Board Meeting - Open Session 5:00 p.m.



All meetings will be held in person at the District Office: 15160 Jackson Rd.

MEMORANDUM

Date: June 12, 2026
To: Board of Directors
From: Amelia Wilder, Interim General Manager
Re: General Manager's Report

BOARD ELECTION: A HISTORIC TURNING POINT

This November, registered voters will elect four new Board Members. Coupled with the upcoming hire of a new General Manager and Director of Operations, this election marks a major turning point for our District. We encourage any resident interested in local government to step forward—no prior political experience is required, just a desire to shape our community's future, and being a registered voter in Rancho Murieta.

- Commitment: Attendance at one regular Board meeting per month, with optional participation on Board committees.
- Filing Period: July 13, 2026, through August 7, 2026.
- How to Run: Candidate filing paperwork may be obtained from the Sacramento County Voter Registration and Elections Office, located at 7000 65th Street, Suite A, Sacramento, California

EXECUTIVE RECRUITMENT

Our recruitment partner, Peckham McKenney, reports strong interest in the General Manager position. Candidate interviews are scheduled to begin later this month. We hope to have a new General Manager identified in July.

DEVELOPMENT & INFRASTRUCTURE

Administrative focus remains heavily on unwinding Financial Service Agreements (FSAs), with resolutions anticipated shortly.

HR PROGRESS

Comprehensive updates to the Personnel Manual are nearly finished. The final draft, incorporating updated employee policies, will be presented for Board approval in July.

Protecting Our Reservoirs From Invasive Species

Security Supervisor Branden Arino is partnering with the California Department of Fish & Wildlife to combat invasive mussels. Once established, these species form colonies that are nearly impossible to remove. They pose a severe threat by clogging water treatment systems and pipelines.

Prevention through watercraft inspection is our only line of defense. At the end of June, Mr. Bohannon and three security department members will complete official certification training. Following this training, security personnel will inspect all watercraft entering the gates.

We will continue working with the [CA Department of Fish & Wildlife](#) to educate residents about these hazards and protect our water supply.

SECURITY MEETING WITH RMA

Director Merchant and I held an introductory meeting with the Rancho Murieta Association (RMA) to discuss the potential transfer of the Security Department to their oversight. This initial discussion was strictly preliminary. Further updates on this topic will be provided as information becomes available.

MEMORANDUM

Date: June 17, 2026

To: Board of Directors

From: Branden Arino, Security Supervisor

Subject: Security Department Update – May 2026

Operations Update

The Security Department continues to prioritize staffing stability, operational readiness, and proactive community engagement. Key updates are as follows:

- All full-time Security Department positions are currently filled.
- **Current staffing levels:**
 - 7 Full-Time Gate Officers
 - 6 Part-Time Gate Officers
 - 4 Full-Time Patrol Officers
 - 17 Total Employees (including 6 probationary employees)
- Coordinated North Gate repairs with A&D Gate for the damage caused by the collision on May 17th total estimated cost to be \$22,525.62 GSMR Insurance was notified.
- Fish & Wildlife has connected the Department with a field scientist who has been in communications about possibly implementing invasive species prevention programs within Rancho Murieta to which when successful can open up opportunities for Government Grants. Fish & Wildlife has mentioned other communities like Lake Wildwood and Lake of the Pines have already done these programs.
- Vehicle Unit 53 rear passenger tire had substantial air leak and was repaired.

Rancho Murieta Association (RMA) Coordination

The Security Department continues to collaborate closely with Rancho Murieta Association (RMA) leadership to strengthen rule enforcement, compliance coordination, and overall community safety. Key efforts include:

- Ongoing enforcement of non-architectural RMA rules in coordination with RMA Compliance (see Violation Summary Report).
- Weekly speed enforcement operations conducted in accordance with RMA guidelines.
- Continued attendance and active participation in RMA Compliance Committee meetings.
- RMA Rule enforcement has been picked up substantially by Security Patrol Officers, with a focus on safety and overnight parking concerns.

Gate Entries by Type

5/1/2026 - 5/31/2026

Pass Type	Guest Count North Gate	Guest Count South Gate	Count by Pass Type
Construction	215	190	405
Guest	4,444	2,856	7,300
Real Estate	41	88	129
Vendor	2,280	1,477	3,757
Country Club (x)	234	4	238
Special Event	162	60	222
TOTALS	7,376	4,675	12,051

Prior Month Totals:

7,519	4,338	11,857
--------------	--------------	---------------

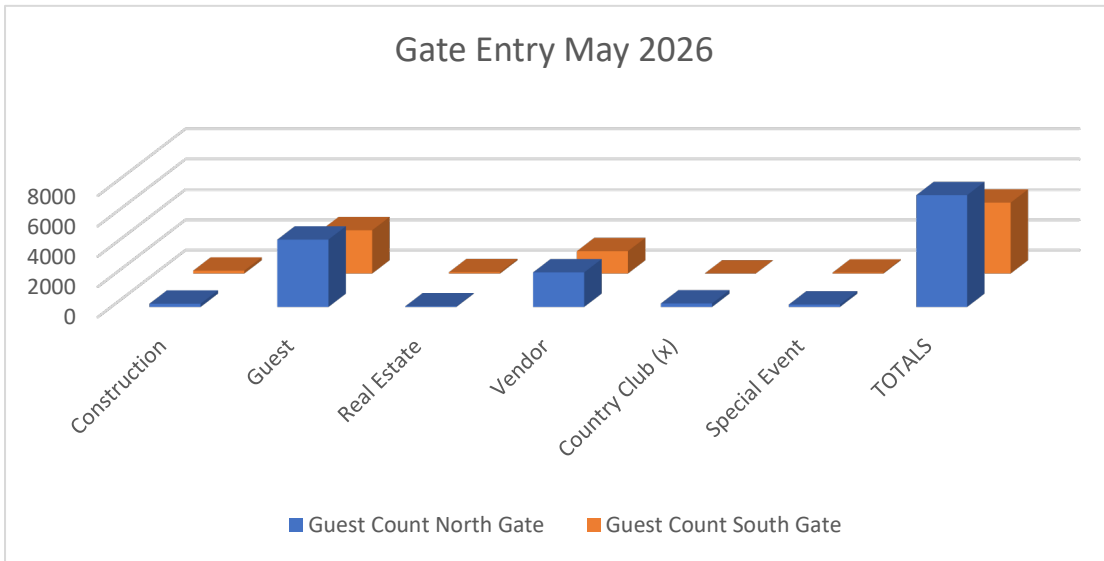

Rancho Murieta Association
Violation Item Summary Report -- 2026
(This report includes RMA & CSD issued violations)

Violation Item Summary Report	Jan		Feb		March		April		May		June		July		August		September		October		November		December		Totals			
	CSD	RMA	CSD	RMA	CSD	RMA	CSD	RMA	CSD	RMA	CSD	RMA	CSD	RMA	CSD	RMA	CSD	RMA	CSD	RMA	CSD	RMA	CSD	RMA	CSD	RMA		
Motor vehicle violations:																												
Carrying Passengers					1	0																				1	0	
Motorcycle																										0	0	
No drivers license									0	1																0	1	
Speeding	0	107	0	89	1	120	0	166	2	165															3	647		
Speeding - twice speed limit					0	2	0	1																		0	3	
Stop signs	1	17	0	26	2	23	1	24	3	14															7	104		
Bus stop signs																										0	0	
Use of streets					0	1																				0	1	
Parking:																												
Driveway parking	0	2																								0	2	
Guest parking																										0	0	
Overnight street parking	1	3	2	0	6	0	12	0	5	0															26	3		
Unauthorized Vehicle (24 hr pass)									0	1																0	1	
No Parking Areas	1	0	1	0	1	0	2	0	5	0																10	0	
Accumulation/dumping of debris																										0	0	
Boat Usage																										0	0	
Barbeques, open fires, bonfires																										0	0	
Carrying passengers/overloaded cart																										0	0	
Chickens																										0	0	
Commercial vehicle lettering																										0	0	
Construction overnight parking																										0	0	
Discharge of firearm																										0	0	
Dwelling exterior alterations																										0	0	
Failure to identify																										0	0	
Golf Cart Decals																										0	0	
Guest w/o resident in comm areas																										0	0	
Home business activities																										0	0	
Interference-Identification RMA/RMCS																										0	0	
Noxious activities																										0	0	
Open garage doors	0	1	0	1																						0	2	
Park hours / curfew	2	0	1	0	1	0	4	0	5	0																13	0	
Pets - All Violations							0	2	0	1																0	3	
Property maintenance	0	5	0	2	0	6	0	5	0	11																0	29	
Sign rules																										0	0	
Sports equip/trampoline/basketball																										0	0	
Storage of building materials																										0	0	
Stored vehicles	0	4	1	0	0	2	0	3																		1	9	
Trash containers																										0	0	
Unlawful Activity																										0	0	
Use of common areas & facilities																										0	0	
Use of Fireworks																										0	0	
Vandalism																										0	0	
Vehicle repair or maintenance																										0	0	
Working days & hours																										0	0	
Total Violations	5	139	5	118	12	154	19	201	20	193	0	0	0	0	0	0	0	0	0	0	0	0	0	0	0	0	61	805
Citations written by RMCS		5		5		12		19		20				0		0		0		0		0					61	
Citations written by RMA	139		118		154		201		193					0		0		0		0		0					805	
Total Violations	144		123		166		220		213		0	0	0	0	0	0	0	0	0	0	0	0	0	0	0	61	866	



Rancho Murieta CSD Security

15160 Jackson Rd
Rancho Murieta, CA 95662

Cases - Breakdown by Type

ABANDONED DISABLED VEH	2
ALARM	8
ANIMAL COMPLAINT	7
ASSIST OTHER AGENCY	3
CITATION	33
DISTURBANCE	1
ESCORT	4
EXTRA PATROL	132
FOLLOW UP	2
JUVENILE DELIQUENCY	2
LOST/FOUND PROPERTY	6
MEDICAL AID	1
MISCELLANEOUS	10
MISSING PERSON	1
PATROL DETAIL	1
REFUSED ENTRY	54
RESIDENT COMPLAINT	19
RMA RULE VIOLATION	7
SPEEDING COMPLAINT	5
STOLEN/MISSING VEHICLE	1
SUSPICIOUS ACTIVITY	1
SUSPICIOUS PERSON	5
SUSPICIOUS VEHICLE	1
TRAFFIC ENFORCEMENT	5

TRESPASSING	12
VANDALISM	2
VEHICLE ACCIDENT	6
WATER LEAK	7
WELFARE CHECK	1
Total	339





Rancho Murieta Community Services District

15160 Jackson Road • P.O. Box 1050 Rancho Murieta, CA 95683 • 916-354-3700 • Fax 916-354-2082

Visit our website-www.rmcsl.com

May 2026 Incidents of Note

On May 17th, 2026, at approximately 2312 hours, Security responded to a major traffic collision at the North Gate resident lanes. An inbound vehicle traveling at a high rate of speed crossed from the resident lane into the guest lane, struck the median and gate infrastructure, became airborne, and overturned after colliding with the gatehouse entry equipment.

Upon arrival, Security personnel observed bystanders attempting to assist the trapped driver. Sac Metro Fire, ambulance personnel, and California Highway Patrol responded to the scene. The driver was extricated and transported to a local hospital with injuries.

The collision resulted in extensive damage to North Gate infrastructure, including a destroyed gate arm, destroyed BAI Barcode Scanner, broken window, and structural damage to the gatehouse area. Traffic control measures were implemented until the scene was cleared. CHP is conducting a collision investigation.

Serving the Community for over 30 years

Board of Directors: John Merchant, President • , Linda Butler, Vice-President • Randy Jenco • Tim Maybee • Bill Gere

Information Technology Manager's Report to the Board of Directors

June 17, 2026

PROJECT UPDATES

Conference Bar and Teams Rooms Installation

Purchased and installed a conference bar in the Big Conference Room and subscribed RMCS D to Microsoft Teams Rooms for a much-improved conference experience. Training for staff will be provided.

New Board Room Conference System

We are currently investigating technology and vendors for a new Board Room conference system that will include video with closed captioning functionality.

New Computers and Windows 11 Nearing Completion

The last of the computer replacements and upgrades to Windows 11 are occurring now and are expected to be completed within the next several weeks as time allows.

Cybersecurity Training – In Progress

Cybersecurity training is continuing for all staff. New lessons roll out at the beginning of each month. Staff are expected to complete the training on their own schedule over the course of the month. Random phishing tests will be administered.

Wi-Fi Access Point Update – In Progress

District Wi-Fi access points are aging out of service and being updated to the latest Wi-Fi 7 technology. Boardroom and server room units have been updated. Work will continue on this over the next several months.

Network Failover for Greenfield ISP using StarLink – In progress

We are researching the implementation of a secondary failover network in the Admin building to keep our Internet connection active when Greenfield service goes down. This will prevent the gates from going offline and other service interruptions during an outage. The same system could also be installed at the water plant to keep it online during outages.

Surveillance Systems Upgrades

The first phase of this project is complete. Hardware in the gate shacks has been updated, and all systems are now running Windows 11. The second phase of the project is currently on hold, awaiting approval and allocation of funds after the audits are complete.

Replacement of Inter-Building Network Communication Hardware

Hardware to replace the aging NanoBeam and AirFiber systems that provide network connectivity between the Administration and WWTP buildings is being procured now and will be installed in the coming two months.

Updating, Inventorying and Disposal of Equipment

Equipment inventories are being updated, and support agreements are being refreshed. Equipment that has aged out of service is being sent to e-waste.

Task	Priority	Finish Date
IN PROGRESS:		
New Desktop and Laptop Rollouts. Windows 11 update	High	Q2 2026
Cybersecurity Training for Staff	High	Beginning Apr. 1
Network Failover for Greenfield ISP	High	June 2026
Purchase new surveillance hardware and update systems	High	In progress, TBD
Replacement of NanoBeam and AirFiber systems	High	June 2026
Hardware and software support for all RMCS staff	High	Ongoing
PCI Compliancy Audit for credit card processing	High	Q2, 2026
Ensure compliance with GSRMA computer standards	High	Ongoing
Disaster Recovery Plan creation	High	Q2, 2026
Business Continuity Plan creation	High	Q2, 2026
Cybersecurity Incident Response Plan creation	High	TBD
Documentation of the RMCS computing environment. Network, application and database mapping	High	TBD
Update the IT asset inventory database	High	TBD
Update of the web site to meet new ADA and DOJ requirements	Medium	TBD
Evaluate moving the RMCS computing environment to the Microsoft Azure cloud. Implement if desired	Medium	TBD
Update the on-premises virtualization server	Medium	TBD

COMPLETED:		
Conference Bar and Teams Rooms Installation	High	Completed
VAB-1 Network Installation for SCADA	High	Completed
Access Point for boardroom upgraded	High	Completed
Power improvements to server closet	High	Completed
GSRMA Cybersecurity Audit Questionnaire	High	Completed
CodeRED to HQE SiRcom Conversion	High	Completed
Update all mobile phones to iPhones	High	Completed
Draft RMCS D Internet Security Policy Created	High	Completed
Reconstruction of MFP/Copier/Scanner networking and user authentication	High	Completed
Implementation of Mosyle MDM for iPhone Management	High	Completed
SCADA Networking Integration	High	Completed
Credit Card Kiosk Installation	High	Completed 12/10/2025

Chief Plant Operator - Staff Report

Date: June 17, 2026

To: Board of Directors

From: Travis Bohannon, Chief Plant Operator

Subject: June 2026 Operations Report

WATER:

Water Treatment Facility

April 2026 Drinking Water Production Data (in gallons)

	Plant 1	Plant 2
<u>Totals</u>	31,446,000	16,400,333

Water Consumption

As of May 31, 2026, the total potable water production for 2026 is 120.832 million gallons or 517.84 acre-ft.

Both plants are currently in operation. We are currently producing about 2.3 MGD to meet daily demand.

Raw Water Storage & Delivery

Granlees Pump Station: Total water pumped from Granlees this pumping season as of May 31, is 655.97 MG or 2013.8 AF. Pumping season has ended and all 3 lakes were filled to capacity this year. **Hooray!!!!!!**

Table 1. Current water and wastewater storage as of May 31, 2026

	acre-ft	acre-ft full	MGal	MG at Full	%full
Clementia Storage	766.01	690.9	249.5	211.7	118%
Chesbro Storage	1022.7	948.8	333.2	309.1	108%
Calero Storage	2257.9	2069.0	735.7	674.1	109%
Total Raw Water Available for Potable Treatment	3280.6	3017.8	1068.9	983.2	109%
Total of all Raw Water Reservoirs	4046.6	3667.7	1318.4	1194.9	110%
Wastewater Storage Reservoir available for production	604.5	781.4	196.9	254.6	77.3%

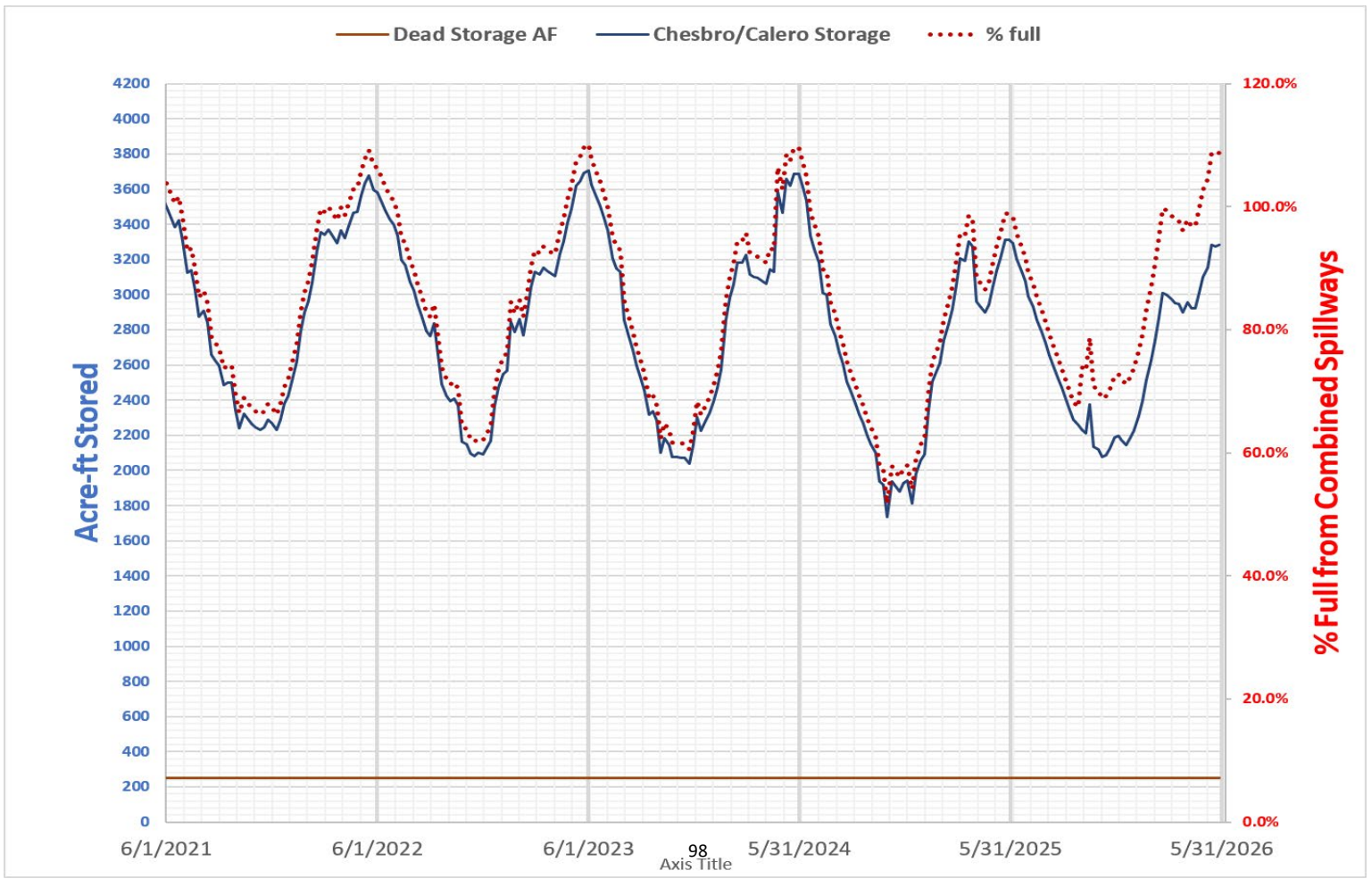
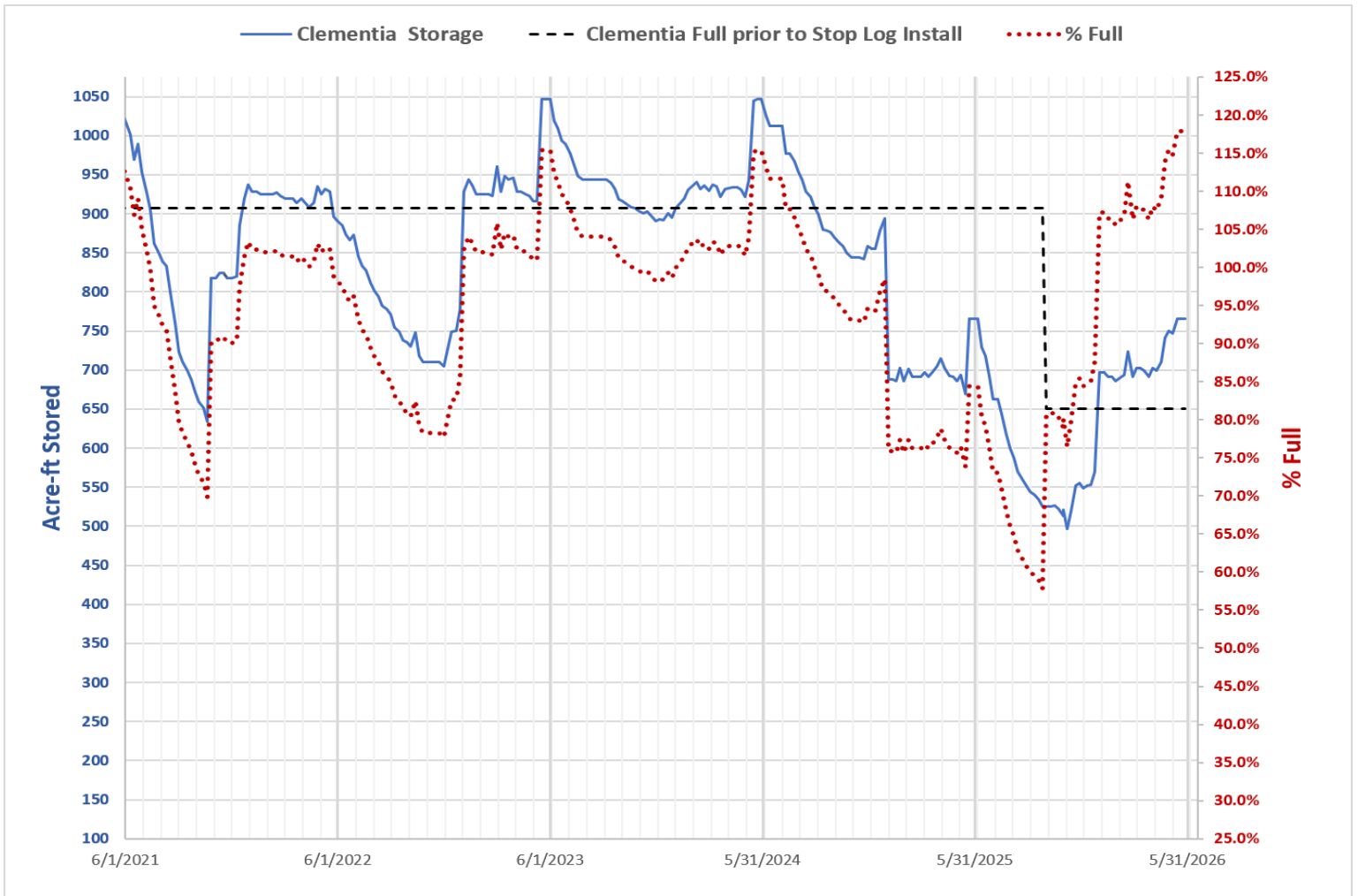

Cosumnes Flow vs. Pumped Flow to Calero FY 25-26

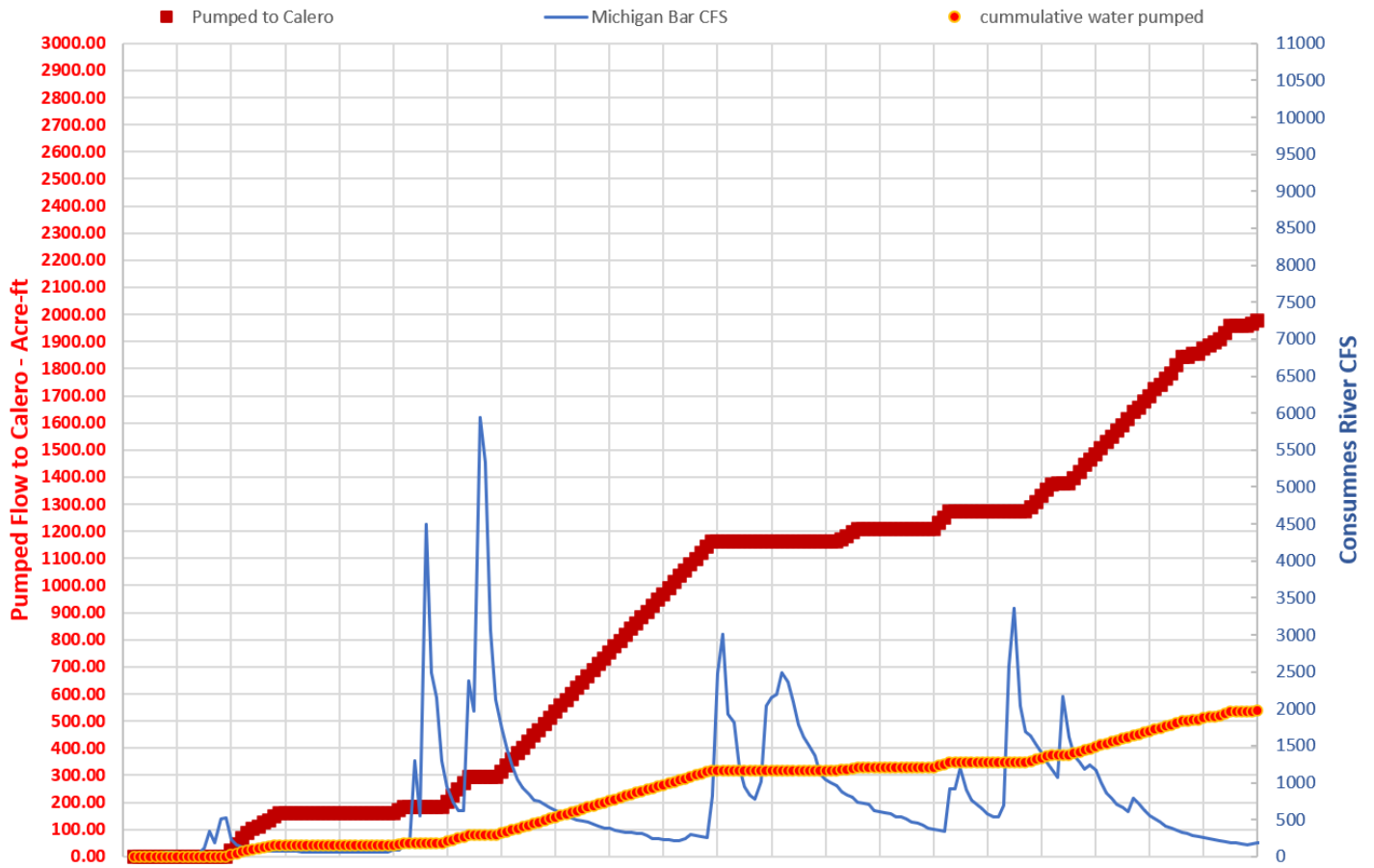

FY 25-26 Capital Improvement Plan Annual Tracker

Project Description	Budgeted Amount of Project	Total Current Cost of Project	Project Status
Water Projects			
SCADA Server Replacement	\$252,000.00	\$252,000.00	100.00%
Totals	\$252,000.00	\$252,000.00	100.00%
Waste Water Projects			
WWRP Hypochlorite Conversion	\$2,402,558.00	\$2,382,558.00	99.17%
Totals	\$2,402,558.00	\$2,382,558.00	99.17%

WASTEWATER:

Wastewater Facility

The wastewater facility is now online and producing reclaim water for the golf course. We are currently producing about 1.6 MGD. The average daily inflow to the plant for the month of May 2026 was .418 MGD.

UTILITY REPORT:

Utility Report for May 2026									
	Reported Issues	Water Leak or Sewer Overflows	Hydrants and Blow Offs Flushed	Valve Exercised	Repair or Replacement	New Installs	District Responsibility	Homeowner Responsibility	Notes
Water Distribution	50	3	7	6	2 new hydrants	5 new meters	5	4	
Meters	36				36 meter and endpoints				
Sewer Collections	1								
Drainage					Cut zone 3-b-d basin 5				Hole 14 completed
Misc., USA, Work Orders	21								

Current Projects:

Equestrian Culvert Repair: The project has been awarded to M3 Construction and is projected to start July 1st and is projected to take a month to complete.

Hole 14 Culvert Repair: This project is completed.

Clementia Spillway Culvert Repair: This project is being done in-house by the utility staff. This project is projected to start in the middle of June.

Development Updates on Number of Connections The number of water connections is 2938.

Riverview-140 total lots

Residences East and West- 198 total lots.

2025 Consumer Confidence Report



Rancho Murieta Community Services District

The Consumer Confidence Report

Rancho Murieta Community Services District (District), along with all California water retailers, is required by law to inform customers about the quality of their drinking water. The results of the district's testing and monitoring for the calendar year 2025 are reported in this newsletter.

2025 Testing Results

Measurements reported in this Consumer Confidence Report (CCR) were collected in the calendar year 2025 (unless otherwise noted). In accordance with federal regulations, data is from the most recent tests. We are allowed to monitor for some contaminants less than once per year because concentrations of these contaminants do not change frequently. The exception is that potable water production is continuously monitored to meet turbidity, pH, and disinfection residual requirements. We periodically test for all required contaminants including pesticides, metals, bacteria, and radioactive substances.

Additional references are on the Division of Drinking Water Program website at: http://www.waterboards.ca.gov/drinking_water/certlic/drinkingwater/Regulations.shtml

About Our Water Supply

Rancho Murieta's water source is the Cosumnes River, pumped up to our storage reservoirs. Because of its pristine nature, the Cosumnes River is considered low risk for many regulated contaminants, either man-induced or naturally occurring. During winter months, water from the river is pumped into the District's Calero, Chesbro, and Clementia Reservoirs for storage. Water for potable production is gravity fed or siphoned into Chesbro Reservoir from Calero Reservoir as needed for drinking water production. All water is treated at the district's water treatment facilities, below Chesbro Reservoir, fed via gravity. The treatment processes consist of either ultrafiltration through membranes or of aeration, screening, coagulation, flocculation, sedimentation, filtration through anthracite and sand filter beds, and disinfection with chlorination. Chlorine is added to drinking water as a disinfectant to kill bacteria and other disease-causing micro-organisms and is also added to provide continuous disinfection through the distribution system. Treated water is then stored in one (1) of the two (2) above ground tanks before distribution.

Source Water Assessment

An assessment of the Cosumnes River as the community's surface water source was completed in 2021. The river is most vulnerable to historic mining operations. Water pumped from the river is stored in Calero, Chesbro and Clementia Reservoirs, with Clementia Reservoir being utilized only as a recreational and raw water source. A copy of the assessment is available for public review on the District website or at the Administration Building upon request.

About Your Drinking Water

Drinking water, including bottled water, may reasonably be expected to contain at least small amounts of some contaminants. The presence of contaminants does not necessarily indicate that the water poses a health risk. More information about contaminants and potential health effects can be obtained by calling the U.S. Environmental Protection Agency's **Safe Drinking Water Hotline: 1-800-426-4791**.



Note to Sensitive Populations

Some people may be more vulnerable to contaminants in drinking water than the general population. Immuno-compromised people, such as persons with cancer undergoing chemotherapy, persons who have undergone organ transplants, people with HIV/AIDS or other immune system disorders, and some elderly people and infants, can be particularly at risk for infections. These people should seek advice about drinking water from their health care providers. USEPA/Centers for Disease Control (CDC) guidelines on appropriate means to lessen the risk of infection by Cryptosporidium and other microbial contaminants are available from the Safe Drinking Water Hotline at 1-800-426-4791.

Educational Information

The sources of drinking water (both tap water and bottled water) include rivers, lakes, streams, ponds, reservoirs, springs, and wells. As water travels over the surface of the land or through the ground, it dissolves naturally occurring minerals and, in some cases, radioactive material, and can pick up substances resulting from the presence of animals or from human activity.

Contaminants that may be present in source water include:

- ❖ *Microbial contaminants, such as viruses and bacteria that may come from sewage treatment plants, septic systems, agricultural livestock operations, and wildlife.*
- ❖ *Inorganic contaminants, such as salts and metals, can be naturally occurring or result from urban storm water runoff, industrial or domestic wastewater discharges, oil, and gas production, mining, or farming.*
- ❖ *Pesticides and herbicides may come from a variety of sources, such as agriculture, urban storm water runoff, and residential uses.*

In order to ensure that tap water is safe to drink, the U.S. Environmental Protection Agency (USEPA) and the California State Water Board (State Board) prescribe regulations that limit the amount of certain contaminants in water provided by public water systems. State Board regulations also established limits for contaminants in bottled water that provide the same protection for public health.

Units of Measurement & Terms	Definition
MG/L	Milligrams per liter or part per million (ppm).
MCL: Maximum Contaminant Level	The highest level of a contaminant that is allowed in drinking water. Primary MCLs are set as close to the PHGs (or MCLGs) as is economically and technologically feasible. Secondary MCLs are set to protect the odor, taste, and appearance of drinking water.
MRDL: Maximum Residual Disinfectant Goal	The highest level of a disinfectant allowed in drinking water. There is convincing evidence that addition of a disinfectant is necessary for control of microbial contaminants.
NTU: Nephelometric Turbidity Units	A measure of the cloudiness of water. Turbidity is monitored because it is a good indicator of water quality. High turbidity can hinder the effectiveness of disinfectants.
TT: Treatment Technique	A required process intended to reduce the level of contaminant in drinking water.
PHG: Public Health Goal	The level of contaminant in drinking water below which there is no known or expected risk to health. PHGs are set by the California Environmental Protection Agency.
MCLG: Maximum Contaminant Level Goal	The level of contaminant in drinking water below which there is no known or expected risk to health. MCLGs are set by the U.S. Environmental Protection Agency.

2025 TABLE OF DETECTED CONSTITUENTS				
CONSTITUENT	MAJOR SOURCES	PHG (MCLG) IN MG/L	MCL (MRDL) IN MG/L	RESULTS IN MG/L
DETECTED PRIMARY DRINKING WATER CONSTITUENTS REGULATED TO PROTECT YOUR HEALTH				
LEAD AND COPPER, 20 SITES (2025 RESULTS)	Internal corrosion of household plumbing and natural deposits	0.0002 lead 0.3 copper	0.05 lead, 0.015 RAL 1.0 copper, 1.3 RAL	90 th % result = 0 90 th % result = 0.31
BACTERIA-COLIFORM (TOTAL COLIFORM RULE)	Naturally present in the environment	(0)	<5%	ND
TOTAL TRIHALOMETHANES	Disinfection byproduct	N/A	0.080	0.055 av. (0.048-0.066) <i>range</i>
TOTAL HALOACETIC ACIDS	Disinfection byproduct	N/A	0.060	0.041 av. (0.038-0.047) <i>range</i>
TOTAL ORGANIC CARBON **	Various natural and man-made sources	N/A	**TT % removal	1.7 (0.6-4.1) <i>range</i>
CHLORINE	Drinking water disinfectant added for treatment	<4	4	0.77 (0.74-0.80) <i>range</i>
TURBIDITY	Suspended matter present in water that creates cloudiness; soil runoff	None	*TT = 1 NTU; 95% samples ≤0.3 NTU	0.037 NTU average (0.025-0.387) <i>range</i>
DETECTED SECONDARY DRINKING WATER CONSTITUENTS REGULATED FOR AESTHETIC QUALITIES				
SPECIFIC CONDUCTANCE (EC) UMHOS	Substances that form ions in water	N/A	1,600	94
ALKALINITY	Runoff or leaching of natural deposits	N/A	None established	45
SULFATE	Runoff or leaching of natural deposits	N/A	250	2.8
TOTAL DISSOLVED SOLIDS (TDS)	Runoff or leaching of natural deposits	N/A	1,000	62
CHLORIDE	Runoff or leaching of natural deposits	N/A	250	2.3
MANGANESE (RAW WATER)	Runoff or leaching of natural deposits	N/A	0.05	0.050 (ND-0.130) RANGE
IRON	Runoff or leaching of natural deposits	N/A	0.30	ND
DETECTED UNREGULATED DRINKING WATER CONSTITUENTS				
HARDNESS	Runoff or leaching of natural deposits	N/A	None established	36
SODIUM	Runoff or leaching of natural deposits	N/A	500	4.2
CALCIUM	Runoff or leaching of natural deposits	N/A	None established	8.1
MAGNESIUM	Runoff or leaching of natural deposits	N/A	None established	3.7

* Turbidity, measured in NTU, is a measure of the clarity of the water. It has no health effects. It is monitored because it is a good indicator of the effectiveness of our filtration system. High turbidity may hinder the effectiveness of disinfectants and may indicate the presence of disease-causing organisms.

** Total Organic Carbon (TOC) has no health effects; however, TOC provides a medium for the formation of disinfection byproducts. These byproducts include Trihalomethanes (THMs) and haloacetic acids (HAAs). If formed, drinking water containing these byproducts in excess of MCL may lead to adverse health effects, liver or kidney problems, or nervous system effects and may lead to an increased risk of getting cancer.

Have Questions?

For a complete list of constituents tested or to request additional copies of this Report or previous reports, please contact the Director of Operations at 916-354-3700. This Consumer Confidence Report was made available on our website at www.rmcsd.com on or before July 1, 2025.

The information provided in this water quality report is required by law to be available to every water user. **Property owners, please share this information with your tenants.**

This report contains important information about your drinking water. Translate it or speak with someone who understands it.

Este informe contiene información muy importante sobre su agua potable. Tradúzcalo o hable con alguien que lo entienda bien.

Source Water Protection Tips:

- Eliminate excess use of lawn and garden fertilizers & pesticides
- Dispose of chemicals properly - Pick up & dispose of pet waste

Water Conservation Rebates Available
 See <http://www.rmcsd.com>
 or call 354-3700 for more information
 subject to availability

June 2, 2026

Travis Bohannon
Chief Plant Operator
Rancho Murieta Community Services District
P.O. Box 1050
Rancho Murieta, CA 95683
916.870.5368
tbohannon@rmcsd.com

Proposal for Cosumnes River Watershed Sanitary Survey Update

Dear Travis:

We are pleased to provide you with this proposal to provide professional services to prepare the 5-year update to the Cosumnes River Watershed Sanitary Survey (WSS). The WSS will cover the watershed associated with Rancho Murieta Community Services District's (District) water treatment plants.

Project Description

The objectives of this watershed sanitary survey include:

- Meet the State Water Resources Control Board, Division of Drinking Water (DDW), Surface Water Treatment regulatory requirements
- Assess conditions in the watershed that have the potential to impact raw water quality at the surface water treatment plants
- Analyze the past 5 years of raw and treated water quality data to determine the treatment required to meet current and future drinking water regulations
- Identify watershed management practices that have the potential to reduce contaminants in the watershed

Scope of Work

The following is a detailed description of the tasks to be performed for this project:

Task 1 – Review Prior 2021 WSS and Regulatory Compliance

Verdantas will review the December 2021 WSS to identify any compliance gaps with DDW requirements and AWWA guidelines. We will address any identified issues in the 2026 WSS update.

Task 2 - Document WSS Progress

Verdantas will review the information provided by the District regarding the progress made in addressing the issues of future developments near reservoirs, erosion control, and wildfire preparedness recommended in the 2021 WSS. This information will be summarized in the new WSS.

Task 3 – Field Survey

Verdantas will perform a field survey of the watershed to verify the watershed description presented in the previous WSS, evaluate the existing water supply systems and identify potential contaminant sources. The previous versions of the WSS will be the basis for this survey and the information will be updated, if necessary, based on findings from the field survey or information provided during the field survey or provided by the District.

Task 4 – Desktop Survey

Verdantas will review available public information including waste discharge permits, environmental reports and water quality data to identify potential contaminant sources and evaluate the level of water treatment provided. Verdantas will summarize the raw and treated water quality data provided by the District for the past 5 years.

Task 5 – Prepare WSS Update

The proposed table of contents for the WSS Update includes:

1. Introduction and Purpose
2. Summary of the 2021 WSS
3. Progress Made Since the 2021 WSS
4. Watershed Description
5. Water Supply Systems
6. Potential Contaminant Sources and Management Practices
7. Water Quality Assessment
8. Conclusions and Recommendations

Verdantas will prepare a draft version of the WSS for review by District staff before preparing a final version for DDW.

Task 6 - Project Management

This task includes general management of the project from initial kick-off through delivery of the final WSS. This task includes the development of monthly invoices that will be accompanied with monthly progress reports. The monthly invoices will detail hours by staff and include all expenses.

The monthly progress reports will summarize the services provided during the month, identify any outstanding issues, include monthly cost by task and identify the remaining budget.

Assumptions

- One (1) site visit is included for completion of the field survey
- Desktop survey information will be collected via telephone and/or internet; District staff will be used for field information collection
- The water quality data is available in electronic format in either spreadsheet or database format
- The watershed description and water supply system figures have not changed since the 2021 WSS
- Up to one (1) kick off meeting and one (1) review meeting to discuss District comments on the draft WSS Update (virtual)
- Scope of work to be completed by December 2026

Our proposed fee for this project is detailed in the attached Estimated Work Effort and Cost table. Our standard rate sheet for 2026 is also attached for reference. We look forward to assisting you with your Cosumnes WSS Update project. If you have any questions, or desire any additional information, please contact me at (530) 200-6309.

Sincerely,



Ashley Smith, PE
Principal, Senior Project Manager



Tim Hasler, PE
Principal, Group Leader

Attachments

Attachment A: Estimated Work Effort and Cost Table
Attachment B: 2026 Standard Rate Sheet

Attachment A:
Estimated Work Effort and Cost Table

Estimated Work Effort and Cost

2026 Cosumnes River Watershed Sanitary Survey Update

Task No.	Task Description	Principal/ QA/QC	Project Manager	Proj Engineer	Staff Engr 1	Admin 2	Verdantas Labor Hours	Total Labor (\$)	Total Cost (\$)
	2026	\$ 305.00	\$ 270.00	\$ 200.00	\$ 157.00	\$ 110.00			
Task 1 - Review Prior 2021 WSS and Regulatory Compliance									
		2	6	8	12	0	28	\$ 5,714	\$ 5,714
Task 2 - Document WSS Progress									
		0	2	4	4	0	10	\$ 1,968	\$ 1,968
Task 3 - Field Survey									
		0	8	8	8	0	24	\$ 5,016	\$ 5,016
Task 4 - Desktop Survey									
		0	8	24	32	0	64	\$ 11,984	\$ 11,984
Task 5 - Prepare WSS Update									
		4	4	16	24	0	48	\$ 9,268	\$ 9,268
Task 6 - Project Management									
		4	8	0	0	6	18	\$ 4,040	\$ 4,040
COLUMN TOTALS		10	36	60	80	6	144	\$ 37,990	\$ 37,990

TOTAL COST	\$ 37,990
-------------------	------------------

Attachment B:
2026 Standard Rate Sheet

VERDANTAS NorCal/OR AREA
2026 STANDARD FOLSOM BILLING RATE



Professional Services	Hourly Rate	Survey	Hourly Rate
Senior Consultant I	\$290.00	Survey Crew - 1 Man (Non-Prevailing)	\$230.00
Senior Consultant II	\$305.00	Survey Crew - 2 Man (Non-Prevailing)	\$320.00
Senior Consultant III	\$345.00	Survey Crew - 1 Man (Prevailing)	\$250.00
Project Manager I	\$230.00	Survey Crew - 2 Man (Prevailing)	\$360.00
Project Manager II	\$250.00		
Project Manager III	\$270.00	Support	Hourly Rate
Staff Engineer/Architect/Surveyor I	\$157.00	Administrative/Technical Editor I	\$95.00
Staff Engineer/Architect/Surveyor II	\$177.00	Administrative/Technical Editor II	\$110.00
Staff Engineer/Architect/Surveyor III	\$187.00	Project Specialist I	\$135.00
Engineer/Architect/Surveyor I	\$200.00	Project Specialist II	\$155.00
Engineer/Architect/Surveyor II	\$210.00	Group Leader	\$195.00
Engineer/Architect/Surveyor III	\$220.00	Technician I	\$125.00
Senior Engineer/Architect/Surveyor I	\$230.00	Technician II	\$135.00
Senior Engineer/Architect/Surveyor II	\$250.00	Technician III	\$160.00
Senior Engineer/Architect/Surveyor III	\$270.00	Senior Technician	\$170.00
		Building/Construction Inspector	\$190.00
CAD/Data Management	Hourly Rate	Resident Engineer	\$230.00
CAD Technician I	\$120.00	Materials/ Soils Tech (Prevailing)	\$190.00
CAD Technician II	\$130.00	Building/Construction Inspector (Prevailing)	\$207.00
CAD Technician III	\$155.00	Lead Inspector (Prevailing)	\$214.00
CAD Technician IV	\$165.00		

Notes

- Standard Billing Rates:** Our standard billing rates are reviewed no less than annually and may be adjusted at those times.
- Proposal Expiration:** Proposals are valid for at least 30 days, subject to change after 30 days; unless otherwise stated in the proposal.
- Prevailing Wages:** Our fees for prevailing wage work are based upon California prevailing wage laws and wage determinations. Unless specifically indicated in our proposal, costs for apprentice are not included. If we are required to have an apprentice on your project, additional fees will be charged. Prevailing wage rates will increase on July 1st of each year.
- Expert Testimony:** Litigation, expert witness, and all other legal and court related appearances will be billed at twice the standard fee schedule rate. There is a minimum eight-hour charge per day and a minimum overall fee of \$2,000.00 per case.
- Higher Hourly Rates:** Certain services, such as emergency/rapid response consulting, may be subject to higher hourly billing rates as agreed upon on a project-specific basis.
- Overtime:** Standard overtime rate is per California Labor Law and is billed at 1.5 or 2 times their hourly billing rate. Overtime rate for non-exempt field personnel working on a Verdantas observed holiday is billed at 2 times their hourly billing rate. Overtime rate for Prevailing wage work is per the California Department of Industrial Relations (DIR) determination and is multiplied at 1.5 to 2 times their hourly billing rate for overtime and double-time, respectively.
- Field Equipment and Supplies:** Field equipment and in-house supplies will be billed at fixed unit prices, subject to periodic updates.
- Subcontractors and Project Expenses:** All project-related expenses are chargeable at cost plus 10% or in accordance with the specific project agreement. Subcontractor charges, costs of rental of specialized equipment, and any other costs not associated with normal overhead are billed at cost plus 10% or in accordance with the specific project agreement.
- Mileage:** The mileage for personal vehicles will be billed at the current United States Internal Revenue Service reimbursement rate.
- Client Disclosures:** Client agrees to provide all information in Client's possession about actual or possible presence of buried utilities and hazardous materials on the project site, prior to fieldwork, and agrees to reimburse Verdantas for all costs related to unanticipated discovery of utilities and/or hazardous materials. Client is also responsible for providing safe and legal access to the project site for all Verdantas field personnel.



VERDANTAS NorCal/OR AREA
2026 STANDARD FOLSOM BILLING RATE



11. **Insurance & Limitation of Liability:** These rates are predicated on standard insurance coverage and a limit of Verdantas' liability equal to our total fees for a given project.
12. **General Terms and Conditions:** Please refer to the General Terms and Conditions for further details.





Rancho Murieta Community Services District

FY 2026-27

Proposed Budget



RESOLUTION NO. R2026-13

**A RESOLUTION OF THE BOARD OF DIRECTORS OF
THE RANCHO MURIETA COMMUNITY SERVICES DISTRICT
APPROVING THE BUDGET FOR FISCAL YEAR 2026-27**

WHEREAS, District departments have submitted estimates of budget requirements for FY26-27; and those estimates have been reviewed by the Interim General Manager, Director of Finance and Administration and Finance Committee; and

WHEREAS, the Director of Finance and Administration has submitted a proposed budget with the tabulations of the estimates together with proposed revisions to the Board of Directors; and

WHEREAS, the Board of Directors has reviewed and considered the proposed budget for FY26-27; and

WHEREAS, a public presentation and hearing was conducted for the budget for the FY26-27 on May 27, 2026, at 5:00 p.m. in the Board Room at 15160 Jackson Road, Rancho Murieta, CA 95683.

NOW, THEREFORE, BE IT RESOLVED AND ORDERED that (1) the proposed budget for FY26-27, as submitted by the District Director of Finance and Administration and as reviewed by the Board of Directors is a proper financial program for the budget period and constitutes the budget for FY26-27; and (2) the District's FY26-27 Budget is hereby adopted in the form attached hereto as Exhibit A and incorporated herein by this reference as presented at this meeting and ordered filed with the County Auditor of Sacramento County in accordance with Sections 53901 and 61110 of the Government Code.

PASSED, APPROVED AND ADOPTED by the Board of Directors of the Rancho Murieta Community Services District, Sacramento County, California, at a meeting held on the 17th day of June 2026, by the following roll call vote:

AYES:

NOES:

ABSENT:

ABSTAIN:

John Merchant, President of the Board
Rancho Murieta Community Services District

[SEAL]

Attest:

Dyanne Fleet, Interim District Secretary



RANCHO MURIETA COMMUNITY SERVICES DISTRICT

15160 JACKSON ROAD
RANCHO MURIETA, CALIFORNIA 95683
916-354-3700
FAX – 916-354-2082

*“Your Independent Local Government Agency Providing
Water, Wastewater, Drainage, Security, and Solid Waste Services”*

BOARD MEMBERS

John Merchant	President
Linda Butler	Vice President
Tim Maybee	Director
Randy Jenco	Director
Bill Gere	Director

STAFF

Amelia Wilder	Interim General Manager
Cecilia Min	Director of Finance & Administration
Dyanne Fleet	Interim District Secretary/Clerk of the Board
Branden Arino	Security Supervisor
Travis Bohannon	Interim Director of Operations
Patrick Enright	District General Counsel



Rancho Murieta Community Services District Information Sheet

Mission Statement

The mission of Rancho Murieta Community Services District is to take a leadership role in responding to the needs of the residents. The District will deliver superior community services efficiently and professionally at a reasonable cost while responding to and sustaining the enhanced quality of life the community desires.

Purpose

The Rancho Murieta Community Services District (CSD) was formed in 1982 by State Government Code 61000 to provide essential services in Rancho Murieta. The District provides the following services:

- Security
- Water supply collection, treatment, and distribution
- Wastewater collection, treatment, and reuse
- Storm drainage collection and disposal
- Solid waste collection

The District encompasses 3,500 acres, five and a half square miles. Land uses included in the approved master plan call for residential development on 1,981 acres of single-family residences, townhouses, apartments, and mobile homes for a total of 5,189 units. Current estimates indicate Rancho Murieta has over 2,900 households with a population of over 5,900 persons. The District currently maintains over \$56,000,000 in plant, property, and equipment assets.

Population

Highlights from the Census 2020 demographic profiles show total population in Rancho Murieta at 5,903. The average household size is 2.48. Current estimates indicate Rancho Murieta has 2,369 households with a population of over 5,900.

Latent Powers

In June of 1982, after local registered voters petitioned the County and public hearings were held, the voters approved the formation of the Rancho Murieta Community Services District (CSD or District) and elected five directors. While the election resulted in voter approval for CSD to provide the following services:

- Police protection/security services
- Road construction and maintenance
- Landscape maintenance
- Drainage construction and maintenance
- Public recreation and street lighting.

Subsequently, the voters authorized the CSD to provide all municipal services authorized in the California Government Code, as well as some special services authorized by the legislature. Those services approved by the voters of Rancho Murieta include:

- Fire protection
- Ambulance
- Libraries
- Mosquito abatement
- Airports
- Garbage or refuse
- Transportation services
- Water and sewer
- Conversion of existing overhead electric
- Communication facilities to underground locations
- Construction improvements of bridges, culverts, curbs, gutters, drains
- Works incidental to road construction and maintenance

Later special legislation expanded the District's latent powers to include:

- Television and television related services
- Burglar and fire alarm facilities
- Issuance of revenue bonds
- Enforcement of CC&R's (Covenants, Conditions, and Restrictions)
- Hydroelectric power generating facilities and transmission lines

While the District has the authority to provide all of these services, at this time, **CSD only provides Water, Sewer, Drainage, Security and Solid Waste services.**

Security

Two of the most important reasons for living in Rancho Murieta are privacy and security. Entrances into the private residential areas have automated access lanes for residents and managed access lanes for visitors.

Water Source and Storage

The source of water for all uses is primarily the Cosumnes River plus some direct rainfall into reservoir watersheds. State water rights permit diversion for municipal usage only during winter and spring months. Raw water is diverted from the river at Granlees Dam and pumped into reservoirs Calero, Chesbro, and Clementia.

Water Treatment and Distribution

Raw water, primarily from reservoirs Calero and Chesbro, is treated to potable standards at a treatment plant located at the north end of Clementia reservoir.

Wastewater Collection, Storage, and Reuse

Imposed at the formation of Rancho Murieta, state regulations prohibit any discharge of wastewater into the Cosumnes River. Regulations require treated wastewater to be used for irrigation of golf courses, parks, and common areas.

When needed for irrigation, the stored, partially treated wastewater is processed through a state-of-the-art tertiary system. The golf courses use this treated effluent to supplement and/or replace raw river water and to reduce wastewater reservoir levels.

Storm Drainage

Storm water and irrigation runoff are collected in the drainage system throughout the community. A major component of Rancho Murieta's storm drainage system is the extensive amount of natural swales, streams, and tributaries. Runoff is filtered through detention ponds prior to being returned to the Cosumnes River. In addition, the District maintains levees that protect the low-lying areas from flooding.

Solid Waste

In 2005 Rancho Murieta CSD added Solid Waste Disposal to the services it provides for the community. Under a 10-year contract with Rancho Murieta CSD, California Waste Recovery Systems provides waste disposal services to residents of Rancho Murieta. These now include compliance with SB 1383, Organic Waste Management.

Governance

The affairs of the District are directed by a five-member Board of Directors elected at large by the registered voters residing in the District. The people who are elected are residents and have the same concerns as residents. The board members serve four-year staggered terms. The District board is responsible, among other things, for passing ordinances, adopting the budget, appointing committees, and hiring the District's General Manager. The District's manager is responsible for carrying out the policies and ordinances of the District board, for overseeing the day-to-day operations of the District, and for appointing the heads for the various departments.

All business of the District is conducted at regular monthly meetings of the Board. These regular meetings are held on the third Wednesday of every month at the District Office located at 15160 Jackson Road with the public session starting at 5:00 p.m. All meetings are open to the public.

Long Term Financial Planning

The District currently maintains over \$56,000,000 in plant, property, and equipment assets. The District's Reserve Policy 2012-07 is a financial policy guided by sound accounting principles of public fund management. The policy establishes several reserve funds to minimize adverse annual budgetary impacts from anticipated and unanticipated District expenses.

The following reserves are covered under the policy:

- Capital Replacement Fee Reserve (Water, Sewer and Security) – fees are collected for the future replacement of existing facilities and major equipment
- Capital Improvement Fee Reserve – provide funds for the orderly and timely expansion of the District's facilities to meet future demand and to maintain and/or improve the District's existing level of service
- Water Augmentation Fee Reserve – provides funds for the orderly and timely expansion of the District's water supply system to meet future demands of the undeveloped lands within the District's existing boundaries during an equivalent 1976-77 drought event
- Capital Improvement Connection Fee Reserve (Water and Sewer) - fees previously collected as a primary source of funds for the development of additional water and wastewater capacity and is set at a level which will defray the costs of providing additional: treatment and/or reclamation facilities, major trunk and transmission pipelines and facilities for pumping when such facilities are needed
- Rate Stabilization Fund Reserve (Water, Sewer and Security) – offsets revenue shortages due to economic hardships and/or unforeseen major expenses

Cash Management Policies and Practices

The District's Investment Policy 2016-01 is a conservative policy guided by three principles of public fund management. In specific order of importance, the three principles are:

- Safety of Principal. Investments shall be undertaken in a manner which first seeks to preserve portfolio principal.
- Liquidity. Investments shall be made with maturity dates that are compatible with cash flow requirements, and which will permit easy and rapid conversion into cash, at all times, without a substantial loss of value.
- Return on Investment. Investments shall be undertaken to produce an acceptable rate of return after first consideration for principal and liquidity.

Investments are accounted for in accordance with the provisions of GASB Statement No. 31, which requires governmental entities to report certain investments at fair value in the balance sheet and recognize the corresponding change in fair value of investments in the year in which the change occurred. The District reports its investments at fair value based on quoted market information obtained from fiscal agents or other sources.

**RANCHO MURIETA COMMUNITY SERVICES DISTRICT
 ORGANIZATIONAL CHART—June 2026
 39.5 Authorized Full Time Positions**

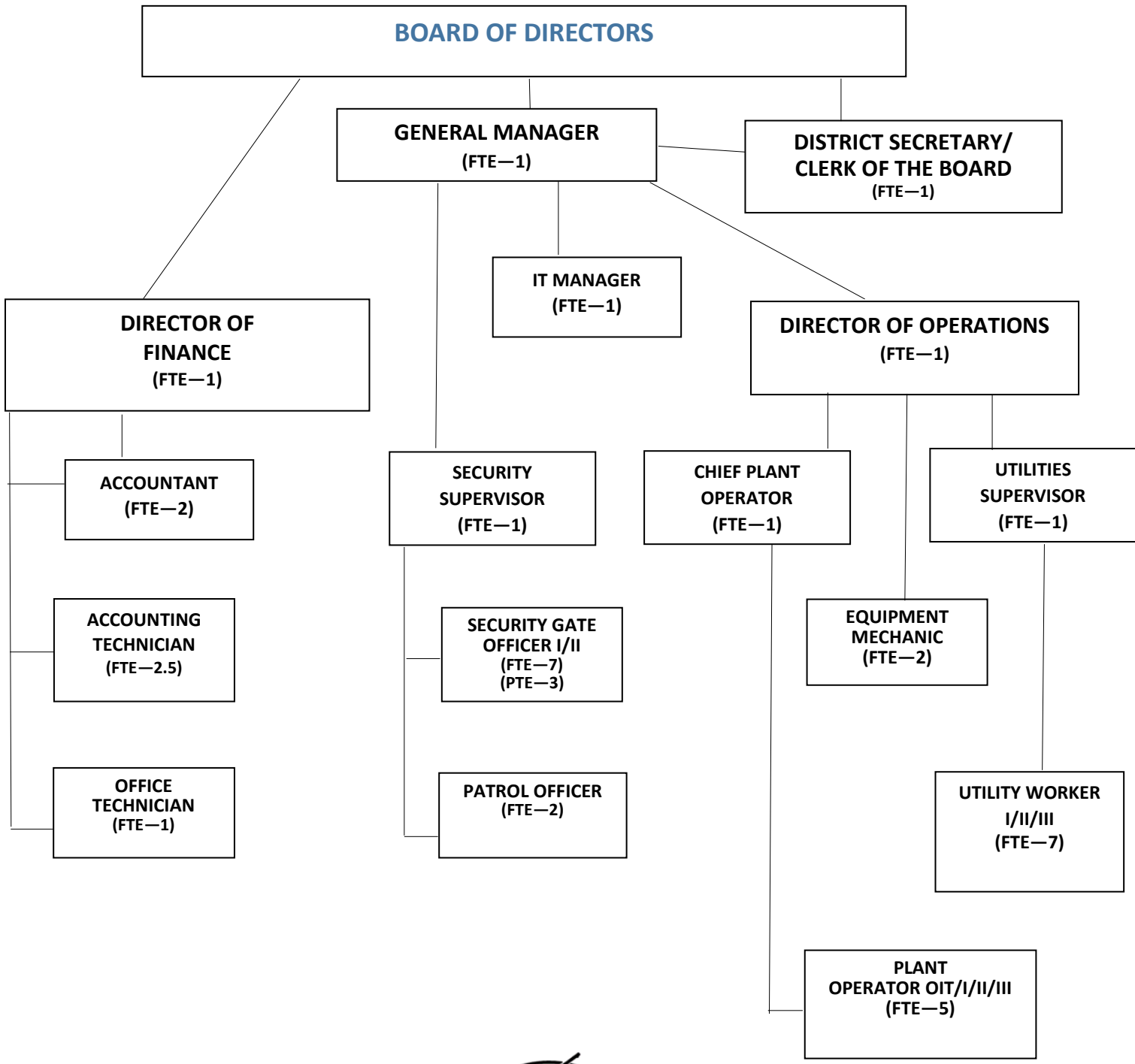

Rancho Murieta Community Services District

Position Listing

	2022-23 Approved	2023-24 Approved	2024-25 Approved	2025-26 Actual	2026-27 Budget
Adminiatration Dept.					
GENERAL MANAGER	1.0	1.0	1.0	1.0	1.0
DISTRICT SECRETARY	1.0	1.0	1.0	1.0	1.0
DIRECTOR OF FINANCE	-	1.0	1.0	1.0	1.0
ACCOUNTANT	1.0	1.0	1.0	1.0	2.0
ACCOUNTING TECHNICIAN	3.0	3.0	2.0	3.0	2.5
IT MANAGER	-	-	1.0	1.0	1.0
OFFICE TECHNICIAN	1.0	1.0	1.0	1.0	1.0
<i>SUBTOTAL</i>	<i>7.0</i>	<i>8.0</i>	<i>8.0</i>	<i>9.0</i>	<i>9.5</i>
Water/WasteWater/Drainage Dept.					
DIRECTOR OF OPERATIONS		1.0	1.0	1.0	1.0
CHIEF PLANT OPERATOR	1.0	1.0	1.0	1.0	1.0
PLANT OPERATOR I, II, III	4.0	4.0	4.0	5.0	5.0
OPERATOR IN TRAINING	1.0	1.0	1.0	-	-
UTILITIES SUPERVISOR	1.0	1.0	1.0	1.0	1.0
UTILITY WORKER I, II, III	5.0	5.0	5.0	7.0	7.0
EQUIPMENT MECHANIC	1.0	1.0	1.0	1.0	2.0
<i>SUBTOTAL</i>	<i>13.0</i>	<i>14.0</i>	<i>14.0</i>	<i>16.0</i>	<i>17.0</i>
Security Dept.					
SECURITY SUPERVISOR	1.0	1.0	1.0	1.0	1.0
GATE OFFICER	8.0	8.0	8.0	7.0	7.0
PATROL OFFICER	5.0	2.0	3.0	4.0	2.0
PART-TIME GATE OFFICER	1.0	-	-	3.0	3.0
TEMP GATE OFFICER	1.0	-	-	-	-
<i>SUBTOTAL</i>	<i>16.0</i>	<i>11.0</i>	<i>12.0</i>	<i>15.0</i>	<i>13.0</i>
<i>TOTAL</i>	<i>36.0</i>	<i>33.0</i>	<i>34.0</i>	<i>40.0</i>	<i>39.5</i>

**Rancho Murieta Community Service District
 Operation Revenue Summary
 Approved Budget FY 26/27**

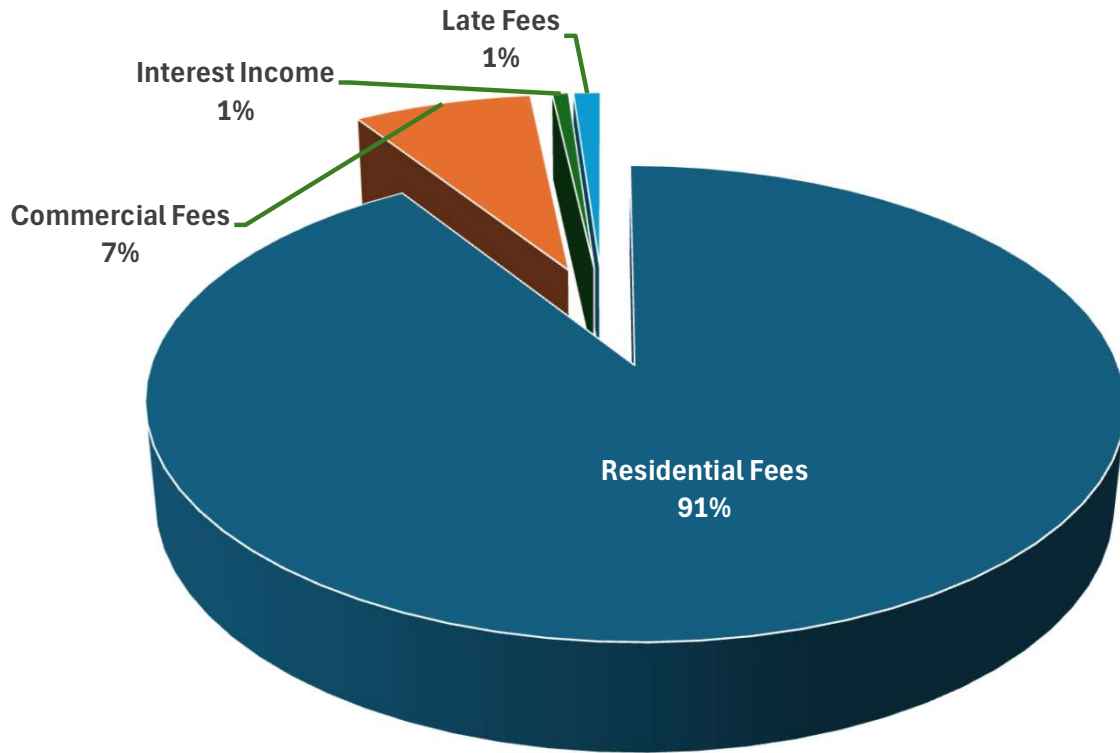

Composition of Operation Revenue

Residential Fees	\$ 11,238,600	91%
Commercial Fees	897,288	7%
Interest Income	81,564	1%
Late Fees	135,588	1%
	\$ 12,353,040	0%

**Rancho Murieta Community Service District
Expense Summary
Approved Budget FY 26/27**

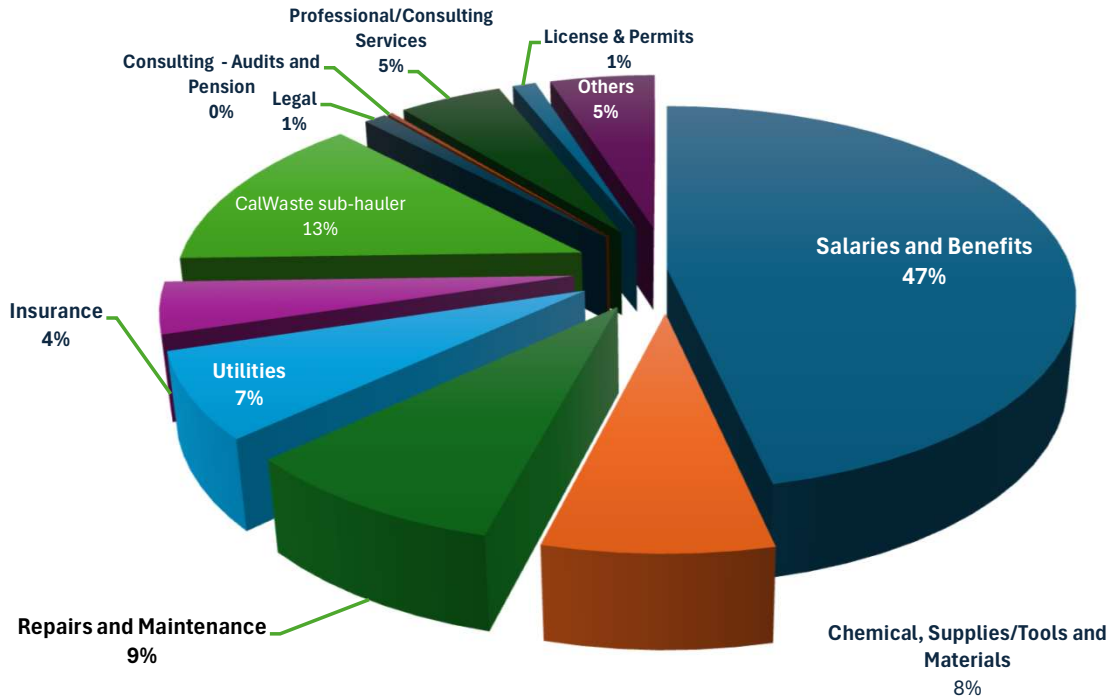

Composition of Expenses

Salaries and Benefits	\$ 5,735,712	46%
Chemical, Supplies/Tools and Materials	937,024	8%
Repairs and Maintenance	1,115,800	9%
Utilities	884,000	7%
Insurance	530,780	4%
CalWaste sub-hauler	1,641,183	13%
Legal	131,208	1%
Consulting - Audits and Pension	30,000	0%
Professional/Consulting Services	599,203	5%
License & Permits	135,600	1%
Others	610,387	5%
	\$ 12,350,897	

**Rancho Murieta Community Service District
Reserve Summary
Approved Budget FY 26/27**

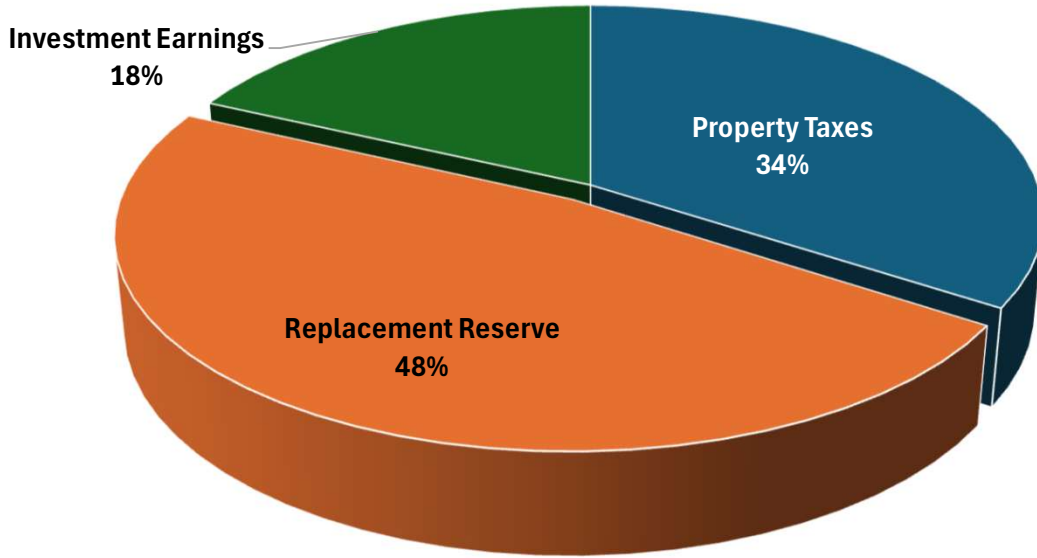

Composition of Reserves

Property Taxes	\$ 1,017,851	34%
Replacement Reserve	1,423,548	48%
Investment Earnings	539,304	18%
	\$ 2,980,703	

**Rancho Murieta Community Service District
Statement of Revenue and Expenses - Summary
Approved Budget FY 26/27**

	Water	WasteWater	Drainage	Solid Waste	Security	Total
Operation						
Revenue	5,310,600	3,344,550	252,138	1,800,372	1,645,380	12,353,040
Expenses						
Operation	(3,734,559)	(1,994,237)	(149,415)	(1,641,183)	(1,220,909)	(8,740,303)
General and Administration	(1,769,191)	(1,155,390)	(144,424)	(144,424)	(397,165)	(3,610,594)
Total Expenses	(5,503,750)	(3,149,628)	(293,839)	(1,785,607)	(1,618,074)	(12,350,897)
Operating Income/(Expenses)	(193,150)	194,922	(41,701)	14,765	27,306	2,143
NonOperation						
Property Taxes Reserve	559,818	447,854	10,179			1,017,851
Reserve	1,000,140	858,612	11,352		92,748	1,962,852
Professional Fees: Water Attorney	(99,992)					(99,992)
	1,459,966	1,306,466	21,531		92,748	2,880,711
Net Income (Loss)	1,266,816	1,501,388	(20,170)	14,765	120,054	2,882,854
IRC Reserve Rate FY 27	49%	32%	4%	4%	11%	100%
IRC Reserve Rate FY 26	55%	22%	7%	4%	12%	100%

Rancho Murieta Community Service District
Statement of Revenue and Expenses By Fund
Approved Budget FY 26/27

	Water	Waste Water	Drainage	Solid Waste	Security	Grand Total
Operation Revenue						
Residential Fees	4,698,402	3,179,298	205,380	1,779,312	1,376,208	11,238,600
Commercial Fees	512,958	99,300	41,034		243,996	897,288
Interest Income	39,960	26,100	3,264	3,264	8,976	81,564
Late Fees	59,280	39,852	2,460	17,796	16,200	135,588
Operation Revenue Total	5,310,600	3,344,550	252,138	1,800,372	1,645,380	12,353,040
Operating Expenses						
Salaries	1,048,404	523,036	25,470		801,384	2,398,294
Salaries - Overtime	72,036	32,052	84		20,724	124,896
Payroll Taxes	16,380	15,864	400		19,560	52,204
Employee Benefits - Health, vision, dental, life insurance	246,666	224,978	7,392		253,418	732,454
Workers compensation insurance	79,548	39,420	1,812		58,368	179,148
Regulatory expenses - Inspections	98,738	28,398				127,136
Regulatory expenses - Lab Testing	23,556	39,580				63,136
Chemicals	494,463	79,057	18,000			591,520
Repairs and Maintenance - Building/Ground	260,425	261,276	29,704		12,000	563,405
Repairs and Maintenance - Equipment	298,249	135,168	936			434,353
Repairs and Maintenance - Vehicle	26,004	26,004			3,000	55,008
Rental/Lease expenses	80,000	107,004				187,004
Contractual Services	105,911			1,641,183		1,747,094
Tools and Supplies	234,918	15,590	54,996			305,504

**Rancho Murieta Community Service District
Statement of Revenue and Expenses By Fund
Approved Budget FY 26/27**

	Water	Waste Water	Drainage	Solid Waste	Security	Grand Total
Small Equipment	40,000					40,000
License & Permits	58,526	66,291	8,007		2,776	135,600
Uniform and Clothings	14,556				3,759	18,315
Office Supplies	2,268	2,268	1,664		6,272	12,472
Software License/IT Support					16,200	16,200
Membership and Subscription	2,250	22,000				24,250
Utilities	325,385	207,413			11,136	543,934
Telecommunications	93,060	93,060			7,356	193,476
Training and Seminars	86,668	51,232	600		3,000	141,500
HR and recruitment costs	8,575	8,575	350			17,500
Travel and Mileage	15,972	15,972			1,956	33,900
Employee events	2,000					2,000
Operating Expenses Total	3,734,559	1,994,237	149,415	1,641,183	1,220,909	8,740,303
General&Administrative						
Admin Allocation	1,769,191	1,155,390	144,424	144,424	397,165	3,610,594
G&A Allocation Total	1,769,191	1,155,390	144,424	144,424	397,165	3,610,594
NonOperation						
Professional/Consulting Services: Water Studies	99,992					99,992
NonOperation Total	99,992					99,992
Property Taxes						
Property Taxes	559,818	447,854	10,179			1,017,851

**Rancho Murieta Community Service District
Statement of Revenue and Expenses By Fund
Approved Budget FY 26/27**

	Water	Waste Water	Drainage	Solid Waste	Security	Grand Total
Property Taxes Total	559,818	447,854	10,179			1,017,851
Reserve						
Water Cap Replacement Reserve	716,436	707,112				1,423,548
Investment Earnings Restricted	283,704	151,500	11,352		92,748	539,304
Reserve Total	1,000,140	858,612	11,352		92,748	1,962,852
Grand Total	1,266,816	1,501,388	20,170	14,765	120,054	2,882,854

Rancho Murieta Community Service District
Statement of Revenue and Expenses - Monthly
Approved Budget FY 26/27

	Jul	Aug	Sep	Oct	Nov	Dec	Jan	Feb	Mar	Apr	May	Jun	Grand Total
Operation Revenue													
Residential Fees	861,270	1,123,860	861,270	749,240	749,240	1,011,830	861,270	861,270	1,123,860	1,011,830	1,011,830	1,011,830	11,238,600
Commercial Fees	65,253	85,662	65,253	63,886	63,886	84,295	65,253	65,253	85,662	84,295	84,295	84,295	897,288
Interest Income	6,797	6,797	6,797	6,797	6,797	6,797	6,797	6,797	6,797	6,797	6,797	6,797	81,564
Late Fees	11,299	11,299	11,299	11,299	11,299	11,299	11,299	11,299	11,299	11,299	11,299	11,299	135,588
Operation Revenue Total	944,619	1,227,618	944,619	831,222	831,222	1,114,221	944,619	944,619	1,227,618	1,114,221	1,114,221	1,114,221	12,353,040
Operating Expenses													
Salaries	197,064	197,064	197,064	197,064	197,064	197,064	202,651	202,651	202,651	202,651	202,651	202,651	2,398,294
Salaries - Overtime	10,408	10,408	10,408	10,408	10,408	10,408	10,408	10,408	10,408	10,408	10,408	10,408	124,896
Payroll Taxes	4,354	4,350	4,350	4,350	4,350	4,350	4,350	4,350	4,350	4,350	4,350	4,350	52,204
Employee Benefits - Health, vision, dent	58,887	58,887	58,887	58,887	58,887	58,887	63,188	63,295	63,196	63,188	63,188	63,077	732,454
Workers compensation insurance	14,929	14,929	14,929	14,929	14,929	14,929	14,929	14,929	14,929	14,929	14,929	14,929	179,148
Regulatory expenses - Inspections		19,912		9,398	9,398	9,398			79,031				127,136
Regulatory expenses - Lab Testing	5,161	5,161	5,161	5,161	5,761	5,161	5,161	5,161	5,161	5,761	5,161	5,165	63,136
Chemicals	43,347	43,347	47,847	56,999	54,857	50,357	50,357	50,357	50,357	52,498	47,847	43,347	591,520
Repairs and Maintenance - Building/Gro	46,516	63,009	82,594	40,716	49,966	33,216	33,216	37,466	44,258	38,008	61,216	33,224	563,405
Repairs and Maintenance - Equipment	23,710	25,899	57,749	57,553	31,899	26,749	23,149	51,499	31,249	33,649	42,999	28,249	434,353
Repairs and Maintenance - Vehicle	3,584	15,584	3,584	3,584	3,584	3,584	3,584	3,584	3,584	3,584	3,584	3,584	55,008
Rental/Lease expenses	6,417	30,167	1,417	10,167	30,167	10,167	10,167	35,167	10,167	15,167	6,417	21,417	187,004
Contractual Services	146,683	142,792	154,716	141,748	146,969	159,948	137,433	136,056	149,088	141,401	136,424	153,836	1,747,094
Tools and Supplies	22,333	31,583	27,333	22,333	31,583	27,833	23,583	25,333	23,583	25,333	22,333	22,341	305,504
Small Equipment		10,000			10,000			10,000				10,000	40,000
License & Permits	69,921	12,399			4,200	46,304					2,776		135,600
Uniform and Clothings	2,466	2,466	1,253			1,213	1,213	1,213	2,426	2,426	1,213	2,426	18,315
Office Supplies	1,373	873	1,373	873	873	1,373	873	873	1,373	873	873	869	12,472
Software License/IT Support	1,800		1,800	1,800	1,800		1,800	1,800	1,800		1,800	1,800	16,200

**Rancho Murieta Community Service District
Statement of Revenue and Expenses - Monthly
Approved Budget FY 26/27**

	Jul	Aug	Sep	Oct	Nov	Dec	Jan	Feb	Mar	Apr	May	Jun	Grand Total
Membership and Subscription	4,000	13,750	100	500	100	100	100	100	100	5,200	100	100	24,250
Utilities	46,542	46,078	45,798	45,188	43,870	43,174	44,400	44,372	45,132	45,776	46,880	46,724	543,934
Telecommunications	16,123	16,123	16,123	16,123	16,123	16,123	16,123	16,123	16,123	16,123	16,123	16,123	193,476
Training and Seminars	10,250	10,250	10,250	10,250	10,250	28,750	10,250	10,250	10,250	10,250	10,250	10,250	141,500
HR and recruitment costs			8,925										17,500
Travel and Mileage	325	325	15,325	325	325	325	325	15,325	325	325	325	325	33,900
Employee events	334				333	333	333			333		334	2,000
Operating Expenses Total	736,528	775,357	766,987	708,356	737,696	749,746	657,594	740,313	769,542	692,234	701,848	695,530	8,740,303
General&Administrative													
Salaries	92,881	92,881	92,881	92,881	92,881	92,881	102,677	102,677	102,677	102,677	102,677	102,677	1,173,348
Salaries - Board	1,200	1,200	1,200	1,200	1,200	1,200	1,200	1,200	1,200	1,200	1,200	1,200	14,400
Salaries - Overtime	1,090	1,090	1,090	1,090	1,090	1,090	1,090	1,090	1,090	1,090	1,090	1,090	13,080
Payroll Taxes	1,785	1,785	1,785	1,785	1,785	1,785	1,785	1,785	1,785	1,785	1,785	1,785	21,420
Employee Benefits - Health, vision, dent	34,325	34,325	34,325	34,325	34,325	34,325	37,456	37,456	37,456	37,456	37,456	37,456	430,680
Other Post Employment Benefits	42,544	42,544	42,544	42,544	42,544	42,544	42,544	42,544	42,544	42,544	42,544	42,544	510,528
Worker's Comp Insurance	7,105	7,105	7,105	7,105	7,105	7,105	7,105	7,105	7,105	7,105	7,105	7,105	85,260
Audit and Accounting Fees		6,000	6,000	6,000	6,000	6,000							30,000
Bank Charges and processing fees	636	636	2,236	636	636	2,236	636	636	2,236	636	636	2,236	14,026
Board and Committee Meetings	1,000	1,000	1,000	5,000	9,379	12,879	4,000	4,000	4,000	1,000	1,000	1,000	45,257
Community Communications	10,813	2,496	2,163	6,546	5,413	2,163	2,163	2,163	5,746	4,263	2,163	2,163	48,255
Consulting Fees/Contractual Staffing	2,500	8,900	18,900	8,900							2,200		41,400
HR and recruitment Fees	4,000	6,500	6,500	6,500	6,500	4,000	4,000	4,000	4,000	4,000	4,000	4,000	58,000
Insurance	44,232	44,232	44,232	44,232	44,232	44,232	44,232	44,232	44,232	44,232	44,232	44,228	530,780
Legal	10,934	10,934	10,934	10,934	10,934	10,934	10,934	10,934	10,934	10,934	10,934	10,934	131,208
Repairs and Maintenance	5,543	6,217	5,726	5,726	5,101	5,284	5,101	4,976	4,793	4,976	4,793	4,793	63,034
Office Supplies	3,425	3,425	3,425	3,425	3,425	3,425	3,425	3,425	3,425	3,425	3,425	3,425	41,100

**Rancho Murieta Community Service District
Statement of Revenue and Expenses - Monthly
Approved Budget FY 26/27**

	Jul	Aug	Sep	Oct	Nov	Dec	Jan	Feb	Mar	Apr	May	Jun	Grand Total
Postage	1,396	1,396	1,396	1,396	1,396	1,396	1,396	1,396	1,396	1,396	1,396	1,396	16,752
Software License/IT Support	10,660	10,660	21,160	10,660	10,660	21,160	10,660	10,660	21,160	10,660	10,660	21,160	169,920
Membership and Subscription	833	833	837	833	833	833	833	833	833	833	833	833	10,000
Utilities	13,114	12,535	12,553	11,625	8,844	6,430	6,829	6,784	9,481	12,288	14,024	13,435	127,942
Telecommunications	1,554	1,554	1,554	1,554	1,554	1,554	1,554	1,554	1,554	1,554	1,554	1,554	18,648
Training and Seminars				2,000		940	940	940	1,880				6,700
Travel and Mileage	488	488	488	488	488	488	488	488	488	488	488	488	5,856
Employee events	250	250	250	250	250	250	250	250	250	250	250	250	3,000
General&Administrative Total	292,307	298,985	320,283	307,634	296,574	305,133	291,297	291,127	310,264	294,791	296,444	305,751	3,610,594
NonOperation													
Professional/Consulting Services: Water	8,333	8,333	8,333	8,333	8,333	8,333	8,333	8,333	8,333	8,333	8,333	8,329	99,992
NonOperation Total	8,333	8,333	8,333	8,333	8,333	8,333	8,333	8,333	8,333	8,333	8,333	8,329	99,992
Property Taxes													
Property Taxes								559,818			447,854	10,179	1,017,851
Property Taxes Total								559,818			447,854	10,179	1,017,851
Reserve													
Water Cap Replacement Reserve	118,629	118,629	118,629	118,629	118,629	118,629	118,629	118,629	118,629	118,629	118,629	118,629	1,423,548
Investment Earnings Restricted	44,942	44,942	44,942	44,942	44,942	44,942	44,942	44,942	44,942	44,942	44,942	44,942	539,304
Reserve Total	163,571	163,571	163,571	163,571	163,571	163,571	163,571	163,571	163,571	163,571	163,571	163,571	1,962,852
Grand Total	71,022	308,514	12,587	29,531	47,810	214,580	150,966	628,235	303,050	282,434	719,021	278,361	2,882,854

CAPTIAL IMPROVEMENT PROJECTS

FY 26/27

Rancho Murieta Community Service District
Capital Improvement Budget
Approved Budget FY 26/27

Sources of Reserve	Connection Fees - Developers	Reserve Charge - Utility	Connection Fees - Developers	
Reserve Fundings	Capital Improvement	Capital Replacement	Security Impact Fee	Grand Total
Urban Water Mgmt Plan	500,000			500,000
Rebuild Granlees 125hp pumps		40,000		40,000
Replace remaining 2 trains of membranes & HMI		824,920		824,920
Replace 2003 Ford F150 Truck #216		60,000		60,000
Replace 2003 Ford F150 Truck #814		50,000		50,000
Smart Meter Endpoint & Meter Replacement		200,000		200,000
Combination Sewer / Vactor Truck Lease 8 yrs	141,000			141,000
Work Truck for New Mechanic	75,000			75,000
SCADA WTP Servers saved to the Cloud		40,000		40,000
Rate Study: Developers, Utility and Reserve 5 yrs	30,000			30,000
20 Year Capital Improvement Planning Project	100,000			100,000
Office equipments/Board speakers/Others		25,000		25,000
A/C units - Admin buildings		25,000		25,000
Cameras for new construction WWTP and admin		23,000		23,000
Update hardware for connectivity to WWTP		5,000		5,000
Computer Need to facilitate Windows 11		5,000		5,000
Go Access conversion			10,000	10,000
Go Access hardware			20,000	20,000
Radio Motorola - 5 yrs lease			5,000	5,000
Grand Total	846,000	1,297,920	35,000	2,178,920

Rancho Murieta Community Service District
Capital Improvement Budget by Project Number and Fund
Approved Budget FY 26/27

Project Number	Fund	Project Name	Capital Improvement	Capital Replacement	Security Impact Fee	Grand Total
27-CIPP-1	200	20-Year Capital Improvement Planning Project	33,333			33,333
27-CIPP-1	250	20-Year Capital Improvement Planning Project	33,334			33,334
27-CIPP-1	260	20-Year Capital Improvement Planning Project	33,333			33,333
27-ADMINAC-2	100	A/C units - Admin buildings		25,000		25,000
27-WWTPCAM-3	250	Cameras for new construction WWTP and admin		23,000		23,000
27-VACTOR-4	250	Combination Sewer / Vactor Truck Lease 8 yrs	141,000			141,000
27-COMPU-5	100	Computer Need to facilitate Windows 11		5,000		5,000
27-GOACCES-6	500	Go Access conversion			10,000	10,000
27-GOACCES-7	500	Go Access hardware			20,000	20,000
27-ADMINEQP-9	100	Office equipments/Board speakers/Others		25,000		25,000
27-RADIO-8	500	Radio Motorola - 5 yrs lease			5,000	5,000
27-RATESTDY-19	200	Rate Study: Developers, Utility and Reserve 5 yrs	30,000			30,000
27-GRLEPUMP-10	200	Rebuild Granlees 125hp pumps		40,000		40,000
27-TRUCK-11	200	Replace 2003 Ford F150 Truck #216		30,000		30,000
27-TRUCK-11	250	Replace 2003 Ford F150 Truck #216		30,000		30,000
27-TRUCK-12	200	Replace 2003 Ford F150 Truck #814		25,000		25,000
27-TRUCK-12	250	Replace 2003 Ford F150 Truck #814		25,000		25,000
27-MEMBRNE-13	200	Replace remaining 2 trains of membranes & HMI		824,920		824,920
27-SCADA-14	200	SCADA WTP Servers saved to the Cloud		40,000		40,000
27-METERENDPT-15	200	Smart Meter Endpoint & Meter Replacement		200,000		200,000
27-WWTPCONN-16	250	Update hardware for connectivity to WWTP		5,000		5,000
27-UWMP-17	200	Urban Water Mgmt Plan	500,000			500,000
27-TRUCK-18	200	Work Truck for New Mechanic	75,000			75,000
Grand Total			846,000	1,297,920	35,000	2,178,920



CAPITAL FUND:

PROJECT TITLE: Rebuild Granlees 125hp pumps



CIP #

PROJECT BUDGET: \$40,000.00

PROJECT DESCRIPTION: Rebuild the 2 125 hp pumps at Granlees Pump Station

JUSTIFICATION:

1. These are the pumps that the district relies on to pump water from Consumnes River
2. These pumps have not been rebuilt in over 10 years.

ENVIRONMENTAL OR REGULATORY ISSUES:

RISK ASSESSMENT:

If these pumps fail, we will not be able to pump water from the river.

REPLACEMENT:



CAPITAL FUND:

PROJECT TITLE: Replace remaining 2 trains of membranes & HMI



CIP #

PROJECT BUDGET: \$824,920.00

PROJECT DESCRIPTION: Replace remaining membranes & HMI that are 11+ years old

JUSTIFICATION:

The membrane modules have a life cycle of about 10 years. The district has only replaced about 1/3 of the total membranes. We are starting to see multiple catastrophic failures in the other 2/3 remaining membranes. The HMI is also at the end of its life cycle and needs to be replaced.

ENVIRONMENTAL OR REGULATORY ISSUES:

RISK ASSESSMENT:

REPLACEMENT:



CAPITAL FUND:

PROJECT TITLE: Replace 2003 Ford F150 Truck



CIP # 26-200-03

PROJECT BUDGET: \$60,000.00

PROJECT DESCRIPTION: Replace 2003 Ford F150 Truck #216

JUSTIFICATION:

This is one of the oldest trucks in our fleet. It is a 2003 and has 70,000 miles on it. It is constantly breaking down and costing more money to fix than what the truck is worth. This is a potential safety hazard for whomever is driving this truck.

ENVIRONMENTAL OR REGULATORY ISSUES:

RISK ASSESSMENT:

REPLACEMENT:



CAPITAL FUND:

PROJECT TITLE: Replace 2003 Ford F150 Truck



CIP # 26-200-02

PROJECT BUDGET: \$50,000.00

PROJECT DESCRIPTION: Replace 2003 Ford F150 Truck #814

JUSTIFICATION:

This is one of the oldest trucks in our fleet. It is a 2003 and has 118551.3 miles on it. It is constantly breaking down and costing more money to fix than what the truck is worth. This is a potential safety hazard for whomever is driving this truck.

ENVIRONMENTAL OR REGULATORY ISSUES:

RISK ASSESSMENT:

REPLACEMENT:



CAPITAL FUND:

PROJECT TITLE: Smart Meter Endpoint & Meter Replacement



CIP #

PROJECT BUDGET: \$200,000.00

PROJECT DESCRIPTION: To replace 1,000 Endpoints and 130 water meters

JUSTIFICATION:

- Improve billing accuracy
- Reduce estimated billing
- Increase revenue capture
- Improve leak detection capability
- Enhance customer service
- Reduce manual meter reading labor

ENVIRONMENTAL OR REGULATORY ISSUES:

RISK ASSESSMENT:

REPLACEMENT:



CAPITAL FUND:

PROJECT TITLE: Combination Sewer / Vactor Truck



CIP #

PROJECT BUDGET: \$141,000 / yr lease for 8 yr

PROJECT DESCRIPTION:

JUSTIFICATION:

The Services District currently relies on aging equipment and/or contracted services to perform essential water maintenance, wastewater maintenance and emergency response.

Acquisition of a Vacall AJV1015 will:

- Reduce sanitary sewer overflows (SSOs)
- Lower long-term contracting costs
- Increase emergency response efficiency
- Provide direct support to water distribution main repairs



ENVIRONMENTAL OR REGULATORY ISSUES:

RISK ASSESSMENT:

Increased Risk of sewer overflows. Higher emergency repair costs.

REPLACEMENT:



CAPITAL FUND:

PROJECT TITLE: Work Truck for New Mechanic



CI

P #

PROJECT BUDGET: \$ 75,000.00

PROJECT DESCRIPTION: Purchase work truck for new mechanic position

JUSTIFICATION: The District will need to purchase a new work truck for the new mechanic position if approved.

ENVIRONMENTAL OR REGULATORY ISSUES:

RISK ASSESSMENT:

REPLACEMENT:



CAPITAL FUND:

PROJECT TITLE: WTP Servers saved to the Cloud

CIP #

PROJECT BUDGET: \$40,000.00

PROJECT DESCRIPTION: To back up water plant SCADA servers to the cloud

JUSTIFICATION:

- Increased security for SCADA System.
- Back-up stored offsite just incase of server crash.

ENVIRONMENTAL OR REGULATORY ISSUES:

RISK ASSESSMENT:

REPLACEMENT:



FUND: Water, Wastewater, Drainage

PROJECT TITLE: 20-year Capital Improvement Planning & 5 - Year Rate Study



CIP#:

PROJECT BUDGET: \$130,000

PROJECT DESCRIPTION: 20-year Capital Improvement Planning Project (CIPP) and 5-year Rate Study

JUSTIFICATION:

To ensure RMCS D maintains sufficient financial resources to support ongoing operations as well as planned projects and system improvements. These studies are essential for forecasting future equipment and infrastructure costs and ensuring that utilities are financially prepared for new installations necessary to protect public health and safety.

Regular rate studies play a critical role in maintaining the long-term financial stability of utility systems and supporting the timely execution of essential capital projects. They provide valuable insight into whether a community can sustain the financial demands associated with operational expenses and proposed improvements. In addition, rate studies help evaluate the feasibility of planned initiatives and are a key component of responsible fiscal governance.

Rising inflation has significantly increased both construction and operating costs for utility systems, making it increasingly important for utilities to conduct rate studies on a regular basis. These studies ensure that rates remain aligned with current economic conditions and reflect the true cost of maintaining and operating the utility system.

This project will update the most recent CIPP completed by Lumos & Associates in FY 23/24 for the water and wastewater system. The underlying data is now approximately four years old and no longer reflects current system conditions. This update will also expand the scope to include drainage infrastructure if possible.

The updated CIPP will serve as a foundational input for the five-year rate study, which was previously deferred due to the lack of finalized financial audit data. The rate study will provide updated projections for existing customer monthly rates, developer fees and charges, capital reserve funding rates, and administrative and operational fees.



In addition, this project will include the drafting of public notices and will involve close coordination with the RMCS D to ensure effective communication with customers regarding the need for fee adjustments, including any proposed changes to rate structures, if applicable. The overall goal is to ensure that the process is conducted as transparently and clearly as possible, providing customers with a strong understanding of the basis for any proposed changes.

The time frame for this project is as follow:

1. CIPP July 26 to Oct 26
2. Rate Studies Nov 26 to Jan 27 finalize before the start of the next budget cycle



CAPITAL FUND:

PROJECT TITLE: GoAccess to replace ABDI



CIP #

PROJECT BUDGET: \$71,184 This amount will be adjusted after the security committee.

PROJECT DESCRIPTION: Replace ABDI Gate Entry System

JUSTIFICATION:

For several years, the ABDI gate entry system has been utilized for security gate operations and patrol functions; however, the system has become outdated and has presented ongoing challenges with reliability and customer support. Evaluation of the GoAccess gate entry platform has identified a modern, technology-driven solution that would significantly enhance operational efficiency and access control. GoAccess incorporates advanced AI-based License Plate Recognition (LPR), allowing authorized vehicles to enter the community without reliance on barcodes, thereby improving traffic flow and reducing delays during peak hours and holidays. Additionally, the system offers the capability to implement visitor lane kiosks with virtual guard functionality, which can streamline guest entry processes while reducing staffing demands and associated labor costs. Overall, upgrading to a modern access control system will improve service levels, increase system reliability, and align the District with current security technology standards while supporting long-term operational efficiency.

ENVIRONMENTAL OR REGULATORY ISSUES:

RISK ASSESSMENT:

REPLACEMENT:

Pricing

Gate Software

SERVICE	PRICE
Full GoAccess Platform subscription	\$1,249/month
Guest Lane License Plate and A.I. Recognition Enhancement (Optional) - Including 14 camera channels	\$249/month + \$99/month per additional channel x13 = \$1,536/month
Remote Kiosk Access with Security Dialing Capability and QR Code Scanning	\$249/month
Data Export/Import Service - Onboarding Support and Marketing Service (All resident support, both for the transition and ongoing, is handled by GoAccess to ensure a high adoption rate)	\$9,998 (one time)

Gate Hardware

ITEM	PRICE
7x Pre-Provisioned PDK Access Control Panels (3 year MFG warranty)	\$17,346 (one time)
7x NVIDIA A.I. LPR Recognition Server	\$34,181 (one time)
10" TouchScreen Outdoor Kiosk	\$7,483 (one-time)
2N Indoor viewing unit + mounting	\$2,176 (one-time)

Total GoAccess Investment

ITEM	PRICE
Total Monthly Membership	\$3,034/month
Total Hardware + Implementation	\$71,184 (one-time)



Rancho Murieta Community Services District

Monthly Billing Rates Effective 07/01/2026 ~ 06/30/2027 Per property type

Residential Monthly Rates	
Water base	\$ 106.46
Water variable usage per cubic foot	\$ 0.039295
Water Treatment Plant Debt Service	\$ -
Sewer	\$ 118.34
Drainage Tax	\$ 5.99
Security	\$ 34.15

Murieta Village Monthly Rates	
Water base	\$ 106.46
Water variable usage per cubic foot	\$ 0.039295
Water Treatment Plant Debt Service	\$ -
Sewer	\$ 118.34
Drainage Tax	\$ 4.01
Security	\$ 8.24

Villa Monthly Rates	
Water base	\$ 106.46
Water variable usage per cubic foot	\$ 0.039295
Water Treatment Plant Debt Service	\$ -
Sewer	\$ 118.34
Drainage Tax	\$ 4.01
Security	\$ 34.15

Murieta Gardens II Monthly Rates	
Water base	\$ 106.46
Potable Water variable usage per cubic foot	\$ 0.039295
Non-Potable Water variable usage per cubic foot	\$ -
Sewer	\$ 118.34
Drainage Tax	\$ 4.01
Security	\$ 8.24

Solid Waste Rates	
35 Gallon Cart	\$ 38.92
65 Gallon Cart	\$ 45.89
95 Gallon Cart	\$ 71.38
Additional Garbage Carts	
35 Gallon Cart	\$ 10.77
65 Gallon Cart	\$ 14.36
95 Gallon Cart	\$ 33.31
Additional Recycling Carts (in excess of 1 recycle cart)	
35 Gallon Cart	N/A
65 Gallon Cart	\$ 8.88
95 Gallon Cart	\$ 8.88
Additional Green Waste Carts (in excess of 2 carts)	
35 Gallon Cart	N/A
65 Gallon Cart	\$ 8.88
95 Gallon Cart	\$ 8.88
District Admin/Franchise Fee	\$ 3.14
Sacramento County Surcharge	\$ 3.14

Vacant or Unmetered lot Monthly Rates	
Drainage Tax	\$ 5.98
Security Tax	\$ 26.81
Annual Water Availability	\$ 19.95
Annual Sewer Availability	\$ 17.99

Rate Change Tables

WATER

The proposed 2026-27 monthly bill increase for an average consumption residential metered lot is projected to be \$54.26 or 45.5% aggregate when including water usage rates.

Type of Fee	Current Rate FY 2025-26	Proposed FY 2026-27
Base Charge (w/o reserve contribution)	\$ 54.90	\$ 85.46
Reserve Contribution	\$ 16.00	\$ 21.00
Total Base Charge	\$ 70.09	\$ 106.46
Debt Service Charge	\$ 6.00	-
Usage Charge (per ccf)	\$ 2.71	\$ 3.93
Non-residential customers are charged one base charge per month per meter plus the reserve contribution times their water EDU (equivalent dwelling unit) value plus usage.		

WASTEWATER

The proposed 2026-27 monthly bill increase for a residential metered lot is projected to be \$40.73 or 52.5% aggregate.

Type of Fee	Current Rate FY 2025-26	Proposed FY 2026-27
Base Charge (w/o reserve contribution)	\$ 61.61	\$ 97.35
Reserve Contribution	\$ 16.00	\$ 21.00
Total Base Charge	\$ 77.61	\$ 118.35
Non-residential customers are charged the base charge plus the reserve contribution times their sewer EDU (equivalent dwelling unit) value.		

SOLID WASTE

The proposed 2026-27 monthly bill increase for a 65-gallon container is projected to be \$2.02 or 4.60%. This rate increase includes a monthly charge of \$3.14 SB 1383 Organics Waste, 4.60% CPI adjustment amounting to \$0.39, and a \$0.14 increase to the District Franchise Fee.

Type of Fee	Current Rate FY 2025-26	Proposed FY 2026-27
35 Gallon Cart	\$ 37.21	\$ 38.92
65 Gallon Cart	\$ 43.87	\$ 45.89
95 Gallon Cart	\$ 68.24	\$ 71.38
Additional Carts		
35 Gallon Cart	\$ 10.30	\$ 10.77
65 Gallon Cart	\$ 13.73	\$ 14.36
95 Gallon Cart	\$ 31.56	\$ 33.31
Additional Recycling Cart	\$ 8.49	\$ 8.88
Additional Green Waste Cart	\$ 8.49	\$ 8.88
District Admin/Franchise Fee	\$ 3.00	\$ 3.14
Sacramento County Surcharge	\$ 3.00	\$ 3.14

Rate Change Tables

DRAINAGE

The proposed 2026-27 monthly bill increase for an average residential metered lot is \$0.12 or 2%.

Type of Fee	Current Rate FY 2025-26	Proposed FY 2026-27	Max Rate FY 2026-27
Residential (per lot)			
Metered	\$ 5.87	\$ 5.99	\$ 5.99
Unmetered	\$ 5.87	\$ 5.99	\$ 5.99
The Villas	\$ 3.93	\$ 4.01	\$ 4.01
Murieta Village	\$ 3.93	\$ 4.01	\$ 4.01
Murieta Gardens	\$ 3.93	\$ 4.01	\$ 4.01
Non-Residential (per acre)			
Retail	\$ 29.38	\$ 29.97	\$ 29.97
Industrial/Warehouse	\$ 31.25	\$ 31.88	\$ 31.88
Light Industrial	\$ 23.89	\$ 23.96	\$ 24.37
Office	\$ 27.56	\$ 28.11	\$ 28.11
Landscape (golf course/park)	\$ 5.51	\$ 5.62	\$ 5.62
Murieta Equestrian Center	\$ 2.13	\$ 2.17	\$ 2.17
RMCC (Clubhouse/parking)	\$ 0.00	\$ 0.00	\$ 0.00
Airport	\$ 2.47	\$ 2.52	\$ 2.52
Geyer Property	\$ 18.37	\$ 18.74	\$ 18.74
Hotel/Extended Stay	\$ 29.40	\$ 29.99	\$ 29.99
Undeveloped Property (per acre)			
Residential	\$ 3.48	\$ 3.55	\$ 3.55
Non-Residential	\$ 3.48	\$ 3.55	\$ 3.55

SECURITY

The proposed 2026-27 monthly bill increase for a residential metered lot is 2% which equates to increases of \$0.67 and \$0.16 for inside the gates and outside the gates respectively.

Type of Fee	Current Rate FY 2024-25	Proposed FY 2025-26	Max Rate FY 2026-27
Residential (per lot)			
Inside the Gates			
Metered	\$ 33.48	\$ 34.15	\$ 34.15
Unmetered	\$ 26.29	\$ 26.82	\$ 26.82
Outside the gates	\$ 8.08	\$ 8.24	\$ 8.24
Non-Residential (per Building Square Foot)			
Highway Retail	\$ 0.3018	\$ 0.3078	\$ 0.3078
Other Retail/Commercial	\$ 0.0324	\$ 0.0330	\$ 0.0330
Industrial/Whse/Lt Industrial	\$ 0.0710	\$ 0.0724	\$ 0.0724
Office	\$ 0.0170	\$ 0.0173	\$ 0.0173
Institutional	\$ 0.0170	\$ 0.0173	\$ 0.0173
Public Utility	\$ 0.0541	\$ 0.0552	\$ 0.0552
Equestrian Center	\$ 0.0050	\$ 0.0051	\$ 0.0051
RMCC	\$ 0.0850	\$ 0.0867	\$ 0.0867
Airport	\$ 0.0216	\$.0220	\$.0220
Hotel/Extended Stay	\$ 0.0324	\$ 0.0330	\$ 0.0330
Undeveloped Property (per acre)			
	\$ 28.3223	\$ 28.8887	\$ 28.8887
	\$ 4.2205	\$ 4.3049	\$ 4.3049

SAMPLE BILL
Proposed FY 26-27

RANCHO MURIETA COMMUNITY SERVICES DISTRICT

Average Monthly Customer Bill							
Residential Metered Lot (Inside the gates)				Current Monthly Rates	Proposed Monthly Rates	\$	%
				July 1, 2025	July 1, 2026	Change	Change
Water	<i>Average Usage in CF</i>			1,815	1,707		
Residential Base (excluding reserves)				\$ 54.09	\$ 85.46	\$ 31.37	58.0%
Reserve Contribution				16.00	21.00	5.00	31.3%
<i>Water Base Charge</i>				70.09	106.46	36.37	51.9%
Water Usage (per 100 cubic foot)		\$2.71 → \$3.93		49.19	67.08	17.89	45.0%
Total Water				119.28	173.54	54.26	45.5%
WTP Debt Service Charge				6.00	-	(6.00)	
Wastewater							
Residential Base (excluding reserves)				61.61	97.34	35.73	58.0%
Reserve Contribution				16.00	21.00	5.00	31.3%
<i>Wastewater Base Charge</i>				77.61	118.34	40.73	52.5%
Solid Waste (avg. 65 Gallon Container)				43.87	45.89	2.02	4.60%
Solid Waste Administrative Fee				3.00	3.14	0.14	4.60%
District Administrative Fee				3.00	3.14	0.14	4.60%
Security Tax				33.48	34.15	0.67	2.00%
Drainage Tax				5.87	5.99	0.12	2.00%
Total RMCS D Bill				\$ 292.11	\$ 384.18	\$ 92.07	31.52%

The actual rate increases may be less than but in no case more than the proposed rates above.

Average Monthly Customer Bill							
Murieta Village				Current Monthly Rates	Proposed Monthly Rates	\$	%
				July 1, 2025	July 1, 2026	Change	Change
Water	<i>Average Usage in CF</i>			555	551		
Residential Base (excluding reserves)				\$ 54.09	\$ 85.46	\$ 31.37	58.0%
Reserve Contribution				16.00	21.00	5.00	31.3%
<i>Water Base Charge</i>				70.09	106.46	36.37	51.9%
Water Usage (per 100 cubic foot)		\$2.71 → \$3.93		15.04	21.64	6.60	45.0%
Total Water				85.13	128.10	42.97	50.5%
WTP Debt Service Charge				6.00	-	(6.00)	
Wastewater							
Residential Base (excluding reserves)				61.61	97.34	35.73	58.0%
Reserve Contribution				16.00	21.00	5.00	31.3%
<i>Wastewater Base Charge</i>				77.61	118.34	40.73	52.5%
Solid Waste (avg. 35 Gallon Container)				37.21	38.92	1.71	4.60%
Solid Waste Administrative Fee				3.00	3.14	0.14	4.60%
District Administrative Fee				3.00	3.14	0.14	4.60%
Security Tax				8.08	8.24	0.16	2.00%
Drainage Tax				3.93	4.01	0.08	2.00%
Total RMCS D Bill				\$ 223.96	\$ 303.89	\$ 79.93	35.69%

The actual rate increases may be less than but in no case more than the proposed rates above.

SAMPLE BILL
Proposed FY 26-27

RANCHO MURIETA COMMUNITY SERVICES DISTRICT

Average Monthly Customer Bill							
Retreats, Residences, and Riverview (Inside the Gates)				Current Monthly Rates	Proposed Monthly Rates	\$	%
				July 1, 2025	July 1, 2026	Change	Change
Water	<i>Average Usage in CF</i>			1,815	1,707		
Residential Base (excluding reserves)				\$ 54.09	\$ 85.46	\$ 31.37	58.0%
Reserve Contribution				16.00	21.00	5.00	31.3%
<i>Water Base Charge</i>				70.09	106.46	36.37	51.9%
Water Usage (per 100 cubic foot)	\$2.71	→ \$3.93		49.19	67.08	17.89	45.0%
Total Water				119.28	173.54	54.26	45.5%
WTP Debt Service Charge							
Wastewater							
Residential Base (excluding reserves)				61.61	97.34	35.73	58.0%
Reserve Contribution				16.00	21.00	5.00	31.3%
<i>Wastewater Base Charge</i>				77.61	118.34	40.73	52.5%
Solid Waste (avg. 65 Gallon Container)				43.87	45.89	2.02	4.60%
Solid Waste Administrative Fee				3.00	3.14	0.14	4.60%
District Administrative Fee				3.00	3.14	0.14	4.60%
Security Tax				33.48	34.15	0.67	2.00%
Drainage Tax				5.87	5.98	0.12	2.00%
			Total RMCS D Bill	\$ 286.10	\$ 384.17	\$ 98.07	34.28%

The actual rate increases may be less than but in no case more than the proposed rates above.

Average Monthly Customer Bill							
Townhomes (Inside the gates)				Current Monthly Rates	Proposed Monthly Rates	\$	%
				July 1, 2025	July 1, 2026	Change	Change
Water	<i>Average Usage in CF</i>			555	551		
Residential Base (excluding reserves)				\$ 54.09	\$ 85.46	\$ 31.37	58.0%
Reserve Contribution				16.00	21.00	5.00	31.3%
<i>Water Base Charge</i>				70.09	106.46	36.37	51.9%
Water Usage (per 100 cubic foot)	\$2.71	\$3.93		15.04	21.64	6.60	45.0%
Total Water				85.13	128.10	42.97	50.5%
WTP Debt Service Charge				6.00	-	(6.00)	
Wastewater							
Residential Base (excluding reserves)				61.61	97.34	35.73	58.0%
Reserve Contribution				16.00	21.00	5.00	31.3%
<i>Wastewater Base Charge</i>				77.61	118.34	40.73	52.5%
Solid Waste (avg. 35 Gallon Container)				37.21	38.92	1.71	4.60%
Solid Waste Administrative Fee				3.00	3.14	0.14	4.60%
District Administrative Fee				3.00	3.14	0.14	4.60%
Security Tax				33.48	34.15	0.67	2.00%
Drainage Tax				5.87	5.98	0.12	2.00%
			Total RMCS D Bill	\$ 251.29	\$ 331.77	\$ 80.48	32.03%

The actual rate increases may be less than but in no case more than the proposed rates above.

SAMPLE BILL
Proposed FY 26-27

RANCHO MURIETA COMMUNITY SERVICES DISTRICT							
Average Monthly Customer Bill							
Vacant or Unmetered Lot							
	Security Tax			\$ 26.29	\$ 26.81	\$ 0.53	2.00%
	Water Standby			12.63	19.95	7.32	58.00%
	Sewer Standby			11.39	17.99	6.60	58.00%
	Drainage Tax			5.87	5.98	0.12	2.00%
				\$ 56.16	\$ 70.73	\$ 14.57	25.94%
<i>The actual rate increases may be less than but in no case more than the proposed rates above.</i>							

RESOLUTION NO. R2026-13

**A RESOLUTION OF THE BOARD OF DIRECTORS OF
THE RANCHO MURIETA COMMUNITY SERVICES DISTRICT
APPROVING THE BUDGET FOR FISCAL YEAR 2026-27**

WHEREAS, District departments have submitted estimates of budget requirements for FY26-27; and those estimates have been reviewed by the Interim General Manager, Director of Finance and Administration and Finance Committee; and

WHEREAS, the Director of Finance and Administration has submitted a proposed budget with the tabulations of the estimates together with proposed revisions to the Board of Directors; and

WHEREAS, the Board of Directors has reviewed and considered the proposed budget for FY26-27; and

WHEREAS, a public presentation and hearing was conducted for the budget for the FY26-27 on May 27, 2026, at 5:00 p.m. in the Board Room at 15160 Jackson Road, Rancho Murieta, CA 95683.

NOW, THEREFORE, BE IT RESOLVED AND ORDERED that (1) the proposed budget for FY26-27, as submitted by the District Director of Finance and Administration and as reviewed by the Board of Directors is a proper financial program for the budget period and constitutes the budget for FY26-27; and (2) the District's FY26-27 Budget is hereby adopted in the form attached hereto as Exhibit A and incorporated herein by this reference as presented at this meeting and ordered filed with the County Auditor of Sacramento County in accordance with Sections 53901 and 61110 of the Government Code.

PASSED, APPROVED AND ADOPTED by the Board of Directors of the Rancho Murieta Community Services District, Sacramento County, California, at a meeting held on the 17th day of June 2026, by the following roll call vote:

AYES:

NOES:

ABSENT:

ABSTAIN:

John Merchant, President of the Board
Rancho Murieta Community Services District

[SEAL]

Attest:

Dyanne Fleet, Interim District Secretary

ORDINANCE NO. O2026-02

AN ORDINANCE OF THE BOARD OF DIRECTORS OF THE RANCHO MURIETA COMMUNITY SERVICES DISTRICT, AMENDING CHAPTER 14 OF THE DISTRICT CODE, RELATING TO WATER SERVICE CHARGES; AMENDING CHAPTER 15 OF THE DISTRICT CODE RELATING TO SEWER SERVICE CHARGES; AMENDING CHAPTER 16A OF THE DISTRICT CODE RELATING TO DRAINAGE SPECIAL TAX; AMENDING CHAPTER 21 OF THE DISTRICT CODE RELATING TO SECURITY SPECIAL TAX; AND AMENDING CHAPTER 31 OF THE DISTRICT CODE RELATING TO SOLID WASTE COLLECTION AND DISPOSAL SERVICE CHARGES AND LEAF COLLECTION

The Board of Directors of the Rancho Murieta Community Services District ordains as follows:

SECTION 1. Purpose and Authority. The purposes of this ordinance are to (a) increase the District water, sewer and solid waste collection and disposal service charges in order to reflect and provide for operation, maintenance and other cost increases due to inflation, increased regulatory costs, increased costs of supplies, services, labor and benefits, and other factors, and (b) increase the District drainage special tax and security special tax to implement the voter-authorized annual adjustments. This ordinance is adopted pursuant to California Constitution articles XIII C, section 2, and XIII D, section 6, Government Code sections 61115, 61121 and 61123, District Ordinances Nos. 98-1 and 98-2, and other applicable laws.

SECTION 2. Findings. The Board of Directors finds and determines as follows:

- (a) As calculated and demonstrated in the FY 2026-27 District budget, the increased service charges implemented by this ordinance have been fixed in amounts sufficient to pay the operating expenses of the District's water, sewer and solid waste operations, provide for and fund repairs and replacement of utility system works and equipment, provide for increased costs of regulatory compliance and fund financial reserves, and other costs.
- (b) The increased service charges are reasonably related to, and do not exceed, the District's cost of providing each of the services.
- (c) The revenues derived from the service charges do not exceed the funds required to provide the services and will not be used for any purpose other than the listed services.
- (d) The amount of the service charges imposed on each customer's parcel does not exceed the proportional cost of the particular service attributable to that parcel.
- (e) The District water, sewer and solid waste services are services that are actually used by and immediately available to the owner of each customer parcel.
- (f) No portion of these service charge increases are imposed for general governmental services.
- (g) As calculated and demonstrated in the FY 2026-27 District budget, the increased drainage and security special taxes implemented by this ordinance have been fixed in amounts as calculated and determined consistent with the annual tax adjustments as set forth in District Code chapters 16A and 21 and as authorized by the voters at the time of the approval of the special taxes.
- (h) The establishment, modification, structuring, restructuring and approval of the service charges and taxes as set forth in this ordinance are necessary and appropriate to continue to meet the District's costs for operation and maintenance, supplies and equipment,

financial reserves, and capital replacement needs, and to maintain a satisfactory level of services within the District service area.

- (i) The District Board of Directors has conducted a duly noticed public hearing on the proposed service charge increases in accordance with California Constitution article XIII D, section 6, and the Board did not receive a majority protest against any of the proposed service charge increases.

SECTION 3. Service Charge and Tax Adjustments; District Code Amendments

- l) The Water Code, Chapter 14, Section 7.00 Rates and Charges is amended as follows:
Section 7.05 Rates for Metered Service.

- (a) General metered service shall be as follows:

MONTHLY CHARGES

Base Charge	\$ 85.46
Reserve Charge	<u>\$ 21.00</u>
Total Basic Service Charge	\$106.46/mo

Usage charge per 100 cubic feet:

Basic volumetric rate per 100 cubic feet	\$ 3.93 per 100 cubic feet
--	----------------------------

- (b) Metered service to residential lots at Murieta Village and Murieta Gardens II shall be as follows:

MONTHLY CHARGES

Base Charge	\$ 85.46
Reserve Charge	<u>\$ 21.00</u>
Total Basic Service Charge	\$106.46/mo

Usage charge per 100 cubic feet:

Basic volumetric rate per 100 cubic feet	\$ 3.93 per 100 cubic feet
--	----------------------------

- (c) Non-Residential metered service shall be as follows:

MONTHLY CHARGES

Basic Service Charge for non-residential shall be calculated on an EDU basis

Monthly Charges

Basic Service Charge for non-residential metered service shall be calculated on number of meters and an EDU basis for each customer multiplied by the Basic Service Charge reflected in Section 7.05(a) above.

Usage charge per 100 cubic feet:

Basic volumetric rate per 100 cubic feet	\$ 3.93 per 100 cubic feet
--	----------------------------

II) The Sewer Code, Chapter 15, Section 7.00 Rates and Charges is amended as follows:

Section 7.03 Rates and Charges for Service. The monthly service charge for each premise receiving sewer service from the District shall be:

Residential or other premises, each unit		
Base rate		\$ 97.35 per month
Reserve contribution		<u>\$ 21.00 per month</u>
Total monthly service charge		\$118.35 per month

Murieta Village and Murieta Gardens II, per unit		
Base rate		\$ 97.35 per month
Reserve contribution		<u>\$ 21.00 per month</u>
Total monthly service charge		\$ 118.35 per month

Non-Residential

Monthly service charge for non-residential sewer service shall be calculated on an EDU basis for each customer multiplied by the residential service charge rate.

III) The Drainage Code, Chapter 16, Section 7.00 Rates and Charges is amended as follows:

Section 7.01 Rates and Charges: Drainage charges for operation and maintenance of the District's system shall be as set forth in Chapter 16A, Section 3.00.

The Drainage Code, Chapter 16A, Section 3.00 Drainage Tax, is amended as follows:

Section 3.00 Rates and Charges for Operation and Maintenance of the District's system shall be: Commencing July 1, 2026, property within the District shall be assessed a monthly drainage tax as follows. The maximum monthly tax rates shown reflect annual adjustments, per Section 5.00.

LAND USE		Monthly Special Tax Rates Fiscal Year 2026-27	Monthly Special Tax Rates Maximum Ceiling Rate Year 2026-27
DEVELOPED PROPERTY			
Residential			
Metered Developed	Per Lot	\$ 5.99	5.99
Unmetered Developed	Per Lot	\$ 5.99	5.99
The Villas	Per Lot	\$ 4.01	4.01
Murieta Village	Per Lot	\$ 4.01	4.01
Murieta Gardens	Per Lot	\$ 4.01	4.01
Non-Residential			
Retail	Per Acre	\$ 29.97	29.97
Industrial/Warehouse	Per Acre	\$ 31.88	31.88
Light Industrial	Per Acre	\$ 24.37	24.37
Office	Per Acre	\$ 28.11	28.11
Landscaped Areas (golf course & parks)	Per Acre	\$ 5.62	5.62
Murieta Equestrian Center	Per Acre	\$ 2.17	2.17

RMCC (club house & parking)	Per Acre	\$ 0.00	0.00
Airport	Per Acre	\$ 2.52	2.52
Geyer Property	Per Acre	\$ 18.74	18.74
Hotel/Ext Stay		\$ 29.99	29.99

UNDEVELOPED PROPERTY

Uses Drainage System

-Residential and Non-Residential	Per Acre	\$ 3.55	3.55
----------------------------------	----------	---------	------

IV) The Security Code, Chapter 21, Section 5.00 Security Tax, is amended as follows:

Commencing July 1, 2026, property within the District shall be assessed a monthly security tax as follows. The maximum tax rates shown reflect annual adjustments, per Section 5.00:

<u>LAND USE</u>	<u>Monthly Special Tax Rates Fiscal Year 2026-27</u>	<u>Monthly Special Tax Rates Maximum Ceiling Rate Year 2026-27</u>
DEVELOPED PROPERTY		
Residential per lot		
Inside Gates		
<i>Metered</i>	\$ 34.15	34.15
<i>Unmetered</i>	\$ 26.81	26.82
Outside Gate	\$ 8.24	8.24
Non-Residential per building square foot		
<i>Highway Retail</i>	\$ 0.3079	0.3078
<i>Other Retail/Commercial</i>	\$ 0.0330	0.0330
<i>Industrial/Warehouse/Lt Industrial</i>	\$ 0.0724	0.0724
<i>Office</i>	\$ 0.0173	0.0173
<i>Institutional</i>	\$ 0.0173	0.0173
<i>Public Utility</i>	\$ 0.0552	0.0552
<i>Equine Complex</i>	\$ 0.0051	0.0051
RMCC	\$ 0.0867	0.0867
Airport	\$ 0.0222	0.0220
Hotel/Ext. Stay	\$ 0.0330	0.0330
UNDEVELOPED PROPERTY – Per Acre		
Inside Gates	\$ 28.8888	28.8887
Outside Gates	\$ 4.3049	4.3049

V) The Solid Waste Collection and Disposal Code, Chapter 31, Section 4.0 Collection Rates, is amended as follows:

Section 4.03 Collections Rates. The monthly service charge shall be:

(1) Garbage Collection Services

35-gallon cart	\$ 38.92
65-gallon cart	\$ 45.89

95-gallon cart	\$ 71.38
(2) Additional Garbage Carts	
35-gallon cart	\$ 10.77
65-gallon cart	\$ 14.36
95-gallon cart	\$ 33.31
(3) Additional Recycling Cart (in excess of 1 recycled cart)	
35-gallon cart	N/A
65-gallon cart	\$ 8.88
95-gallon cart	\$ 8.88
(4) Additional Green Waste Cart (in excess of 2 green waste carts)	
35-gallon cart	N/A
65-gallon cart	\$ 8.88
95-gallon cart	\$ 8.88
(5) Sacramento County Surcharge	\$ 3.14
(6) District Admin/Franchise Fee	\$ 3.14

SECTION 4. Severability. If any section, subsection, subdivision, sentence, clause, phrase, or portion of this Ordinance or the application thereof to any person or place, is for any reason held to be invalid or unconstitutional by the final decision of any court of competent jurisdiction, the remainder of this Ordinance shall be and remain in full force and effect.

SECTION 5. Effective Date. This ordinance shall go into effect and be in full force and effect at 12:01 a.m. on the thirty-first (31st) day after its passage.

SECTION 6. Severability. If any section or provision of this ordinance or the application of it to any person, transaction or circumstance is held invalid or unenforceable, such invalidity or unenforceability shall not affect the other provisions of this ordinance that can be given effect without the invalid or unenforceable provision, and to this end the provisions of this ordinance are declared to be severable.

SECTION 7. Publication. The District Secretary shall cause this Ordinance to be at least once in a newspaper of general circulation published and circulated in the District within fifteen (15) days after its passage in accordance with Section 36933 of the Government Code.

INTRODUCED by the Board of Directors on the 27th day of May 2026.

PASSED AND ADOPTED by the Board of Directors of the Rancho Murieta Community Services District, Sacramento County, California, at a meeting held on the 17th day of June 2026, by the following roll call vote:

AYES:

NOES:
ABSENT:
ABSTAIN:

John Merchant, President of the Board
Rancho Murieta Community Services District

[seal]

ATTEST:

Dyanne Fleet, Interim District Secretary

DRAFT