



RANCHO MURIETA COMMUNITY SERVICES DISTRICT

15160 JACKSON ROAD
RANCHO MURIETA, CA 95683
916-354-3700
FAX – 916-354-2082

AGENDA

*“Your Independent Local Government Agency Providing
Water, Wastewater, Drainage, Security, and Solid Waste Services”*

REGULAR BOARD OF DIRECTORS MEETINGS ARE HELD
3rd Wednesday of Each Month

REGULAR BOARD MEETING

November 20, 2013

Closed Session 3:00 p.m. * Open Session 5:00 p.m.

RMCS D Administration Building – Board Room

15160 Jackson Road

Rancho Murieta, CA 95683

BOARD MEMBERS

Gerald Pasek	President
Roberta Belton	Vice President
Betty Ferraro	Director
Paul Gumbinger	Director
Michael Martel	Director

STAFF

Edward R. Crouse	General Manager
Darlene Gillum	Assistant General Manager
Greg Remson	Security Chief
Paul Siebensohn	Director of Field Operations
Suzanne Lindenfeld	District Secretary

**RANCHO MURIETA COMMUNITY SERVICES DISTRICT
REGULAR BOARD MEETING
November 20, 2013**

Closed Session 3:00 p.m. - Open Session 5:00 p.m.

AGENDA

	RUNNING TIME
1. CALL TO ORDER - Determination of Quorum - President Pasek (Roll Call)	3:00
2. ADOPT AGENDA (Motion)	3:05
3. SPECIAL ANNOUNCEMENTS AND ACTIVITIES (5 min.)	3:10
4. CLOSED SESSION	3:15
<i>Under Government Code section 54956.8: Conference with Real Property Negotiators - Real Property APN 128-0080-067; APN 128-0080-068; APN 128-0080-069; APN 128-0080-076; and APN 128-0100-029. Real Property Agency Negotiator: Edward R. Crouse, General Manager. Negotiating Party: CSGF Rancho Murieta, LLC, BBC Murieta Land, LLC, Murieta Retreats, LLC, PCCP CSGF RB PORTFOLIO, LLC. Under Negotiation: Price and Terms.</i>	
<i>Under Government Code section 54956.8: Conference with Real Property Negotiators – Real Property APN 128-0080-067 and APN 128-0100-029. Real Property Agency Negotiator: Edward R. Crouse, General Manager. Negotiating Party: Cosumnes River Land, LLC and Rancho Murieta Properties, LLC. Under Negotiation: Price and Terms.</i>	
<i>Conference with Legal Counsel – Anticipated Litigation. Initiation of litigation pursuant to Government Code Section 54956.9(c): (One Potential Case).</i>	
<i>Conference with Legal Counsel – Anticipated Litigation. Significant Exposure to Litigation Pursuant to 54956.9(b): (Three (3) Potential Cases).</i>	
<i>Under Government Code 54957: Public Employee Performance Review: Title: General Manager.</i>	
<i>Under Government Code 54957.6: Conference with Labor Negotiator. Agency Designated Representative: Gerald Pasek. Unrepresented Employee: District General Manager.</i>	

- 5. OPEN SESSION** 5:00
- The Board will discuss items on this agenda, and may take action on those items, including informational items and continued items. The Board may also discuss other items that do not appear on this agenda, but will not act on those items unless action is urgent, and a resolution is passed by a two-thirds (2/3) vote declaring that the need for action arose after posting of this agenda.*
- The running times listed on this agenda are only estimates and may be discussed earlier or later than shown. At the discretion of the Board, an item may be moved on the agenda and or taken out of order. **TIMED ITEMS** as specifically noted, such as Hearings or Formal Presentations of community-wide interest, will not be taken up earlier than listed.*
- 6. REPORT ACTION FROM CLOSED SESSION** 5:05
- 7. COMMENTS FROM THE PUBLIC** 5:10
- Members of the public may comment on any item of interest within the subject matter jurisdiction of the District and any item specifically agendized. Members of the public wishing to address a specific agendized item are encouraged to offer their public comment during consideration of that item. With certain exceptions, the Board may not discuss or take action on items that are not on the agenda.*
- If you wish to address the Board at this time or at the time of an agendized item, as a courtesy, please state your name and address, and reserve your comments to no more than 3 minutes so that others may be allowed to speak.*
- 8. CONSENT CALENDAR (Motion) (Roll Call Vote) (5 min.)** 5:15
- All the following items in Agenda Item 8 will be approved as one item if they are not excluded from the motion adopting the consent calendar.*
- a. Approval of Board Meeting Minutes**
 - 1. October 16, 2013 Regular Board Meeting
 - 2. October 25, 2013 Special Board Meeting
 - b. Committee Meeting Minutes (Receive and File)**
 - 1. November 1, 2013 Communication & Technology Committee Meeting
 - 2. November 6, 2013 Personnel Committee Meeting
 - 3. November 7, 2013 Improvements Committee Meeting
 - 4. November 7, 2013 Finance Committee Meeting
 - 5. November 7, 2013 Security Committee Meeting
 - c. Approval of Bills Paid Listing**
- 9. STAFF REPORTS (Receive and File) (5 min.)** 5:20
- a.** General Manager's Report
 - b.** Administration/Financial Report
 - c.** Security Report
 - d.** Water/Wastewater/Drainage Report

- | | | |
|------------|---|------|
| 10. | CORRESPONDENCE (5 min.) | 5:25 |
| 11. | ADOPT THE DRAFT TITLE 22 ENGINEERING REPORT
(Discussion/Action) (Motion) (10 min.) | 5:30 |
| 12. | APPROVE SACRAMENTO AIR QUALITY MANAGEMENT DISTRICT
GENERATOR PERMIT FEE (Discussion/Action) (Motion) (5 min.) | 5:40 |
| 13. | APPROVE SACRAMENTO MUNICIPAL UTILITY DISTRICT NEW SERVICES
COMMITMENT APPLICATION FEE (Discussion/Action) (Motion) (5 min.) | 5:45 |
| 14. | DISCUSS THE DISTRICT PROVIDING FUNDING FOR THE NEW NORTH GATE
PROJECT (Discussion/Action) (15 min.) | 5:50 |
| 15. | APPROVE FINAL SECURITY SURVEILLANCE CAMERA PLAN
(Discussion/Action) (Motion) (Roll Call Vote) (10 min.) | 6:05 |
| 16. | REPORT BACK ON FINANCING AND SERVICES AGREEMENT
(Discussion/Action) (5 min.) | 6:15 |
| 17. | DISCUSS WATER TREATMENT PLANT EXPANSION FINANCING ALTERNATIVES
(Discussion/Action) (10 min.) | 6:20 |
| 18. | APPROVE TRANSFERS TO RESERVE FUNDS
(Discussion/Action) (Motion) (15 min.) | 6:30 |
| 19. | ADOPT RESOLUTION 2013-04, PREQUALIFICATION OF BIDDERS ON PUBLIC
WORKS CONTRACTS; PROVIDE DIRECTION CONCERNING PREQUALIFICATION
ON WATER TREATMENT PLANT EXPANSION PROJECT
(Discussion/Action) (Motion) (Roll Call Vote) (10 min.) | 6:45 |
| 20. | DISCUSS NON-DIRECTOR PARTICIPATION ON DISTRICT COMMITTEES
(Discussion/Action) (5 min.) | 6:55 |
| 21. | DISCUSS USE OF DISTRICT LETTERHEAD FOR DIRECTORS' PERSONAL
OPINIONS/COMMENTS (Discussion/Action) (5 min.) | 7:00 |
| 22. | APPROVE CONTROLLER JOB DESCRIPTION
(Discussion/Action) (Motion) (Roll Call Vote) (5 min.) | 7:05 |
| 23. | APPROVE ACCOUNTING AND HUMAN RESOURCES SPECIALIST JOB
DESCRIPTION (Discussion/Action) (Motion) (Roll Call Vote) (5 min.) | 7:10 |







- 24. APPROVE REVISED JOB DESCRIPTIONS** 7:15
(Discussion/Action) (Motion) (Roll Call Vote) (10 min.)
- a. Director of Administration
 - b. Accounting Assistant I
 - c. Accounting Assistant II
 - d. Office Assistant I
 - e. Office Assistant II

- 25. REVIEW AND SELECT CONFERENCE/EDUCATION OPPORTUNITIES** 7:25
(Discussion/Action) (Motion) (5 min.)

- 26. MEETING DATES/TIMES FOR THE FOLLOWING:** (5 min.) 7:30

Next Regular Board Meeting: December 18, 2013

Committee Meeting Schedule:

 Personnel	December 4, 2013 at 9:00 a.m.
 Improvements	December 5, 2013 at 8:30 a.m.
 Finance	December 5, 2013 at 9:30 a.m.
 Security	December 5, 2013 at 10:00 a.m.
 Communications	December 6, 2013 at 9:00 a.m.
 Joint Security -	T.B.A.
 Parks -	T.B.A.

- 27. COMMENTS/SUGGESTIONS – BOARD MEMBERS AND STAFF** 7:35
In accordance with Government Code 54954.2(a), Directors and staff may make brief announcements or brief reports of their own activities. They may ask questions for clarification, make a referral to staff or take action to have staff place a matter of business on a future agenda.

- 28. ADJOURNMENT (Motion)** 7:40

"In accordance with California Government Code Section 54957.5, any writing or document that is a public record, relates to an open session agenda item and is distributed less than 72 hours prior to a regular meeting, will be made available for public inspection in the District offices during normal business hours. If, however, the document is not distributed until the regular meeting to which it relates, then the document or writing will be made available to the public at the location of the meeting."

Note: This agenda is posted pursuant to the provisions of the Government Code commencing at Section 54950. The date of this posting is October 11, 2013. Posting locations are: 1) District Office; 2) Plaza Foods; 3) Rancho Murieta Association; 4) Murieta Village Association.

RANCHO MURIETA COMMUNITY SERVICES DISTRICT

Board of Directors Meeting

MINUTES

October 16, 2013

4:00 p.m. Closed Session * 5:00 p.m. Open Session

1. CALL TO ORDER/ROLL CALL

President Gerald Pasek called the regular meeting of the Board of Directors of Rancho Murieta Community Services District to order at 4:00 p.m. in the District meeting room, 15160 Jackson Road, Rancho Murieta. Directors present were Gerald Pasek, Roberta Belton, and Michael Martel. Also present were Edward R. Crouse, General Manager; Darlene Gillum, Assistant General Manager; Greg Remson, Security Chief; Paul Siebensohn, Director of Field Operations; and Suzanne Lindenfeld, District Secretary. Directors Betty Ferraro and Paul Gumbinger were absent.

2. ADOPT AGENDA

Motion/Belton to adopt the agenda. **Second/Martel. Ayes: Pasek, Belton, and Martel. Noes: None. Absent: Ferraro and Gumbinger.**

3. SPECIAL ANNOUNCEMENTS AND ACTIVITIES

None.

4. BOARD ADJOURNED TO CLOSED SESSION AT 4:03 P.M. TO DISCUSS THE FOLLOWING ITEMS:

Under Government Code section 54956.8: Conference with Real Property Negotiators - Real Property APN 128-0080-067; APN 128-0080-068; APN 128-0080-069; APN 128-0080-076; and APN 128-0100-029. Real Property Agency Negotiator: Edward R. Crouse, General Manager. Negotiating Party: CSGF Rancho Murieta, LLC, BBC Murieta Land, LLC, Murieta Retreats, LLC, PCCP CSGF RB PORTFOLIO, LLC. Under Negotiation: Price and Terms.

Conference with Legal Counsel – Anticipated Litigation. Initiation of litigation pursuant to Government Code Section 54956.9(c): (One Potential Case).

Conference with Legal Counsel – Anticipated Litigation. Significant Exposure to Litigation Pursuant to 54956.9(b): (Two (2) Potential Cases).

Director Gumbinger arrived at 4:08 p.m.

5/6. BOARD RECONVENED TO OPEN SESSION AT 5:02 P.M. AND REPORTED THE FOLLOWING:

Under Government Code section 54956.8: Conference with Real Property Negotiators - Real Property APN 128-0080-067; APN 128-0080-068; APN 128-0080-069; APN 128-0080-076; and APN 128-0100-029. Real Property Agency Negotiator: Edward R. Crouse, General Manager. Negotiating Party: CSGF Rancho Murieta, LLC, BBC Murieta Land, LLC, Murieta Retreats, LLC, PCCP CSGF RB PORTFOLIO, LLC. Under Negotiation: Price and Terms. Nothing to report.

Conference with Legal Counsel – Anticipated Litigation. Initiation of litigation pursuant to Government Code Section 54956.9(c): (One Potential Case). Nothing to report.

Conference with Legal Counsel – Anticipated Litigation. Significant Exposure to Litigation Pursuant to 54956.9(b): (Two (2) Potential Cases). Nothing to report.

7. COMMENTS FROM THE PUBLIC

Ted Hart asked how much Rancho Murieta Association (RMA) is over budget for the new North Gate. Ed Crouse stated he does not want to get into specifics but that the original plan was 25% over but the design has since been modified to bring the cost down. President Pasek stated that RMA wants the District to contribute \$200,000 towards the new gate. Director Belton asked when the design was going to be put out for public comment. Director Gumbinger stated that will happen once the design has been finalized.

Director Martel stated that the response letter Ed Crouse sent to RMA regarding the request for \$200,000 is Ed's opinion and not his.

Mo Chaudhry commented on the 30% Design Report. Mr. Chaudhry stated the District should check into being exempt from paying sales tax since the District is a government agency and suggested staff look into other SCADA systems.

Mr. Chaudhry also stated that he has some books and a video on re-organizing agencies and offered to let the Board and staff borrow them before the next budget is approved.

8. CONSENT CALENDAR

Motion/Gumbinger to adopt the consent calendar. **Second/Belton. Ayes: Pasek, Belton, Gumbinger, and Martel. Noes: None. Absent: Ferraro.**

9. STAFF REPORTS

Under Agenda Item 9 c, Director Belton commented on the increase in crime in the community.

Under Agenda Item 9 d, President Pasek asked about the follow up letter being sent to California Department of Public Health (CDPH). Paul Siebensohn stated that he is in the process of writing the letter.

10. CORRESPONDENCE

No comments.

11. PRESENTATION OF THE 2012-13 FINAL AUDIT, BY LARRY BAIN, CPA

Larry Bain, CPA, gave a brief summary of the 2012-13 Audit Report. Mr. Bain stated it was a clean opinion. A question and answer period followed.

Director Martel commented on his meeting with Mr. Bain and Darlene prior to the Board meeting to answer the list of questions he had. Director Martel stated the meeting went well and he has a better understanding. There are five (5) questions outstanding and those responses will be provided to him in writing.

President Pasek stated he had already requested Darlene give a presentation on the budget process to the Board in the near future.

President Pasek asked about the refunding of any monies from the early pay off of the Mello Roos. Darlene stated that will be decided once all facilities have been completed. Director Martel asked if there will be a final reconciliation of the funds collected and spent after the Mello Roos has been paid off. Mr. Bain stated that the reconciliations are done annually. Darlene stated she has a spread sheet that has that information.

Director Belton left at 5:44 p.m.

12. ADOPT RECYCLED WATER STANDARDS

Ed Crouse gave a brief summary of the recommendation to adopt the Recycled Water Standards prepared by Kevin Kennedy, AECOM. Ed stated that the standards are for new development to use in planning and constructing their recycled water systems.

Motion/Gumbinger to adopt the Recycled Water Standards prepared by Kevin Kennedy, AECOM. **Second/Martel. Ayes: Pasek, Gumbinger and Martel. Noes: None. Absent: Belton and Ferraro.**

13. REPORT BACK ON FINANCING AND SERVICES AGREEMENT

Ed Crouse gave a brief update on the Financing and Services Agreement. PCCP has provided the additional legal fee deposit funds last week. The Special Board Meeting for the Financing and Services Agreement (FSA) is scheduled for October 25, 2013 at 9:00 a.m.

Staff is completing revisions requested by the Board as well as clarifications related to the water treatment plant construction the District initiated.

Cosumnes River Land will have a separate FSA which will include the Murieta Gardens project and the remaining lands.

14. REPORT BACK ON WATER TREATMENT PLANT EXPANSION FINANCING ALTERNATIVES

Darlene Gillum gave a brief update on the Water Treatment Plant (WTP) Expansion Project financing alternatives. US Bank has a "Non-revolver" financing product which allows the District to draw funds as needed against a pre-approved maximum loan amount during the construction. Once completed, the remaining open balance would be termed out. Interest and payments would be based on the total amount drawn. The interest rate quoted is lower than the interest rate on the CSDA Finance Corp Lease Buy-back product; however, it is a variable rate versus a fixed rate on the Lease Buy-back. Also, US Bank is only willing to offer a 7 year term versus the 20 year term offered by CSDA Finance Corporation.

Staff is still working with the Wells Fargo representative to obtain information on their line of credit program.

A full comparison of financing alternatives will be presented at the November Finance Committee and brought to the Board at the November meeting, which will allow all Directors to be involved in the selection of the financing product for the WTP expansion.

15. APPROVE GEOTECHNICAL ENGINEERING STUDY PROPOSAL

Paul Siebensohn gave a brief summary of the recommendation to approve the proposal from Youngdahl Consulting Group, Inc. for Geotechnical Engineering Study for the Water Treatment Plant Expansion Project.

Motion/Gumbinger to approve the proposal from Youngdahl Consulting Group, Inc. for Geotechnical Engineering Study for the Water Treatment Plant Expansion Project, in an amount not to exceed \$2,600. Funding to come from Water Replacement Reserves. **Second/Martel. Ayes: Pasek, Gumbinger and Martel. Noes: None. Absent: Belton and Ferraro.**

16. NOMINATIONS FOR SELECTION OF DISTRICT COMMISSIONER AND SELECTION OF ALTERNATE DISTRICT COMMISSIONER FOR THE LOCAL AGENCY FORMATION COMMISSION (LAFCo)

President Pasek recommended Gay Jones for District Commissioner. By consensus, the Board agreed.

17. REVIEW AND SELECT CONFERENCE/EDUCATION OPPORTUNITIES

Director Gumbinger will be attending the CSDA Special District Leadership Academy in November 2013.

18. MEETING DATES/TIMES

No changes.

19. COMMENTS/SUGGESTIONS – BOARD MEMBERS AND STAFF

Director Martel stated he will be sending out a letter in the future sharing his personal opinion/views regarding the District and the Board of Directors.

Director Gumbinger asked how the security fees the developers pay will be used. Darlene stated that it is outlined in the FSA, once it is approved. Director Martel stated he has some suggestions on how to run the Security Department and commented on how Security only reports crimes but does not solve any.

Director Martel commented on his being pulled over by a Game Warden and felt that they should not be allowed to enforce the vehicle code.

President Pasek asked about the status of the surveillance plan. Ed stated that the surveillance camera plan is going to Joint Security Committee, Security Committee, and then the Board in November.

Ed Crouse stated that at the October 8, 2013 Presidents meeting, items discussed included: North Gate update, RMCC membership update, new signage, recycled water standards, water conservation, and RMA having some water audits done.

Director Martel asked about the delinquency accounts. Darlene stated that Elk Grove Bilby paid in full to the District and that the remaining delinquencies were sent to the County for collection and the County will be paying the District.

20. ADJOURNMENT

Motion/Gumbinger to adjourn at 6:22 p.m. **Second/Martel. Ayes: Pasek, Gumbinger, and Martel. Noes: None. Absent: Belton and Ferraro.**

Respectfully submitted,

Suzanne Lindenfeld
District Secretary

DRAFT

RANCHO MURIETA COMMUNITY SERVICES DISTRICT

Board of Directors Special Meeting

MINUTES

October 25, 2013

9:00 a.m. Closed Session * 10:00 a.m. Open Session

1. CALL TO ORDER/ROLL CALL

President Gerald Pasek called the regular meeting of the Board of Directors of Rancho Murieta Community Services District to order at 9:00 a.m. in the District meeting room, 15160 Jackson Road, Rancho Murieta. Directors present were Gerald Pasek, Roberta Belton, Betty Ferraro, Paul Gumbinger, and Michael Martel. Also present were Edward R. Crouse, General Manager; Darlene Gillum, Assistant General Manager; Greg Remson, Security Chief; Paul Siebensohn, Director of Field Operations; and Suzanne Lindenfeld, District Secretary.

2. ADOPT AGENDA

Motion/Gumbinger to adopt the agenda. **Second/Martel. Ayes: Pasek, Belton, Ferraro, Gumbinger, and Martel. Noes: None.**

3. COMMENTS FROM THE PUBLIC

President Pasek stated that this will be carried over to after the Closed Session.

4. BOARD ADJOURNED TO CLOSED SESSION AT 4:03 P.M. TO DISCUSS THE FOLLOWING ITEMS:

Under Government Code section 54956.8: Conference with Real Property Negotiators - Real Property APN 128-0080-067; APN 128-0080-068; APN 128-0080-069; APN 128-0080-076; and APN 128-0100-029. Real Property Agency Negotiator: Edward R. Crouse, General Manager. Negotiating Party: CSGF Rancho Murieta, LLC, BBC Murieta Land, LLC, Murieta Retreats, LLC, PCCP CSGF RB PORTFOLIO, LLC. Under Negotiation: Price and Terms.

Conference with Legal Counsel – Anticipated Litigation. Initiation of litigation pursuant to Government Code Section 54956.9(c): (One Potential Case).

Conference with Legal Counsel – Anticipated Litigation. Significant Exposure to Litigation Pursuant to 54956.9(b): (One Potential Case).

The Board reconvened to Open Session at 10:12 a.m. and reported the following:

Under Government Code section 54956.8: Conference with Real Property Negotiators - Real Property APN 128-0080-067; APN 128-0080-068; APN 128-0080-069; APN 128-0080-076; and APN 128-0100-029. Real Property Agency Negotiator: Edward R. Crouse, General Manager. Negotiating Party: CSGF Rancho Murieta, LLC, BBC Murieta Land, LLC, Murieta Retreats, LLC, PCCP CSGF RB PORTFOLIO, LLC. Under Negotiation: Price and Terms. Nothing to report.

Conference with Legal Counsel – Anticipated Litigation. Initiation of litigation pursuant to Government Code Section 54956.9(c): (One Potential Case). Nothing to report.

Conference with Legal Counsel – Anticipated Litigation. Significant Exposure to Litigation Pursuant to 54956.9(b): (One Potential Case). Nothing to report.

5. FINAL REVIEW OF 670 FINANCING AND SERVICES AGREEMENT

Jonathan Hobbs, District General Counsel, reported that the FSA was presented to the Board for review and approval. The Board has asked staff and legal counsel to go back and double check some of the numbers and confirm some of the data. Therefore, Mr. Hobbs requested the item be put over to a date to be determined.

Motion/Belton that the Board put over a decision on the FSA as presented today to a future date when all data requested is available. **Second/Gumbinger.**

Mr. Hobbs stated that before the Board votes, the public should be allowed to comment.

John Sullivan asked if there was an estimate of when it will be coming back to the Board. President Pasek stated the item will be brought to the Board once all the data is available.

Ayes: Pasek, Belton, Ferraro, Gumbinger, and Martel. Noes: None.

6. COMMENTS/SUGGESTIONS – BOARD MEMBERS AND STAFF

Ed Crouse stated that Paul Siebensohn will be touring the Yuba City Water Treatment Plant scheduled for Tuesday, October 29, 2013. Ed also stated that Paul Siebensohn may be able to arrange a tour of the Main Lift North project if anyone is interested in seeing some of the work being done.

Director Martel stated that he liked the work that staff had done on the FSA. He also stated that he reported a possible violation to District staff and they are looking into it. As a Board member, Director Martel stated that as a Director, he should get a report back on this matter.

Director Belton reminded everyone to be careful with the kids out next Thursday (Halloween) and that the time change goes into effect next weekend.

Director Ferraro commented on her attendance at the California Special Districts Association Annual Conference she attended. A lot of what she attended covered suggestions about open communication, transparency, and communicating using laughter as a hook to get people to pay attention. Director Ferraro stated that she is looking to ensure that this community is not buying into something that they don't know about in the FSA.

7. ADJOURNMENT

Motion/Gumbinger to adjourn at 10:22 a.m. **Second/Belton. Ayes: Pasek, Belton, Ferraro, Gumbinger, and Martel. Noes: None.**

Respectfully submitted,

Suzanne Lindenfeld, District Secretary

MEMORANDUM

Date: November 1, 2013
To: Board of Directors
From: Communication & Technology Committee Staff
Subject: November 1, 2013 Communication & Technology Committee Meeting

Director Ferraro called the meeting to order at 9:00 a.m. Present were Directors Ferraro and Martel. Present from District staff were Edward Crouse, General Manager; Darlene Gillum, Assistant General Manager; Greg Remson, Security Chief; Paul Siebensohn, Director of Field Operations; and Suzanne Lindenfeld, District Secretary.

COMMENTS FROM THE PUBLIC

None.

PUBLIC OUTREACH

Water Reduction Communications to Residents

Darlene Gillum stated that this is still on the radar screen. The top 10% letters are scheduled to go out early 2014. At that time, we will do a database query to see if anyone dropped their use 10 or 20 percent and target a thank you letter to them.

Added Line to Billing Graph for 2020

At last month's Communications Committee the focus was changed to the large users, like Rancho Murieta Association and Rancho Murieta Country Club and for the District to work with the large users on conservation education and offering large-user water audits to them to identify suggested areas and ways to conserve.

Future Water Treatment Plant Communications

The design and schedule is still progressing, though in a state of flux. Based on where we are now, it is somewhat premature to talk about schedule, costs and rate impacts, especially since the full Board has not weighed in on the project.

A future targeted communication should come out in late December 2013 or early January 2014 with firm numbers and details.

NON-DIRECTOR PARTICIPATION ON COMMITTEES

Ed Crouse stated that at the January 31, 2013 District Board Goal Workshop, Director Gumbinger requested the Communications & Technology Committee discuss non-director participation on District Committees.

Current practice is that when an issue comes up which the Board feels could benefit from public participation, workshops are held and/or an Ad Hoc Committee is formed. Previous District Boards

have chosen not to add public members to standing committees due to the Board's perception of personal agendas, one issue topics and maintaining balanced public input.

Director Martel stated that President Pasek spoke to him about forming an ad hoc committee to discuss security issues and develop an overall security plan. **This item will be on the November 20, 2013 Board of Directors meeting agenda.**

DIRECTOR PERSONAL COMMENTS

Ed Crouse stated that at the October 4, 2013, Communications & Technology Committee meeting, Director Martel asked for a legal opinion and direction regarding his using District letterhead to convey his personal opinion to the public regarding actions of the Board and District staff when his opinion differs from the Board's decision.

Jonathan Hobbs', District General Counsel, opinion is that use of District letterhead to express a view that varies from that of the majority of the Board is a decision for the Board. District letterhead is property of the District, and the Board may authorize or restrict its use. The Board has already addressed this point by District Policy 2012-01 and the recently adopted Board Guidelines.

Director Martel stated that his intent is to ensure his opinion/position on Board actions is fully expressed to the public. **This item will be on the November 20, 2013 Board of Directors meeting agenda.**

DIRECTOR & STAFF COMMENTS/SUGGESTIONS

Chief Remson stated that Halloween night was pretty quiet.

Paul Siebensohn stated he will be updating the public notice regarding the Main Lift North bypass once the schedule has been confirmed.

Ed Crouse stated that President Pasek did speak to him about the recent security concerns but did not mention wanting an ad hoc committee. Director Martel stated that he believes President Pasek is getting frustrated with how long the camera issue is taking. Director Martel feels each entity having a standalone system is not a good idea. Director Ferraro agreed.

Director Martel commented on the need to look at ways to prevent crime from occurring. Chief Remson stated that Security can suggest things to do but cannot make anyone do them.

Director Martel commented on developing a policy regarding reviewing information prior to releasing information to the public and/or media to be sure the facts are correct.

ADJOURNMENT

The meeting was adjourned at 9:48 a.m.

MEMORANDUM

Date: November 6, 2013
To: Board of Directors
From: Personnel Committee Staff
Subject: November 6, 2013 Personnel Committee Meeting

Director Ferraro called the meeting to order at 9:03 a.m. Present were Directors Ferraro and Gumbinger. Present from District staff were Edward R. Crouse, General Manager; Darlene Gillum, Assistant General Manager; Greg Remson, Security Chief; and Suzanne Lindenfeld, District Secretary.

COMMENTS FROM THE PUBLIC

None.

UPDATES

Employee Relations

Chief Remson reported that the new Patrol Officer is scheduled to begin in about two (2) weeks.

Darlene Gillum stated that Susan Spalding's last day is Friday, November 8, 2013. She has accepted a job with Sacramento County.

360 EVALUATION SURVEY QUESTIONS FINAL REPORT

Darlene Gillum gave a brief summary of the Koff & Associates 360 Performance Evaluation Report. Directors Ferraro and Gumbinger stated that they would like more information regarding how the District is responding to the results and Koff findings.

Ed Crouse stated that he met with each manager individually to discuss their results. Each manager is to submit an improvement plan for themselves and their staff. A District-wide action plan will be presented at the next Personnel Committee meeting.

REVIEW JOB DESCRIPTIONS

Darlene Gillum gave a brief summary of the proposed changes to the organizational chart. These changes will become effect once the job descriptions have been adopted by the Board. The Committee suggested the Assistant General Manager and Director of Administration should be combined on the Organizational Chart.

Director Gumbinger requested that staff research if the title should be Comptroller or Controller. A discussion followed. With the few minor changes, **this item will be on the November 20, 2013 Board of Directors meeting agenda.**

DIRECTORS' & STAFF COMMENTS/SUGGESTIONS

Director Gumbinger stated that he will be on vacation from November 30 through December 16, 2013.

ADJOURNMENT

The meeting was adjourned at 9:51 a.m.

DRAFT

MEMORANDUM

Date: November 7, 2013
To: Board of Directors
From: Improvements Committee Staff
Subject: November 7, 2013 Committee Meeting Minutes

1. CALL TO ORDER

Director Pasek called the meeting to order at 8:30 a.m. Present were Directors Pasek and Gumbinger. Present from District staff were Edward Crouse, General Manager; Darlene Gillum, Assistant General Manager; and Suzanne Lindenfeld, District Secretary.

2. COMMENTS FROM THE PUBLIC

None.

3. UPDATES

Augmentation Well

Dunn Environmental submitted a Draft Technical Memorandum for review and comment. Staff provided comments and we are now waiting on the final memo, which will be available for the December Improvements Committee meeting.

Hotel Water Service Agreement

Ed Crouse reported that there is no change from last month as to formal approval and execution; although from recent discussions with John Sullivan, it appears the Hotel Service Agreement conditions will be rolled into a new fee and service agreement for all lands controlled and/or owned by John Sullivan and his partners.

The County's peer review was completed and submitted to the County last month. We have yet to hear back from the County on the final outcome and whether the County is moving forward with changes to the Hotel's conditions of approval to allow for the interim will serves.

Recycled Water Feasibility Study – CDPH Meeting

Ed Crouse reported that our Letter of Understanding from our last meeting with California Department of Public Health (CDPH) has been submitted but we have not heard back on their concurrence. Staff will be following up with CDPH as a result.

Recycled Standards/Title 22 Report/Master Recycled Water Permit Application

The Title 22 report is part of this month's Improvements Committee agenda for review and approval at the November Board meeting.

Kevin Kennedy, AECOM, is moving forward with our anti-degradation analysis based on the State's General Permit for Recycled Water Irrigation and that permit's guidelines for the analysis.

670 Financing and Services Agreement

Last week, Jon Hobbs prepared language revisions suggested by the Board which were forwarded to Les Hock for the group's review. We have not heard back yet but hope to have a response by the November Board meeting.

4. WATER TREATMENT PLANT EXPANSION PROJECT

Review CEQA IS/MND

Ed Crouse reported that HDR is completing the IS/MND although the delivery has slipped a bit. We expect the final soon so we can send it to the State Clearinghouse for distribution and our 30 day statutory review period.

Design Update

HDR is currently incorporating the GE membrane design in to their plans and they continue to move forward on other design elements.

Roebbelen is preparing the sub prequalification documents which should go out mid November.

SMUD Application Fee

The application for an upgraded and larger service was submitted to SMUD last week. No word back yet on SMUD's schedule.

SAQMD Generator Fee

Ed gave a brief summary of the recommendation to approve the permit fees to the Sacramento Air Quality Management District for a standby diesel generator. After a discussion, the Committee recommended the item go to the Board for approval. **This item will be on the November 20, 2013 Board meeting agenda.**

5. REVIEW DRAFT TITLE 22 ENGINEERING REPORT

Ed gave a brief summary of the Draft Title 22 Engineering Report prepared by Kevin Kennedy, AECOM. After a discussion, the Committee recommended the item go to the Board for approval. **This item will be on the November 20, 2013 Board meeting agenda.**

6. DISCUSS NEW NORTH GATE FUNDING REQUEST BY RANCHO MURIETA ASSOCIATION

Ed gave a brief update on the New North Gate funding request from Rancho Murieta Association (RMA). Given recent discussions between the RMA North Gate Committee and John Sullivan and his development team on their vision of the new North Gate design concepts, our discussions with RMA are on hold until a new plan is developed and construction costs are estimated.

DIRECTORS' & STAFF COMMENTS/SUGGESTIONS

Suzanne gave a brief summary of the new conservation items the District will be giving away. These include a shower timer, a moisture meter, and an outdoor water conservation kit.

7. ADJOURNMENT

The meeting was adjourned at 9:12 a.m.

MEMORANDUM

Date: November 7, 2013
To: Board of Directors
From: Finance Committee Staff
Subject: November 7, 2013 Finance Committee Meeting

1. CALL TO ORDER

Director Pasek called the meeting to order at 9:30 a.m. Present were Directors Pasek and Gumbinger. Present from District staff were Edward Crouse, General Manager; Darlene Gillum, Assistant General Manager; and Suzanne Lindenfeld, District Secretary. Director Belton arrived at 9:58 a.m. and Director Gumbinger left at 9:58 a.m.

2. COMMENTS FROM THE PUBLIC

None.

4. CFD #1 REFUND REQUEST – DONALD KURTZ (taken out of order)

Donald Kurtz stated that he had pre-paid the Mello Roos several years ago. Since the bonds were called early, Mr. Kurtz would like the District or the CFD to give him a refund of approximately \$1,400, which is an equivalent amount that the residents received when the bonds were paid off. Darlene Gillum stated that she is waiting to get a legal opinion back on Mr. Kurtz's request.

3. UPDATES

Water Treatment Plant Expansion Financing Alternatives

Darlene Gillum gave a brief summary of the quotes from California Special Districts Association (CSDA) Finance Corporation and US Bank for a \$3,000,000 principal loan. Wells Fargo left a message on Tuesday stating they are interested in providing a quote but are not able to meet our Committee deadline. They will be providing their quote sometime next week. Director Pasek requested staff make a recommendation on which option along with the reasoning behind it at the November Board meeting. **This item will be on the November 20, 2013 Board meeting agenda.**

Financing and Services Agreement

Last week, Jon Hobbs prepared language revisions suggested by the Board which were forwarded to Les Hock for the group's review. We have not heard back yet but hope to have a response by the November Board meeting.

5. TRANSFERS TO RESERVE FUNDS

Darlene Gillum gave a brief summary of the recommended transfers to reserve funds. After a short discussion, the Committee recommended the item go to the Board for approval. **This item will be on the November 20, 2013 Board meeting agenda.**

6. DIRECTORS' & STAFF COMMENTS/SUGGESTIONS

Director Belton suggested staff look into advertising on hot beverage cup sleeves.

7. ADJOURNMENT

The meeting was adjourned at 10:06 a.m.

DRAFT

MEMORANDUM

Date: November 7, 2013
To: Board of Directors
From: Security Committee Staff
Subject: November 7, 2013 Security Committee Meeting

1. CALL TO ORDER

Director Belton called the meeting to order at 10:02 a.m. Present were Directors Belton and Pasek. Present from District staff were Edward R. Crouse, General Manager; Darlene Gillum, Assistant General Manager; Greg Remson, Security Chief; and Suzanne Lindenfeld, District Secretary. Director Martel was absent.

2. COMMENTS FROM THE PUBLIC

None.

3. MONTHLY UPDATES

Operations

Halloween was mostly quiet. A few smashed pumpkins and a report of a speeding vehicle on Celebrar Street. When the complainant tried to wave down the vehicle so it would slow down, he hit the side mirror, breaking off the mirror. He was not injured.

There were multiple thefts from the Mini-Storage on Cantova Way and attempted thefts across Cantova Way at the Murieta Village Mini-Storage. Security Patrol Officers provided extra patrol in the area, scheduling was adjusted for extended coverage, Sacramento Sheriff's Department (SSD) was requested for assistance, crime prevention suggestions were given to the owners, and possible suspect information was provided. There was no forced entry through the gates or fence. The Mini-Storage has installed surveillance cameras and changed the gate access system.

Incidents of Note

Chief Remson gave a brief overview of the incidents of note for the month of October 2013.

RMA Citations/Admonishments

Chief Remson reported on the following Rancho Murieta Association (RMA) rule violation citations for the month of October, which included 54 open garage doors, 22 loose/off leash dogs, and 11 barking dogs. RMA rule violation admonishments and/or complaints for the month of October included 48 driveway parking, 33 stop sign, and 23 overnight street parking.

RMA Compliance/Grievance/Safety Committee Meeting

The meeting was held on October 7, 2013. There was one (1) appearance by neighbors complaining about chronic barking dogs, and (1) appearance regarding parking.

Joint Security Committee Meeting

The Joint Security Committee met on November 1, 2013. Items on the agenda were Security Surveillance Cameras and Golf Cart Safety.

James L. Noller Safety Center

The Safety Center has been open most Mondays and Wednesdays from 10:00 a.m. to 2:00 p.m. VIPS Jacque Villa and Steve Lentz continue patrolling the District as another set of "eyes and ears".

The Safety Center is also available to all law enforcement officers for report writing, meal breaks and any other needs that arise.

Anyone who is interested in joining the VIPS program or would like information on the Neighborhood Watch program can contact the VIPS at the Safety Center office at 354-8509.

New North Gate

At the October 31, 2013 New North Gate meeting, John Sullivan and his design team brought drawings with a new theme that they hope to incorporate into the new North Gate, hotel, and new development on the North side. Some of the ideas had already been discussed and modified by the Committee and that information was sent back to John Sullivan's group for incorporation.

Beach Access/PTF Gates

District Patrol Officers continue to open the gate at dawn and close it at dusk. Calls for service continue to be rare. Due to the occasional driver who drives around the Bass Lake PTF gate, RMA has requested that Security lock the gate located on the east end of Bass Lake. Once RMA has installed reflective warning signs on both sides of the gates, Patrol will begin locking and unlocking the gate at the same time the beach access gate is locked and unlocked.

4. FINAL SECURITY SURVEILLANCE CAMERA PLAN

Chief Remson gave a brief summary of the District's Security Surveillance Camera Plan. The next step for the District is to finalize the Surveillance Camera Implementation, Integration and Expansion Plan, determine costs to implement a viewing system, get Board approval for the expenditures, and install the viewing system. After a discussion, the Committee recommended the Plan go to the Board for approval. **This item will be on the November 20, 2013 Board meeting agenda.**

Director Belton left at 10:42 a.m.

6. DIRECTOR & STAFF COMMENTS

None.

7. ADJOURNMENT

The meeting adjourned at 10:50 a.m.

MEMORANDUM

Date: November 12, 2013
 To: Board of Directors
 From: Darlene Gillum, Assistant General Manager
 Subject: Bills Paid Listing

Enclosed is the Bills Paid Listing Report for **October 2013**. Please feel free to call me before the Board meeting regarding any questions you may have relating to this report. This information is provided to the Board to assist in answering possible questions regarding large expenditures.

The following major expense items (excluding payroll related items) are listed *in order as they appear* on the Bills Paid Listing Report:

Vendor	Project/Purpose	Amount	Funding
California Waste Recovery Systems	Solid Waste Contract	\$45,433.45	Operating Expense
Golden State Risk Management Assoc	Workers Comp & Liability Premium – 2 Quarter	\$33,081.27	Operating Expense
NTU Technologies, Inc.	Chemicals	\$5,954.76	Operating Expense
SMUD	Service Application	\$5,000.00	Operating Expense (pending Reserve Expenditure approval)
HDR Engineering, Inc	MLN Wet Well Rehab WTP1 Expansion Design	\$4,422.45 <u>\$20,464.62</u> \$24,887.07	Reserve Expenditure LOC Demand
JB Bostick	Multiple Street Repairs	\$8,925.00	Operating Expense
Prodigy Electric	Multiple Electric Repairs	\$8,054.68	Operating Expense
SMUD	Monthly Electric	\$27,590.62	Operating Expense
State of California	Water System Fees (2012-2013)	\$21,702.53	Operating Expense

Rancho Murieta Community Services District
Bills Paid Listing for October 2013

Ck Number	Date	Vendor	Amount	Purpose
ACH	10/2/2013	US Postmaster	\$500.00	Postage
CM27143	10/3/2013	California Debt & Investment Advisory Comm.	\$375.00	Training
CM27144	10/3/2013	California Public Employees' Retirement Sys	\$34,013.91	Payroll
CM27145	10/3/2013	Guardian Life Insurance	\$4,828.55	Payroll
CM27146	10/3/2013	Vision Service Plan (CA)	\$431.70	Payroll
CM27147	10/11/2013	A Leap Ahead IT	\$3,447.18	Monthly IT Services
CM27148	10/11/2013	A&D Automatic Gate and Access	\$510.00	North Gate Repair
CM27149	10/11/2013	Ace Hardware	\$275.76	Monthly Supplies
CM27150	10/11/2013	American Express	\$1,093.05	Monthly Bill
CM27151	10/11/2013	American Family Life Assurance Co.	\$590.24	Payroll
CM27152	10/11/2013	Aramark Uniform Services	\$215.63	Uniform Services - Water
CM27153	10/11/2013	ASR - Sacramento Uniform	\$292.61	Security Uniform
CM27154	10/11/2013	California Waste Recovery Systems	\$45,433.45	Solid Waste Monthly Contract
CM27155	10/11/2013	Caltronics Business Systems	\$576.72	Ink Cartridges
CM27156	10/11/2013	Cell Energy Inc.	\$403.60	Batteries
CM27157	10/11/2013	Costco	\$970.02	Monthly Supplies
CM27158	10/11/2013	Dunn Environmental, Inc.	\$2,322.20	Test Well Drilling
CM27159	10/11/2013	Employment Development Department	\$2,522.12	Payroll
CM27160	10/11/2013	Express Office Products, Inc.	\$305.18	Office Supplies
CM27161	10/11/2013	Folsom Lake Fleet Services	\$1,753.14	Service #520 & #809
CM27162	10/11/2013	Golden State Flow Measurement	\$2,991.75	Water Meters
CM27163	10/11/2013	GSRMA	\$33,081.27	Workers Comp & Liability 2nd Quarter
CM27164	10/11/2013	Groeniger & Company	\$2,449.88	Maintenance & Repair Supplies
CM27165	10/11/2013	Hach Company	\$960.11	Maintenance & Repair Supplies
CM27166	10/11/2013	HDR Engineering, Inc	\$396.03	MLN Wet Well Rehabilitation
CM27167	10/11/2013	Konecranes Inc.	\$395.00	Quarterly Crane Inspection
CM27168	10/11/2013	Legal Shield	\$116.32	Payroll
CM27169	10/11/2013	Nationwide Retirement Solution	\$1,737.23	Payroll
CM27170	10/11/2013	NTU Technologies, Inc.	\$5,954.76	Chemicals
CM27171	10/11/2013	Operating Engineers Local Union No. 3	\$477.18	Payroll
CM27172	10/11/2013	P. E. R. S.	\$12,778.17	Payroll
CM27173	10/11/2013	PERS Long Term Care Program	\$48.10	Payroll
CM27174	10/11/2013	Romo Landscaping	\$385.00	Landscaping
CM27175	10/11/2013	Sierra Office Supplies	\$859.40	Office Supplies
CM27176	10/11/2013	Sprint	\$672.11	Monthly Cell Phone
CM27177	10/11/2013	Syneco Systems Inc.,	\$3,775.20	Odor Scrubber Media
CM27178	10/11/2013	TASC	\$172.69	Payroll
CM27179	10/11/2013	TelePacific Communications	\$494.34	Monthly Phone Bill
CM27180	10/11/2013	U.S. Bank Corp. Payment System	\$3,835.11	Monthly Gasoline
CM27181	10/11/2013	USA Blue Book	\$2,213.83	Maintenance & Repair Supplies
CM27182	10/11/2013	W.W. Grainger Inc.	\$858.50	Safety Items

Rancho Murieta Community Services District
Bills Paid Listing for October 2013

Ck Number	Date	Vendor	Amount	Purpose
ACH	10/15/2013	EFTPS	\$9,466.30	Bi-Weekly Payroll Taxes
CM27183	10/16/2013	James Pryor	\$300.00	Toilet Rebate
CM27184	10/23/2013	S. M. U. D.	\$5,000.00	Service Application
CM27185	10/25/2013	A&D Automatic Gate and Access	\$4,489.53	Repair Gate Operator
CM27186	10/25/2013	Action Cleaning Systems	\$1,172.00	Monthly Cleaning Service
CM27187	10/25/2013	American Family Life Assurance Co.	\$590.24	Payroll
CM27188	10/25/2013	ARC	\$86.83	Water Master Plan Prints
CM27189	10/25/2013	Applications By Design, Inc.	\$125.00	Security Data Backup
CM27190	10/25/2013	Aramark Uniform Services	\$393.89	Uniform Services - Water
CM27191	10/25/2013	AT&T	\$840.67	Monthly Phone Bill
CM27192	10/25/2013	California Laboratory Services	\$2,018.80	Lab Tests - Monthly and Augmentation Well
CM27193	10/25/2013	Caltronics Business Systems	\$1,919.30	Monthly Admin Copier
CM27194	10/25/2013	Carrillo Enterprises	\$3,836.70	Multiple Repairs
CM27195	10/25/2013	DrawingBoard Printing	\$126.25	Office Supplies
CM27196	10/25/2013	Employment Development Department	\$3,252.85	Payroll
CM27197	10/25/2013	Eurofins Eaton Analytical, Inc.	\$250.00	MIB & Geosmin Analysis
CM27198	10/25/2013	Express Office Products, Inc.	\$491.85	Office Supplies
CM27199	10/25/2013	Ford Motor Credit Company LLC	\$234.78	Security Vehicle Lease
CM27200	10/25/2013	G4S Secure Solutions (USA) Inc.	\$600.00	Security Officers
CM27201	10/25/2013	Golden State Flow Measurement	\$325.08	Gasket & Chaser
CM27202	10/25/2013	HDR Engineering, Inc	\$24,887.07	MLN Wet Well Rehab, WTP1 Expansion Design
CM27203	10/25/2013	Howe It's Done	\$262.14	Board Meeting Dinner
CM27204	10/25/2013	J B Bostick Company	\$8,925.00	Multiple Repairs
CM27205	10/25/2013	Koff & Associates, Inc.	\$3,780.00	360 Degree Eval Survey
CM27206	10/25/2013	Kronick Moskovitz Tiedemann & Girard	\$2,098.50	Legal Consulting
CM27207	10/25/2013	Legal Shield	\$116.32	Payroll
CM27208	10/25/2013	Nationwide Retirement Solution	\$1,663.23	Payroll
CM27209	10/25/2013	Operating Engineers Local Union No. 3	\$520.56	Payroll
CM27210	10/25/2013	P. E. R. S.	\$13,750.34	Payroll
CM27211	10/25/2013	PERS Long Term Care Program	\$48.10	Payroll
CM27212	10/25/2013	Pitney Bowes	\$698.32	Postage Machine Lease
CM27213	10/25/2013	Prodigy Electric	\$8,054.68	Multiple Repairs
CM27214	10/25/2013	Public Agency Retirement Services	\$300.00	Trust Admin Fees
CM27215	10/25/2013	Ramos Environmental Services	\$55.00	Removal of Waste Oil
CM27216	10/25/2013	Rancho Murieta Association	\$284.47	Landscaping/Cable/Internet
CM27217	10/25/2013	Romo Landscaping	\$385.00	Landscaping
CM27218	10/25/2013	Rotorooter Service & Plumbing	\$1,087.32	South Gate Water Heater
CM27219	10/25/2013	S. M. U. D.	\$27,590.62	Monthly Electric
CM27220	10/25/2013	Sierra Office Supplies	\$376.92	Office Supplies
CM27221	10/25/2013	Socius	\$3,529.80	Annual Software Maintenance Renewal
CM27222	10/25/2013	State of California	\$21,702.53	Water System Fees (2012 - 2013)

**Rancho Murieta Community Services District
Bills Paid Listing for October 2013**

Ck Number	Date	Vendor	Amount	Purpose
		CFD#1 Bank of America Checking		
CM2699	10/11/2013	CoreLogic Solutions, LLC.	\$190.00	CFD#1 Admin Fees
CM2700	10/11/2013	US Bank Corporate Trust	\$174.99	CFD#1 Admin Fees
		TOTAL	\$364.99	
		EL DORADO PAYROLL		
Payroll (El Dorado)				
Checks: # CM11075 to CM11089 and Direct Deposits: DD06733 to DD06791			\$ 108,272.39	Payroll
ACH	10/31/2013	National Payment Corp	\$137.24	Payroll
		TOTAL	\$108,409.63	

MEMORANDUM

Date: November 13, 2013
To: Board of Directors
From: Edward R. Crouse, General Manager
Subject: General Manager's Report

The following are highlights since our last Board Meeting.

Employee Relations

Debby worked with staff on health care changes to enrollment for the PERS January 1, 2014 roll out of new providers and changes to premiums.

In August 2013, the 360-Degree Performance Evaluation survey developed by Koff & Associates was made available via Survey Monkey to all District employees to provide them the opportunity to provide performance evaluation ratings on any or all District managers and supervisors. After resolving technical issues, the survey period closed September 20, 2013. A total of 40 electronic surveys were submitted, including 3 copies that provided no responses. Three (3) hard copy surveys were also submitted. Scores for criteria rankings were tabulated for each competency. Open-ended feedback was compiled, reviewed, and a summarized report provided.

The report incorporates a summary of the evaluation process, including competencies, rating criteria, and survey methodology. The report presented is a high-level summary of the overall strengths and weaknesses of District managers and supervisors' performance. Due to the confidential nature of personnel performance evaluations, the summaries of individual managers and supervisors' evaluation results were provided to me and, based on legal opinion, will not be released in public forum. The individual evaluations will be discussed between the employee and the employee's manager to identify constructive plans of action to improve the employee's area(s) needing improvement. Managers will submit an improvement plan for themselves and their staff, which will be summarized for the next Personnel Committee meeting.

Finance/IT

Debby is completing new PERS medical enrollment processing for the new plans and employee share calculations. She is working with PERS on our new medical employer and employee share certifications for payroll purposes.

Darlene finalized our State Controller's reports for District operations and compensation.

Security

Greg has tendered an offer, which was accepted, to fill our vacant Patrol Officer position. The new Patrol Officer will begin training on November 18, 2013.

At the October 31, 2013 New North Gate meeting, John Sullivan and his design team brought new drawings which they hope to incorporate into the new North Gate, hotel, and new development on the North side. Some of the ideas have been discussed and modified by the Committee and sent back to John Sullivan's group for incorporation.

Water

Water production again dropped from last month, 10% this month vs. 30 % last month. Production is at 1.8 mgd, which is within capacity of WTP 2 (2.0 mgd). This is normal, and it is likely a trigger month when we can take WTP 1 out of service for the expansion project next year. However, Paul keeps both plants running, producing 1.8 mgd.

Wastewater

As reported last month, we shut down the reclamation plant in early October as we had little to no available storage to produce recycled water. Staff is beginning routine maintenance planning and earmarking larger projects for late this spring.

Main Lift North Rehabilitation Project is moving along. Structural steel for the crane has been installed and as well as wet well concrete cleaning and prepping completed. In the process, we encountered groundwater, which resulted in additional preventative measures to allow for concrete repairs and coating. Moving forward, we may need more extensive groundwater pumping equipment to reduce localized groundwater around the pump station to allow continued rehab. In addition, now that groundwater was evidenced, we may need to inject concrete slurry type mixtures to ensure groundwater does not seep into the wet wells.

Drainage

Paul's crews continue preventative maintenance, cleaning of ditches and drainage facilities for the winter season.

Rob McLeod and James Colas attended a recent stakeholder meeting of statewide MS4 permittees on new storm drainage permit requirements. The meeting was one of several outreach efforts by the State to get permittees input on new requirements, which are planned to be effective 2014-15.

Solid Waste

Nothing new to report on the collections side. Thanksgiving Day collection will begin at 6:00 a.m.

Engineering

Augmentation Well

Dunn Environmental submitted a Draft Technical Memorandum for review and comment. Staff provided comments and we are now waiting on the final memo, which will be available for the December Improvements Committee meeting.

Hotel Water Service Agreement

No change from last month as to formal approval and execution although from recent discussions with John Sullivan, it appears the Hotel Service Agreement conditions will be rolled into a new finance and service agreement for all lands controlled and/or owned by John and his partners.

The County's peer review has been completed and submitted to the County last month. We have yet to hear back on the outcome and whether the County is moving forward with changes to the Hotel's conditions of approval to allow for the interim will serves.

Recycled Water Feasibility Study – CDPH Meeting

We submitted our Letter of Understanding from our last meeting with California Department of Public Health (CDPH) and have not heard back on their concurrence. Staff will be following up with CDPH as a result.

Recycled Standards/Title 22 Report/Master Recycled Water Permit Application

The Title 22 report is part of this month's Board agenda for review and approval.

Kevin Kennedy, AECOM, is moving forward with our anti-degradation analysis based on the State's General Permit for Recycled Water Irrigation and that permit's guidelines for the analysis.

670 Financing and Services Agreement

Last week, Jon Hobbs prepared language revisions suggested by the Board, which have been forwarded to Les Hock for the group's review. We have not heard back yet but hope to have a response by the November Board meeting.

Airport Hanger Expansion Project

Staff is reviewing site and utility plans for the planned hanger expansion, of two 20,000 square foot hangers. Water and sewer lines will be extended to the hangers but not hooked up, as the hangers are shells waiting for tenant improvements.

As part of our plan review, we will be addressing long-term fire protection piping and metering changes and domestic service metering changes. We will also be addressing an unapproved service connection from a fire hydrant line to a small vegetable garden.

Conservation

November is **Turn Off Sprinklers** month. We are offering toilet, clothes washer, water pressure reducing valve, and water heater recirculating pump rebates. The District is also giving away a variety of water conservation items, which includes an outdoor water conservation kit, a ladybug moisture meter, a shower timer, a garden kneeling pad, and a sprinkler screwdriver.

I met with Greg Vorster concerning moving forward with RMA and District coordination on long-term conservation measures, particularly related to new development and existing landscape model projects.

MEMORANDUM

Date: November 12, 2013
 To: Board of Directors
 From: Darlene Gillum, Assistant General Manager
 Subject: Administration/Financial Reports

Enclosed is a combined financial summary report for **October 2013**. Following are highlights from various internal financial reports. Please feel free to call me before the Board meeting regarding any questions you may have relating to these reports.

This information is provided to the Board to assist in answering possible questions regarding under or over-budget items. In addition, other informational items of interest are included.

Water Consumption - Listed below are year-to-date water consumption numbers using weighted averages:

12 month rolling % increase		Jul	Aug	Sep	Oct	Nov	Dec	Jan	Feb	Mar	Apr	May	Jun
Residences	0.0	2,513	2,513	2,513	2,513								
Weighted average		Jul	Aug	Sep	Oct	Nov	Dec	Jan	Feb	Mar	Apr	May	Jun
Cubic Feet	2,779	3074	2996	2932	2114								
Gallons per day	693	766	747	731	527								
Planning Usage GPD	583												

Lock-Offs - For the month of October, there were 17 lock-offs.

Aging Report – Delinquent accounts total \$49,862 which is 9.3% of the total accounts receivable balance of \$536,682. Past due receivables, as a percent of total receivables, have decreased by 1.7% since September.

Summary of Reserve Accounts as of October 31, 2013 – The District’s reserve accounts have increased \$270,875, year to date, since July 1, 2013. The increase is due to the reserve amounts collected in the Water and Sewer base rates and interest earned. The District has expended \$144,380 of reserves since the beginning of the fiscal year, which started July 1, 2013. The total amount of reserves held by the District as of October 30, 2013 is \$8,906,427. Please see the Reserve Fund Balances table below for information by specific reserve account.

Reserve Fund Balances

<i>Reserve Descriptions</i>	<i>Fiscal Yr Beg Balance July 1, 2013</i>	<i>YTD Collected & Interest Earned</i>	<i>YTD Spent</i>	<i>Period End Balance Oct 31, 2013</i>
Water Capital Replacement (200-2505)	2,682,621	71,406	(52,632)	2,701,395
Sewer Capital Replacement (250-2505)	2,869,146	96,963	(38,825)	2,927,284
Drainage Capital Replacement (260-2505)	26,834	13	(18,922)	7,925
Security Capital Replacement (500-2505)	51,315	31	(0)	51,346
Sewer Capital Improvement Connection (250-2500)	4,008	3	(0)	4,011
Capital Improvement (xxx-2510)	392,601	282	(0)	392,883
Water Supply Augmentation (200-2511)	2,448,725	1,558	(34,001)	2,416,282
Water Debt Service Reserves (200-2512)	139,260	65,898	(0)	205,158
Sewer Debt Service Reserves (250-2512)	163,116	34,720	(0)	197,836
Rate Stabilization (200/250/500-2515)	2,306	2	(0)	2,308
Total Reserves	8,779,932	270,876	(144,380)	8,906,428

PARS GASB 45 Trust - The PARS GASB 45 Trust, which is the investment trust established to fund Other Post Employment Benefits, had the following returns:

Period ended August 31, 2013		
1-Month	3-Months	1-Year
-2.00%	-0.65%	9.31%

Financial Summary Report (year to date through October 31, 2013)

Revenues:

Water Charges, year-to-date, are **above** budget \$1,364 or .2%

Sewer Charges, year-to-date, are **below** budget \$172 or (0.0%)

Drainage Charges, year-to-date, are **below** budget \$172 or (0.3%)

Security Charges, year-to-date, are **below** budget \$86 or (0.0%)

Solid Waste Charges, year-to-date, are **below** budget \$136 or (0.1%)

Total Revenues, which includes other income, property taxes and interest income year-to-date, are **above** budget \$13,366 or 0.7% (\$12,081 of which is due to late charges and transfer fees exceeding budget projections). Year to date residential Water usage has exceeded budget projections by 1.2% and year to date commercial Water usage is below budget projections by (4.1%).

Expenses: Year-to-date total operating expenses are below budget \$147,771 or 8.1%. Year-to-date operational reserve expenditures total \$18,922. Operational reserve expenditures cover projects funded from reserves which are also recorded as operational expenses through the income statement as required by Generally Accepted Accounting Principles (GAAP).

Water Expenses, year-to-date, are **below budget \$46,567 or (9.1%), prior to reserve expenditures.** Wages are under budget due to the open Utility Worker position and the actual allocation variance between Water, Sewer and Drainage. Employer Costs are under budget due to the combination of the open Utility Worker position, Medical Opt Out contingency under-run and the variance between the actual allocation of labor charges between Water, Sewer and Drainage and the projected budget allocations. Chemicals, Taste & Odor Chemicals, Water Meters, Lab Tests, Permits, Equipment Rental and Other Direct Costs (which include Legal, IT Systems Maintenance, Vehicle Maintenance and Conservation) are the largest areas running below budget. Year-to-date \$0 of expenses have been incurred from reserves expenditures.

Sewer Expenses, year-to-date, are **below budget by \$52,552 or (15.0%), prior to reserve expenditures.** Areas running over budget are Chemicals and Lab Tests. Wages are under budget due to the open Utility Worker position and the actual allocation variance between Water, Sewer and Drainage. Employer Costs are under budget due to the combination of the open Utility Worker position, Medical Opt Out contingency under-run and the variance between the actual allocation of labor charges between Water, Sewer and Drainage and the projected budget allocations. Areas running below budget are Power, Maintenance & Repair, Permits, Training/Safety, Equipment Rental and Other Direct Costs (which includes Vehicle Maintenance, Vehicle Fuel, Legal and Consulting). Year-to-date \$0 of expenses have been incurred from reserves expenditures.

Drainage Expenses, year-to-date, are **below budget by \$3,057 or (6.89%).** Areas running over budget are Permits. Wages are over budget due to the combination of the open Utility Worker position and the actual allocation variance between Water, Sewer and Drainage. Employer Costs are over budget due to the combination of the open Utility Worker position, Medical Opt Out contingency under-run and the variance between the actual allocation of labor charges between Water, Sewer and Drainage and the projected budget allocations. Areas running below budget are Maintenance and Repair, Power, Chemicals and Other Direct Costs (which includes Consulting and Drainage Flood Work).

Security Expenses, year-to-date, are **below budget by \$38,823 or (11.5%).** Areas running over budget are Equipment Repairs, Vehicle Maintenance and Off Duty Sheriff. Wages and Employer Costs are running under budget due to the open Patrol Officer position and a Patrol Officer who was out on a Workers' Comp injury. Areas running below budget are Vehicle Fuel and Other (which includes Telephones, Barcodes, Vehicle Lease, Legal, and Training/Safety).

Solid Waste Expenses, year-to-date, are **below budget by \$11,467 or (5.6%).** The under-run is related to the Household Hazardous Waste Event budget of 50% of the bi-annual collection event. The budget is planned to collect 50% of the cost of the event every year while the event is planned to be held bi-annually.

General Expenses, year-to-date, are **above budget by \$4,693 or 1.3%**. The largest areas running over budget are Insurance (due to the increase in our appraised property value), Office Supplies (related to the purchase of the new billing statement stock), Community Communications (related to website updates/upgrades) and Other (which includes Copy Machine Maintenance, Memberships, Audit (due to a timing issue between actual and budget), and Consulting (related to the 360 Degree Evaluation Survey). Areas running below budget are Wages, Employer Cost, Director Meetings, Legal, and IT Systems Maintenance (which is related to timing between budget and actual expenditures for some annual maintenance renewals).

Net Income: Year-to-date unadjusted net income, before depreciation, is \$369,214. Net income/(Loss) adjusted for estimated depreciation expense of \$367,367 is \$1,847.

The YTD expected net operating income before depreciation, per the 2013-2014 budget, is \$226,999. The actual net operating income is \$161,137 higher than the budget expectation due to revenue running \$13,366 over budget and total operating expenses running under budget \$147,771.

Water Treatment Plant 1 (WTP1) Expansion and Upgrade Project

The table below is a summary of expenditures, through October 2013, related to the Water Treatment Plant Expansion and Upgrade Project:

WTP1 Expansion and Upgrade Project	Approved Amount	RMCS D	Letter of Credit	Developer	Total expended to date
WTP Design (HDR)	\$177,778.00		\$33,842.60		\$33,842.60
Construction Manager at Risk (Roebbelen)	\$49,049.00				
SMUD Application	\$5,000.00	\$5,000.00			\$5,000.00
CEQA (HDR)	\$46,292.00		\$2,689.24		\$2,689.24
Geotechnical Study (Youngdahl)	\$2,600.00	\$2,600.00			\$2,600.00
Total	<u>\$280,719.00</u>	<u>\$7,600.00</u>	<u>\$36,531.84</u>		<u>\$44,131.84</u>

Rancho Murieta Community Services District
Summary Budget Performance Report
YTD THROUGH OCTOBER 2013

	% of Total	Annual Budget	% of Total	YTD Budget	YTD Actuals	% of Total	YTD VARIANCE	
							Amount	%
REVENUES								
Water Charges	31.7%	\$1,775,230	37.6%	\$767,503	\$768,867	37.4%	\$1,364	0.2%
Sewer Charges	22.1%	1,237,740	20.2%	412,444	412,272	20.1%	(172)	0.0%
Drainage Charges	3.2%	180,430	2.9%	60,140	59,968	2.9%	(172)	(0.3%)
Security Charges	21.2%	1,185,510	19.4%	395,168	395,082	19.2%	(86)	0.0%
Solid Waste Charges	11.1%	621,072	10.1%	207,024	206,888	10.1%	(136)	(0.1%)
Other Income	1.7%	92,550	1.5%	30,274	42,674	2.1%	12,400	41.0%
Interest Earnings	0.0%	1,140	0.0%	301	469	0.0%	168	55.8%
Property Taxes	9.0%	502,800	8.2%	167,600	167,600	8.2%		0.0%
Total Revenues	100.0%	5,596,472	100.0%	2,040,454	2,053,820	100.0%	13,366	0.7%
OPERATING EXPENSES								
Water/Sewer/Drainage								
Wages	14.5%	809,730	13.6%	247,100	236,777	14.2%	(10,323)	(4.2%)
Employer Costs	6.9%	385,450	6.7%	120,801	115,807	7.0%	(4,994)	(4.1%)
Power	5.8%	325,510	6.2%	112,600	100,499	6.0%	(12,101)	(10.7%)
Chemicals	4.3%	240,200	5.9%	106,895	82,527	5.0%	(24,368)	(22.8%)
Maint & Repair	6.2%	345,470	6.0%	108,030	99,408	6.0%	(8,622)	(8.0%)
Meters/Boxes	1.0%	54,000	0.9%	16,500	9,906	0.6%	(6,594)	(40.0%)
Lab Tests	1.3%	74,250	1.2%	22,100	24,340	1.5%	2,240	10.1%
Permits	1.1%	64,300	1.7%	31,100	20,704	1.2%	(10,396)	(33.4%)
Training/Safety	0.4%	21,700	0.5%	8,750	4,482	0.3%	(4,268)	(48.8%)
Equipment Rental	0.8%	43,500	1.0%	18,350	10,290	0.6%	(8,060)	(43.9%)
Other	7.0%	394,010	6.1%	110,767	96,078	5.8%	(14,689)	(13.3%)
Subtotal Water/Sewer/Drainage	49.3%	2,758,120	49.8%	902,993	800,818	48.1%	(102,175)	(11.3%)
Security								
Wages	11.2%	625,100	10.4%	189,000	167,830	10.1%	(21,170)	(11.2%)
Employer Costs	6.7%	374,700	6.4%	116,300	100,776	6.1%	(15,524)	(13.3%)
Off Duty Sheriff Patrol	0.1%	6,000	0.1%	2,000	2,985	0.2%	985	49.3%
Other	1.7%	94,700	1.7%	30,334	27,221	1.6%	(3,113)	(10.3%)
Subtotal Security	19.7%	1,100,500	18.6%	337,634	298,812	17.9%	(38,822)	(11.5%)
Solid Waste								
CWRS Contract	9.7%	543,000	10.0%	181,000	181,560	10.9%	560	0.3%
Sacramento County Admin Fee	0.6%	34,680	0.6%	11,560	11,533	0.7%	(27)	(0.2%)
HHW Event	0.2%	12,000	0.7%	12,000		0.0%	(12,000)	(100.0%)
Subtotal Solid Waste	10.5%	589,680	11.3%	204,560	193,093	11.6%	(11,467)	(5.6%)
General / Admin								
Wages	9.5%	534,200	8.9%	161,100	158,997	9.5%	(2,103)	(1.3%)
Employer Costs	5.2%	292,300	5.1%	91,600	84,866	5.1%	(6,734)	(7.4%)
Insurance	0.8%	45,000	0.8%	15,004	21,537	1.3%	6,533	43.5%
Legal	0.4%	25,000	0.4%	8,000	3,507	0.2%	(4,493)	(56.2%)
Office Supplies	0.3%	19,200	0.4%	6,400	10,254	0.6%	3,854	60.2%
Director Meetings	0.3%	18,000	0.3%	6,008	4,500	0.3%	(1,508)	(25.1%)
Telephones	0.1%	4,620	0.1%	1,536	1,498	0.1%	(38)	(2.5%)
Information Systems	1.4%	79,000	2.4%	42,662	26,325	1.6%	(16,337)	(38.3%)
Community Communications	0.1%	5,900	0.1%	1,800	4,533	0.3%	2,733	151.8%
Postage	0.4%	21,780	0.4%	7,260	6,510	0.4%	(750)	(10.3%)
Janitorial/Landscape Maint	0.3%	16,800	0.3%	5,600	5,633	0.3%	33	0.6%
Other	1.5%	86,500	1.2%	21,298	44,801	2.7%	23,503	110.4%
Subtotal General / Admin	20.5%	1,148,300	20.3%	368,268	372,961	22.4%	4,693	1.3%
Total Operating Expenses	100.0%	5,596,600	100.0%	1,813,455	1,665,684	100.0%	(147,771)	(8.1%)
Operating Income (Loss)	100.0%	(128)	100.0%	226,999	388,136	100.0%	161,137	71.0%
Non-Operating Expenses								
Drainage Reserve Expenditure	0.0%		0.0%		18,922	100.0%	18,922	0.0%
Total Non-Operating Expenses	0.0%		0.0%		18,922	100.0%	18,922	0.0%
Net Income (Loss)	100.0%	(128)	100.0%	226,999	369,214	100.0%	142,215	62.7%

Rancho Murieta Community Services District
Budget Performance Report by FUND
YTD THROUGH OCTOBER 2013

	% of Total	Annual Budget	% of Total	YTD Budget	YTD Actuals	% of Total	YTD VARIANCE Amount %	
WATER								
REVENUES								
Water Charges	98.7%	\$1,775,230	99.0%	\$767,503	\$768,867	98.7%	\$1,364	0.2%
Interest Earnings	0.0%	80	0.0%	25	60	0.0%	35	140.0%
Other Income	1.3%	23,830	1.0%	7,944	9,959	1.3%	2,015	25.4%
Total Water Revenues	100.0%	1,799,140	100.0%	775,472	778,886	100.0%	3,414	0.4%
EXPENSES (excluding depreciation)								
Wages	28.2%	437,250	26.2%	133,434	130,904	28.3%	(2,530)	(1.9%)
Employer Costs	13.4%	208,130	12.8%	65,233	64,057	13.8%	(1,176)	(1.8%)
Power	10.7%	166,050	9.7%	49,240	48,451	10.5%	(789)	(1.6%)
Chemicals	8.0%	124,500	9.8%	50,035	44,321	9.6%	(5,714)	(11.4%)
T&O - Chemicals/Treatment	3.3%	51,000	6.3%	31,900	11,686	2.5%	(20,214)	(63.4%)
Maint & Repair	10.4%	161,070	10.8%	55,030	55,250	11.9%	220	0.4%
Meters/Boxes	3.5%	54,000	3.2%	16,500	9,906	2.1%	(6,594)	(40.0%)
Lab Tests	2.3%	36,000	2.0%	10,000	8,706	1.9%	(1,294)	(12.9%)
Permits	2.1%	32,000	2.0%	10,000	7,395	1.6%	(2,605)	(26.1%)
Training/Safety	0.5%	7,500	0.5%	2,550	2,702	0.6%	152	6.0%
Equipment Rental	1.5%	23,000	2.0%	10,000	8,173	1.8%	(1,827)	(18.3%)
Other Direct Costs	16.2%	251,070	14.8%	75,398	71,202	15.4%	(4,196)	(5.6%)
Operational Expenses	100.0%	1,551,570	100.0%	509,320	462,753	100.0%	(46,567)	(9.1%)
Water Income (Loss)	16.0%	247,570	52.3%	266,152	316,133	68.3%	49,981	18.8%
38.9% Net Admin Alloc	16.0%	247,570	15.1%	77,123	77,773	16.8%	650	0.8%
Total Net Income (Loss)	0.0%		37.1%	189,029	238,360	51.5%	49,331	26.1%
SEWER								
REVENUES								
Sewer Charges	98.7%	1,237,740	98.7%	412,444	412,272	98.3%	(172)	0.0%
Interest Earnings	0.0%	140	0.0%	42	70	0.0%	28	66.7%
Other Income	1.3%	15,990	1.3%	5,328	7,105	1.7%	1,777	33.4%
Total Sewer Revenues	100.0%	1,253,870	100.0%	417,814	419,447	100.0%	1,633	0.4%
EXPENSES (excluding depreciation)								
Wages	29.7%	315,800	27.6%	96,369	85,582	28.8%	(10,787)	(11.2%)
Employer Costs	14.1%	150,330	13.5%	47,112	42,377	14.3%	(4,735)	(10.1%)
Power	13.5%	143,960	16.6%	58,010	48,350	16.3%	(9,660)	(16.7%)
Chemicals	6.6%	70,300	8.2%	28,660	35,680	12.0%	7,020	24.5%
Maint & Repair	16.2%	172,500	14.0%	49,000	44,158	14.9%	(4,842)	(9.9%)
Lab Tests	3.6%	38,250	3.5%	12,100	15,634	5.3%	3,534	29.2%
Permits	2.6%	27,300	6.0%	21,100	8,445	2.8%	(12,655)	(60.0%)
Training/Safety	1.3%	14,200	1.8%	6,200	1,780	0.6%	(4,420)	(71.3%)
Equipment Rental	1.5%	16,000	1.8%	6,350	706	0.2%	(5,644)	(88.9%)
Other Direct Costs	10.9%	116,240	7.0%	24,319	13,956	4.7%	(10,363)	(42.6%)
Operational Expenses	100.0%	1,064,880	100.0%	349,220	296,668	100.0%	(52,552)	(15.0%)
Sewer Income (Loss)	17.7%	188,990	19.6%	68,594	122,779	41.4%	54,185	79.0%
29.7% Net Admin Alloc	17.8%	189,020	16.9%	58,879	59,379	20.0%	500	0.8%
Total Net Income (Loss)	0.0%	(30)	2.8%	9,715	63,400	21.4%	53,685	552.6%
DRAINAGE								
REVENUES								
Drainage Charges	100.0%	180,430	100.0%	60,140	59,968	99.9%	(172)	(0.3%)
Interest Earnings	0.0%	30	0.0%	8	30	0.1%	22	275.0%
Total Drainage Revenues	100.0%	180,460	100.0%	60,148	59,998	100.0%	(150)	(0.2%)
EXPENSES (excluding depreciation)								
Wages	40.0%	56,680	38.9%	17,297	20,291	49.0%	2,994	17.3%
Employer Costs	19.1%	26,990	19.0%	8,456	9,373	22.6%	917	10.8%
Power	10.9%	15,500	12.0%	5,350	3,698	8.9%	(1,652)	(30.9%)
Chemicals	3.8%	5,400	4.0%	1,800	1,418	3.4%	(382)	(21.2%)
Maint & Repair	8.4%	11,900	9.0%	4,000		0.0%	(4,000)	(100.0%)
Permits	3.5%	5,000	0.0%		4,864	11.7%	4,864	0.0%
Equipment Rental	3.2%	4,500	4.5%	2,000	1,411	3.4%	(589)	(29.5%)
Other Direct Costs	11.1%	15,700	12.5%	5,550	341	0.8%	(5,209)	(93.9%)
Operational Expenses	100.0%	141,670	100.0%	44,453	41,396	100.0%	(3,057)	(6.9%)
Drainage Income (Loss)	27.4%	38,790	35.3%	15,695	18,602	44.9%	2,907	18.5%
6.1% Net Admin Alloc	27.4%	38,820	27.2%	12,089	12,196	29.5%	107	0.9%
Reserve Expenditures	0.0%		0.0%		18,922	45.7%	18,922	0.0%
Total Net Income (Loss)	0.0%	(30)	8.1%	3,606	(12,516)	-30.2%	(16,122)	(447.1%)
SECURITY								
REVENUES								
Security Charges	96.4%	1,185,510	96.4%	395,168	395,082	95.1%	(86)	0.0%
Interest Earnings	0.0%	410	0.0%	106	161	0.0%	55	51.9%
Other Income	3.6%	43,730	3.6%	14,594	20,227	4.9%	5,633	38.6%
Total Security Revenues	100.0%	1,229,650	100.0%	409,868	415,470	100.0%	5,602	1.4%

Rancho Murieta Community Services District
Budget Performance Report by FUND
YTD THROUGH OCTOBER 2013

	% of	Annual	% of	YTD	YTD	% of	YTD VARIANCE	
	Total	Budget	Total	Budget	Actuals	Total	Amount	%
EXPENSES (excluding depreciation)								
Wages	56.8%	\$625,100	56.0%	\$189,000	\$167,830	56.2%	(\$21,170)	(11.2%)
Employer Costs	34.0%	374,700	34.4%	116,300	100,776	33.7%	(15,524)	(13.3%)
Equipment Repairs	0.4%	4,400	0.4%	1,468	6,132	2.1%	4,664	317.7%
Vehicle Maintenance	0.6%	6,700	0.7%	2,225	7,051	2.4%	4,826	216.9%
Vehicle Fuel	1.9%	20,560	2.3%	7,820	5,118	1.7%	(2,702)	(34.6%)
Off Duty Sheriff Patrol	0.5%	6,000	0.6%	2,000	2,985	1.0%	985	49.3%
Other	5.7%	63,040	5.6%	18,821	8,919	3.0%	(9,902)	(52.6%)
Operational Expenses	100.0%	1,100,500	100.0%	337,634	298,811	100.0%	(38,823)	(11.5%)
Security Income (Loss)	11.7%	129,150	21.4%	72,234	116,659	39.0%	44,425	61.5%
20.3% Net Admin Alloc	11.7%	129,190	11.9%	40,232	40,586	13.6%	354	0.9%
Total Net Income (Loss)	0.0%	(40)	9.5%	32,002	76,073	25.5%	44,071	137.7%
SOLID WASTE REVENUES								
Solid Waste Charges	99.9%	621,072	100.0%	207,024	206,888	100.0%	(136)	(0.1%)
Interest Earnings	0.1%	400	0.0%	100	99	0.0%	(1)	(1.0%)
Total Solid Waste Revenues	100.0%	621,472	100.0%	207,124	206,987	100.0%	(137)	(0.1%)
EXPENSES (excluding depreciation)								
CWRS Contract	92.1%	543,000	88.5%	181,000	181,560	94.0%	560	0.3%
Sacramento County Admin Fee	5.9%	34,680	5.7%	11,560	11,533	6.0%	(27)	(0.2%)
HHW Event	2.0%	12,000	5.9%	12,000		0.0%	(12,000)	(100.0%)
Operational Expenses	100.0%	589,680	100.0%	204,560	193,093	100.0%	(11,467)	(5.6%)
Solid Waste Income (Loss)	5.4%	31,792	1.3%	2,564	13,894	7.2%	11,330	441.9%
5.0% Net Admin Alloc	5.4%	31,820	4.8%	9,917	9,997	5.2%	80	0.8%
Total Net Income (Loss)	0.0%	(28)	-3.6%	(7,353)	3,897	2.0%	11,250	(153.0%)
OVERALL NET INCOME(LOSS)	100.0%	(128)	100.0%	226,999	369,214	100.0%	142,215	62.7%

RANCHO MURIETA COMMUNITY SERVICES DISTRICT

INVESTMENT REPORT

CASH BALANCE AS OF OCTOBER 31, 2013

INSTITUTION	YIELD	BALANCE
CSD FUNDS		
EL DORADO SAVINGS BANK		
SAVINGS	0.03%	\$ 590,675.84
CHECKING	0.02%	\$ 8,027.90
PAYROLL	0.02%	\$ 4,331.30
AMERICAN WEST BANK		
EFT	N/A	\$ 15,072.26
LOCAL AGENCY INVESTMENT FUND (LAIF)		
UNRESTRICTED		\$ -
RESTRICTED RESERVES	0.26%	\$ 5,686,168.71
CALIFORNIA ASSET MGMT (CAMP)		
OPERATION ACCOUNT	0.08%	\$ 3,595,793.68
UNION BANK		
PARS GASB45 TRUST (balance as of 8/31/13)		\$ 494,960.99
TOTAL		\$ 10,395,030.68

BOND FUNDS

COMMUNITY FACILITIES DISTRICT NO. 1 (CFD)

BANK OF AMERICA		
CHECKING	N/A	\$ 142,299.93
CALIFORNIA ASSET MGMT (CAMP)		
SPECIAL TAX	0.08%	\$ 8,300.39
US BANK		
SPECIAL TAX REFUND	0.00%	\$ -
BOND RESERVE FUND/ SPECIAL TAX FUND	0.00%	\$ -
TOTAL		\$ 150,600.32
TOTAL ALL FUNDS		\$ 10,545,631.00

The investments comply with the CSD adopted investment policy.

PREPARED BY: Darlene Gillum
Assistant General Manager

MEMORANDUM

Date: November 12, 2013
To: Board of Directors
From: Greg Remson, Security Chief
Subject: Security Report for the Month of October 2013

OPERATIONS

Halloween was mostly quiet. A few smashed pumpkins and a report of a speeding vehicle on Celebrar Street. When the complainant tried to wave down the vehicle so it would slow down, he hit the side mirror, breaking off the mirror. He was not injured.

There were multiple thefts from the Mini-Storage on Cantova Way, and attempted thefts across Cantova Way at the Murieta Village Mini-Storage. Security Patrol Officers provided extra patrol in the area, scheduling was adjusted for extended coverage, Sacramento Sheriff's Department (SSD) was requested for assistance, crime prevention suggestions were given to the owners, and possible suspect information was provided to the Sheriff's Department. There was no forced entry through the gates or fence. The Mini-Storage has installed surveillance cameras and changed the gate access system.

INCIDENTS OF NOTE

October 4, Friday, reported at 10:40 a.m. at the Mini-Storage on Cantova Way. Two (2) vehicles, a truck radio, boat motor, tools and other property were taken overnight. Referred manager to notify tenants to contact SSD for reports. No sign of forced entry.

October 6, Sunday, reported at 9:57 a.m. at the Country Club Snack Bar. A window was pried out and an empty cash drawer was taken overnight. SSD responded for a report and processing for fingerprints.

October 6, Sunday, reported at 10:19 a.m. on Guadalupe Drive. A wallet and garage door opener was taken from an unlocked vehicle.

October 6, Sunday, reported at 2:40 p.m. at the Villas. An unoccupied home was entered. Possible juvenile hang out.

October 7, Monday, reported at 10:04 a.m. on Domingo Drive. Report of a damaged landscaping light.

October 7, Monday, reported at 10:35 a.m. on Camino Del Lago. Report that a spa cover was taken from the back porch.

October 11, Friday, reported at 8:35 a.m. at the Murieta Village Mini- Storage. Report that over the past three (3) weeks an attempt was made to pry open locked doors on two (2) different motor homes. No entry was made.

October 14, Monday, reported at 6:33 p.m. at the RMA office. Report that two (2) juveniles entered the building and stole sodas from the kitchen refrigerator. Subjects located and parents notified.

October 16, Wednesday, reported at 8:20 a.m. at the Murieta Village Clubhouse. Report that five (5) rolls of toilet paper were taken from the restrooms.

October 18, Friday, reported at 2:25 p.m. at the Mini-Storage on Cantova Way. Report that an attempt was made to pry open a locked door on a motor home. No entry was made.

October 20, Sunday, reported at 4:00 p.m. at the Mini-Storage on Cantova Way. Report that a golf cart had been vandalized.

October 21, Monday, reported at 2:18 p.m. at the Mini-Storage on Cantova Way. A motor home was stolen over the past two (2) weeks.

October 24, Thursday, reported at 9:01 p.m. at the Mini-Storage on Cantova Way. A lock was cut from a storage locker and property taken.

During the month of October, District Security Patrol Officers also responded to complaints of loud music, parties and disturbances.

RANCHO MURIETA ASSOCIATION COMPLIANCE/GRIEVANCE/SAFETY COMMITTEE MEETING

The meeting was held on October 7, 2013 at the Rancho Murieta Association (RMA) office. There was one (1) appearance by neighbors complaining about chronic barking dogs, and (1) appearance regarding parking.

JOINT SECURITY COMMITTEE MEETING

The next meeting is scheduled for November 1, 2013. Items on the agenda are Security Surveillance Cameras and Golf Cart Safety.

JAMES L. NOLLER SAFETY CENTER

The Safety Center has been open most Mondays and Wednesdays from 10:00 a.m. to 2:00 p.m. VIPS Jacques Villa and Steve Lentz continue patrolling the District as another set of "eyes and ears".

The Safety Center is also available to all law enforcement officers for report writing, meal breaks and any other needs that arise.

Anyone who is interested in joining the VIPS program or would like information on the Neighborhood Watch program can contact the VIPS at the Safety Center office at 354-8509.

NEW NORTH GATE

At the October 31, 2013 meeting John Sullivan and his design team brought drawings with a new theme that they hope to incorporate into the new North Gate, hotel, and new development on the North side. Some of the ideas had already been discussed and modified by the committee, and that information was sent back to John Sullivan's group for incorporation.

BEACH ACCESS/PTF GATES

Patrol Officers continue to open the gate at dawn and close it at dusk. Calls for service continue to be rare. Due to the occasional driver who drives around the Bass Lake PTF gate, RMA has requested that Security lock the gate located on the east end of Bass Lake. Once RMA has installed reflective warning signs on both sides of the gates, Patrol will begin locking and unlocking the gate at the same time the beach access gate is locked and unlocked.

MEMORANDUM

Date: November 14, 2013
To: Board of Directors
From: Paul Siebensohn, Director of Field Operations
Subject: Water/Wastewater/Drainage Report

The following is District Field Operations information and projects staff has worked on since the last Board meeting.

Water

Water production has dropped slightly with decreasing demands due to cooler weather and shorter days. Water Treatment Plant #1 production is set at 0.9 million gallons per day (MGD) and Plant #2 production is at 0.9 MGD for a total of 1.8 MGD, with facility run times currently around 21 hours per day.

Total potable water production for October 2013 was approximately 55.103 million gallons (MG), or 169.1 acre-feet, down from last month's total flow of 63.8 MG. Based on production versus number of connections, the average usage per customer connection was 680 gallons per day during the month of October. A total of 0.00" of rainfall was recorded for the month with evaporation at 5.52" as measured by the U.S. Bureau of Reclamation at Folsom Lake.

Maintenance at the Water Treatment Plant included: repair of Plant #2, sludge valve number 2; jar tested coagulants to be used with a future water treatment plant (WTP) membrane expansion to determine Total Organic Carbon (TOC) removal (see photo on right); replaced Plant #1 PLC power supply due to failure; replaced Plant #2 traveling bridge PLC due to failure; replace failed and plugged surface scour nozzles at Plant #2 traveling bridge for backwash; and replaced failed sedimentation basin chain of flight sections at Plant #2.

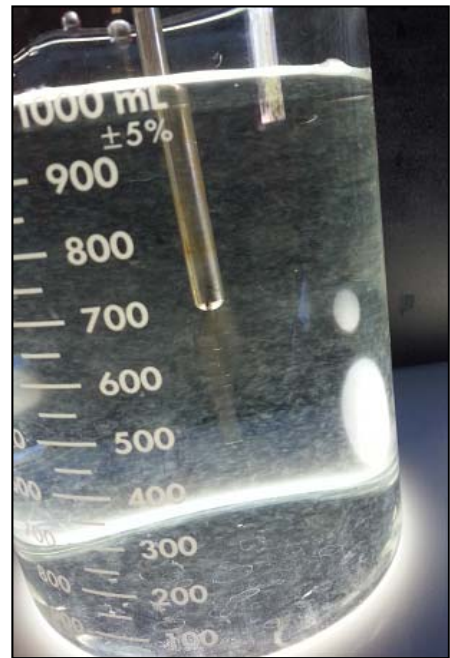

Water Source of Supply

On October 28, 2013, the combined raw water storage for Calero, Chesbro, and Clementia Reservoirs measured approximately 1,041.6 MG (3,196.7 acre-feet). Rancho Murieta Association (RMA) completed their boat ramp project at Chesbro Reservoir and staff began filling it back up with water from Calero Reservoir on October 28. (Photo of boat ramp work on left.)

Wastewater Treatment, Collection & Reclamation

Influent wastewater flow averaged 0.408 million gallons a day, for a total of 12,362,580 gallons, (37.9 acre-feet). Secondary storage measured 18.4 MG (56.4 acre-feet) on October 30, 2013 vs. 10.7 MG (32.8 acre-feet) on October 7. Rancho Murieta Country Club (RMCC) received 141.8 MG (435.3 Ac-ft) of tertiary recycled water during reclamation season.

There were two (2) sewer service calls, both determined to be on the homeowner's property and issues due to root intrusion.

Drainage / CIA Ditch

Staff is focusing on cleaning out culvert pipes and inlets throughout the community prior to the winter season. Our main focus is to ensure the entrances and exits of culvert pipes and the pipes themselves, are clear to accommodate stormwater flows. Staff tested the storm water protection system, including the pumps at Main Lift South and at the FAA field, the flood protection valves at the levee next to Hole #3 on the South, and the sixty inch (60") valve on Murieta Drive near the airport (as shown in photo on the right).



Water metering & Utility Staff work

Staff completed all of the necessary water meter maintenance which included replacement of seventeen (17) water meters, no MXUs or registers. Utility staff repaired three (3) District service line water leaks, eighteen (18) underground service alert (USA) requests, and sixteen (16) Utility Star service orders.



Utility Worker Jeff Hatfield, James Colas, and Jeff Nowell make a water line repair near Rio Blanco Drive

Other Projects

Well Project

Staff is continuing to review the draft well report and well construction design. Staff is also working with Atkins on CEQA documentation.

Water Plant Phase 3

Staff continues to work with HDR and Roebbelen on vendor prequalifications, specifications, and design review.

Main Lift North Rehabilitation Project

The sewer bypass is in place and the lift station rehab has begun. So far, the I-beams have been installed for the hoist and the wet wells demo work has been completed. Currently, Hansen Painting is grit blasting the wetwells in preparation for applying a calcium aluminate cementitious product (Raven 705 CA) for building up the corroded concrete. However, the project is being delayed at this point as groundwater infiltration has been discovered in the bottom of all three (3) wet wells. The delay is due to working to remediate the water infiltration issue. The coating contractor has stated that the coating warranty would be void if we cannot stop the water infiltration, as the coating applied would then be applied outside of the product's required specifications. In the meantime, Hansen has worked to build up the areas of failed concrete with the Raven 705 CA not affected by the groundwater issue. This additional work will likely result in a Change Order, which will be presented at the next Improvements Committee meeting. Once the groundwater issue has been addressed, a specially formulated epoxy coating will be applied. Also left to do is to prepare and paint the I-beams, install the trolley/hoist, move the sewer bypass near the Country Store and trench it across the roadway, and for rehabilitation of the two (2) manholes leading up to the lift station.

Recycled Water for Future Use

Now that the recycled water standards and specifications have been adopted by the Board, we continue to work with AECOM on developing the Title 22 Engineering Report in preparation for the Report of Waste Discharge for the delivery and use of recycled water. To date, there has been no word back from the California Department of Public Health (CDPH) in regard to our confirmation letter for using Bass Lake and Lakes 10/11.

MEMORANDUM

Date: November 13, 2013
To: Board of Directors
From: Improvements Committee Staff
Subject: Adopt the Draft Title 22 Engineering Report

RECOMMENDED ACTION

Adopt the Draft Title 22 Engineering Report prepared by Kevin Kennedy, AECOM.

BACKGROUND

Pursuant to the State of California Water Recycling Criteria (adopted December of 2000) which requires submission of an engineering report to the Regional Water Quality Control Board (Regional Board) and the California Department of Public Health (CDPH) before implementing recycled water projects, the District has prepared a Title 22 Engineering Report.

This document describes the existing recycled water uses for irrigation of two (2) golf courses managed by Rancho Murieta Country Club (RMCC) and irrigation of the Van Vleck Ranch (VVR). Additionally, this document describes the proposed recycled water landscape irrigation uses and the District's ability to continue to comply with the Title 22 requirements with the addition of these proposed uses and expanded service area.

Paul and Kevin met last week with RMCC to continue discussion on joint use of RMCC transmission and lake storage facilities as part of our long term partnering with RMCC.

We will make one last scrubbing effort for the final document.

The Improvements Committee recommends adoption as presented.

Title 22 Engineering Report

Prepared for the
Rancho Murieta Community Services District

November 2013

Prepared by



Contents

Table of Contents

Contents.....	ii
Acronyms and Abbreviations.....	v
1.0 Introduction.....	1
1.1 Purpose.....	1
1.2 Recycled Water Use Areas.....	1
1.2.1 Existing Recycled Water Uses.....	1
1.2.2 Proposed Recycled Water Use Areas.....	3
1.3 Schedule.....	8
2.0 Recycled Water Project.....	9
2.1 General.....	9
2.2 Rules and Regulations.....	9
2.3 Producer – Distributor - User.....	11
2.3.1 Producer Responsibilities.....	11
2.3.2 Distributor Responsibilities.....	11
2.3.3 User Responsibilities.....	13
2.3.4 Other District Responsibilities.....	14
2.4 Raw Wastewater.....	14
2.4.1 Source and Chemical Quality.....	14
2.4.2 Source Control Program.....	15
2.5 Treatment Processes.....	15
2.6 Plant Reliability Features.....	21
2.7 Supplemental Water Supply.....	22
2.8 Monitoring and Reporting.....	23
2.9 Contingency Plan.....	25
3.0 Transmission and Distribution Systems.....	27
3.1 Existing Transmission and Distribution Systems.....	27
3.1.1 North and South Golf Courses.....	27
3.1.2 Van Vleck Ranch.....	29
3.2 Proposed Transmission Improvements.....	29
3.2.1 Phase 1 Improvements.....	31
3.2.2 Phase 2 Improvements.....	32
4.0 Use Areas.....	33
4.1 Irrigation.....	33

4.1.1	Golf Course Irrigation (Existing)	33
4.1.2	Spray Field Irrigation (Existing)	37
4.1.3	Proposed Irrigation	38
4.2	Impoundments	39
4.2.1	Existing Impoundments	39
4.2.2	Proposed Impoundments	40
4.3	Cooling	40
4.4	Groundwater Recharge	41
4.5	Dual Plumbed Use Areas	41
4.5.1	Existing Dual Plumbed Use Areas	41
4.5.2	Proposed Dual Plumbed Use Areas	41
4.6	Other Uses	42
4.6.1	Other Existing Uses	42
4.6.2	Dust Control	42
4.7	Use Area Design	43
4.8	Use Area Inspection and Monitoring	44
4.8.1	Existing Spray Field (Van Vleck Ranch)	44
4.8.2	Existing Golf Courses	44
4.8.3	Proposed Use Areas and Landscape Irrigation Uses	44
4.9	Employee Training	47
4.9.1	District Training	47
4.9.2	RMCC Training	47
4.9.3	Site Supervisor Training	47

List of Figures

Figure 1.	Site Vicinity and Location Map	2
Figure 2.	Existing Recycled Water Use Areas	5
Figure 3.	Proposed Recycled Water Use Areas	6
Figure 4.	WWRP Process Flow Diagram	17
Figure 5.	Recycled Water Flow Diagram	28
Figure 6.	Proposed Recycled Water Transmission and Distribution System Improvements	30
Figure 7.	Signs Used at Golf Course Tees and Road Crossings	35
Figure 8.	Signs Used at Golf Course Lakes	36

List of Tables

Table 1.	Summary of Existing Recycled Water Use Areas	3
Table 2.	Summary of Proposed Recycled Water Use Areas	7
Table 3.	Producer, Distributor, and User Roles and Responsibilities	10
Table 4.	Distributors Associated with Existing Recycled Water Distribution Components	11
Table 5.	Raw Wastewater Quality	15

Table 6. WWRP Design Parameters	18
Table 7. Process Chemicals Used at the WWRP.....	20
Table 8. Summary of Plant Reliability Features	21
Table 9. Summary of Monitoring Requirements.....	23
Table 10. Historic Golf Course Irrigation Demands	33
Table 11. Existing Irrigation Use Area (Van Vleck Ranch).....	37

Appendices

Appendix A - Contact List

Appendix B - Recycled Water Standards

Appendix C - Recycled Water Code

Appendix D - Water Balances

Appendix E - Recycled Water Contingency and Response Plan

Appendix F - Golf Course Irrigation Drawings

Appendix G - Dust Control Guidelines

Acronyms and Abbreviations

ACP	Asbestos Cement Pipe
AF	Acre-feet
AFY	Acre-feet per Year
AWWA	American Water Works Association
CCB	Chlorine Contact Basin
CCP	Chlorine Contact Pipeline
CDO	Cease and Desist Order
CDPH	California Department of Public Health
CEQA	California Environmental Quality Act
cfm	Cubic foot per minute or cubic feet per minute
DAF	Dissolved Air Flotation
District	Rancho Murieta Community Services District
DO	Dissolved Oxygen
ft	Foot or Feet
gpm	Gallons per Minute
lf	Linear Feet
MG	Million Gallons
MGD	Million Gallons per Day
MPN	Most Probable Number
MTI	Murieta Townhomes Inc.
PIP	Plastic Irrigation Pipe
psi	Pounds per square inch
RMA	Rancho Murieta Association
RMCS	Rancho Murieta Community Services District

RMCC	Rancho Murieta Country Club
RP	Reverse Flow Protection Device
RWQCB or Regional Board	Regional Water Quality Control Board
VA	Villas Association
WWRP	Wastewater Reclamation Plant

1.0 Introduction

1.1 Purpose

The State of California Water Recycling Criteria (adopted December 2000) require the submission of an engineering report to the Regional Water Quality Control Board (Regional Board) and the California Department of Public Health (CDPH) before implementing recycled water projects. Pursuant to these requirements, the Rancho Murieta Community Services District (hereafter referred to as “RMCS D” or the “District”) has prepared this Title 22 Engineering Report to establish compliance with the Water Recycling Criteria. The Water Recycling Criteria are contained in Sections 60301 through 60355, inclusive, of the California Code of Regulations, Title 22 and prescribe:

- Recycled water quality and wastewater treatment requirements for the various grades of recycled water and types of allowed uses,
- Reliability features required in the treatment facilities to ensure safe performance, and
- Recycled water Use Area requirements pertaining to the use of the recycled water (including dual plumbed facilities).

This document describes the existing recycled water uses for irrigation of two golf courses managed by the Rancho Murieta Country Club (RMCC) and irrigation of the Van Vleck Ranch. In addition, this document describes the proposed recycled water landscape irrigation and ancillary uses, which will be supported by the District’s ability to continue to comply with Title 22 requirements with the addition of these proposed uses and expanded service area.

1.2 Recycled Water Use Areas

Rancho Murieta is a 3,500-acre residential development located 23 miles east of Sacramento, CA and is bisected by both the Cosumnes River and State Highway 16 as shown in Figure 1. The District owns and operates a wastewater reclamation plant (WWRP) which receives domestic and a relatively small amount of commercial wastewater from the community of Rancho Murieta. The WWRP is capable of producing secondary and tertiary treated wastewater.

1.2.1 Existing Recycled Water Uses

Recycled water has been used successfully to irrigate the two eighteen hole golf courses within Rancho Murieta for approximately 30 years in accordance with Waste Discharge Requirements Order No. 5-01-124. Currently, the total combined irrigation area and demand of the two golf courses is estimated to be 250 acres and 550 AFY, respectively. Currently recycled water deliveries provide, on average about 455 AFY and the remaining 95 AFY is met through raw water diversions from the Cosumnes River.



Sacramento County

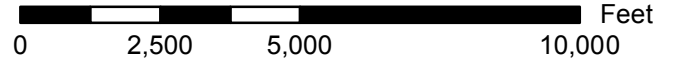

Legend

- District Service Area
- Van Vleck Spray Fields

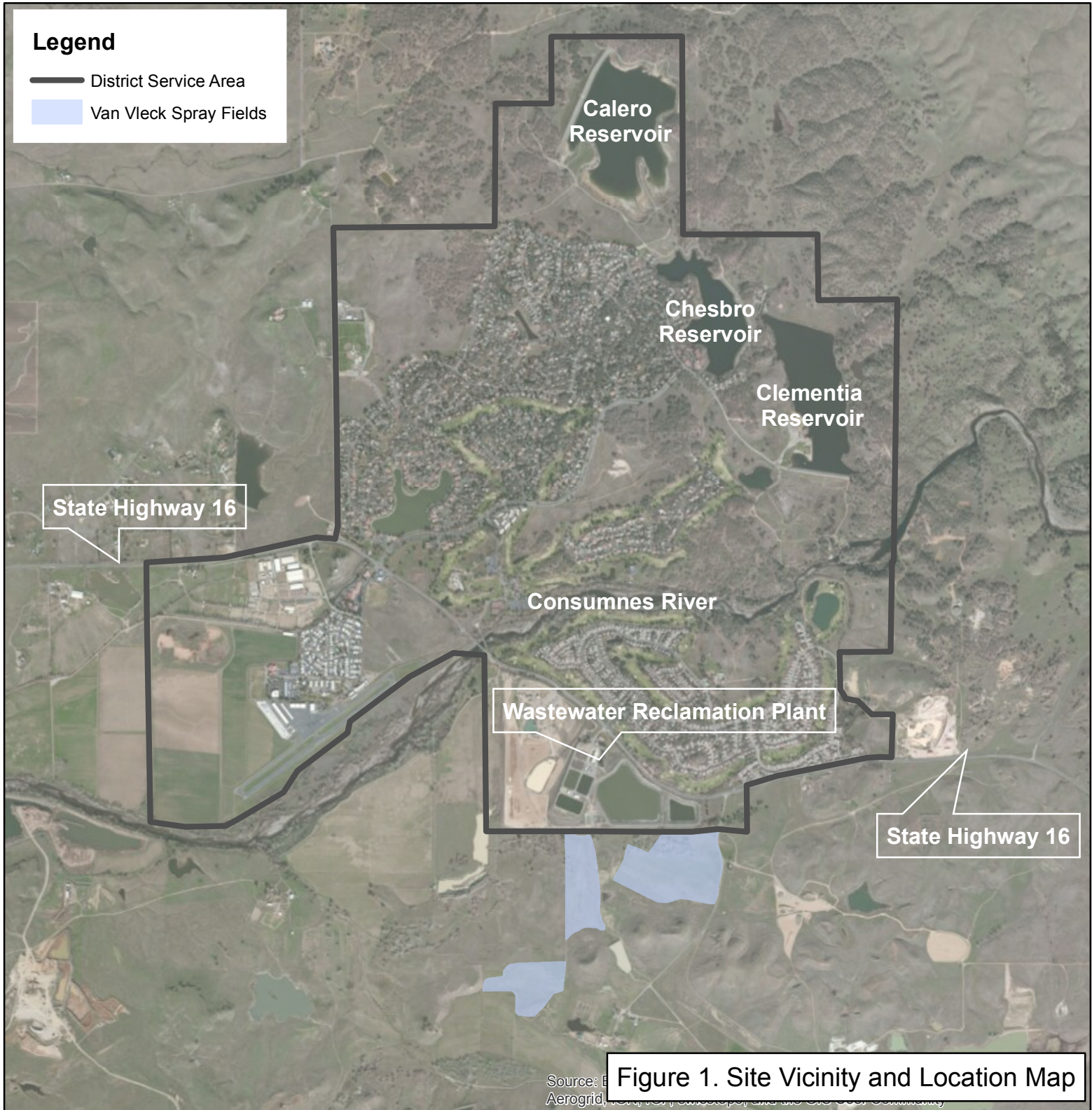

Source: E
Aerogrid

Figure 1. Site Vicinity and Location Map

In 2005, during an abnormally high winter rainfall season, mandatory upgrades to the WWRP’s disinfection process required by the WDR issued in 2001, resulted in a carryover of approximately 300 acre-feet (AF) of stored secondary effluent, which ultimately led to the release of tertiary treated effluent from one of the golf course storage lakes. To address this issue and ensuing Cease and Desist Order (CDO), RMCS D obtained Waste Discharge Requirements Order No. R5-2007-0109 adopted in August 2007 and amended in December 2009, which allows for the irrigation of certain spray fields within the Van Vleck Ranch. The location of the spray fields are immediately south of the WWRP as shown in *Figure 2*. This WDR is set to expire on December 31, 2014. Currently, the total combined spray field area and disposal capacity is 97 acres and 215 AFY, respectively. Table 1 summarizes the existing recycled water uses and disposal capacities. As shown, RMCS D has the ability to dispose of 765 AFY. Currently only 450 AFY is produced by the WWRP.

Table 1. Summary of Existing Recycled Water Use Areas

Area	Description	Assessor’s Parcel Nos.	Approximate Disposal Capacity (AFY)*
North Golf Course	One 18-hole golf courses. Total estimated area of North and South Golf Courses is 250 acres.	07301900060000, 07301900070000, 07301900080000, 07301900090000, 07301900100000, and 07301901080000	550
South Golf Course	One 18-hole golf courses. Total estimated area of North and South Golf Courses is 250 acres.	07307900090000, 07307900100000, 07307900210000, and 07307900350000	
Van Vleck Ranch	Approximately 97 acres of undeveloped pastureland	12800800670000 and 12800800680000	215
Total			765

*Capacities are based on average agronomic rates of 3.3 acre-ft per acre.

1.2.2 Proposed Recycled Water Use Areas

Recycled water has been approved by the California Department of Public Health (CDPH) for a variety of uses. In Rancho Murieta, proposed landscape irrigation and ancillary recycled water uses include the irrigation of parks; greenbelts; playgrounds; athletic fields; residential front and backyard landscaping; common areas; commercial, freeway, highway, and street landscaping; and dust control.

The District is requesting that all of these uses, except for residential front and backyard irrigation, be approved by the CDPH and the RWQCB throughout the District’s service area. Residential front and backyard irrigation use areas would most likely be limited to the developments shown in Figure 3. Table 2 summarizes the estimated number of residential, commercial, and park users associated with each development shown in Figure 3. Altogether,

the projected recycled water demands associated with the developments described in this table and figure equal approximately 415 AFY.

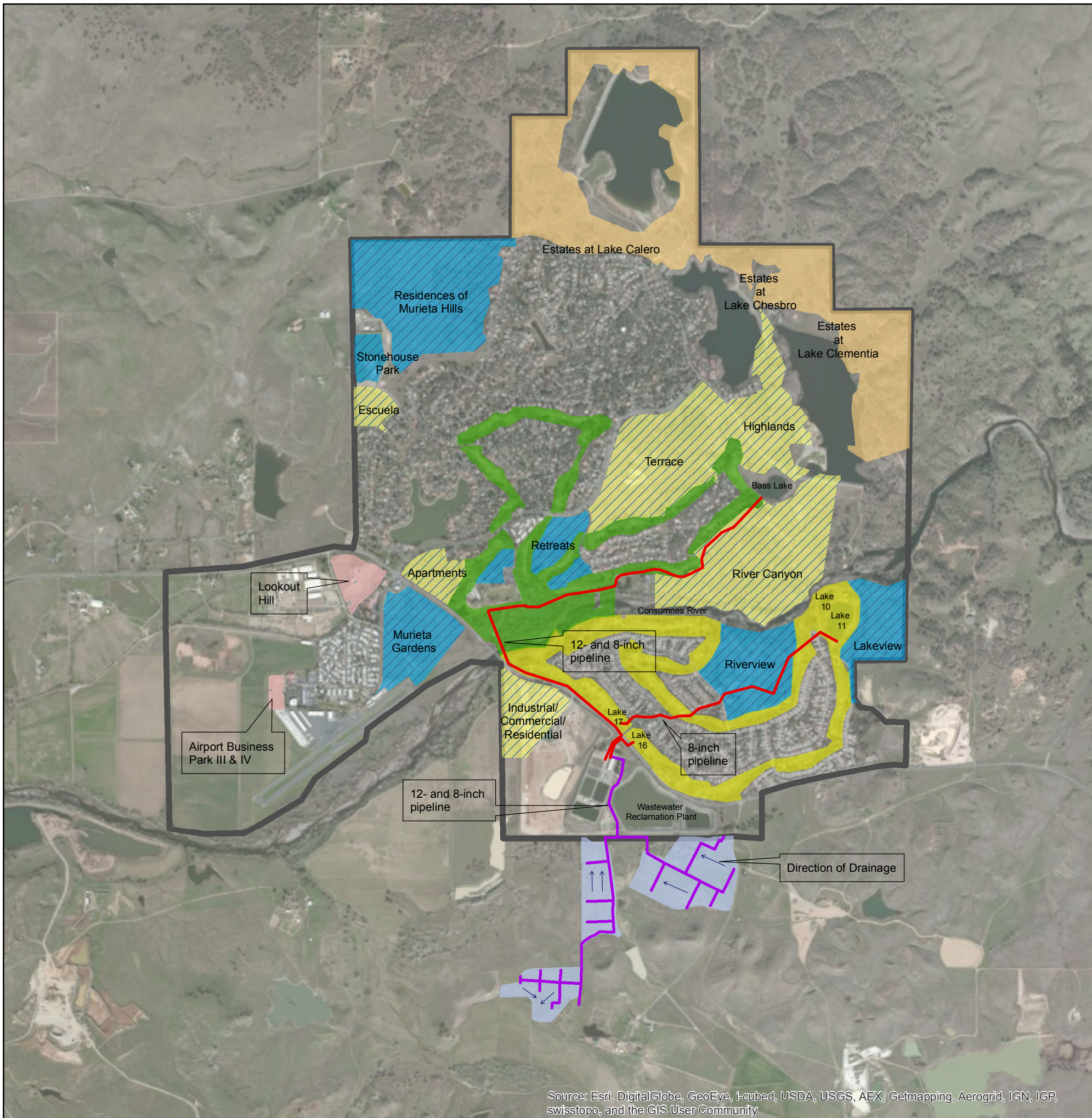

Source: Esri, DigitalGlobe, GeoEye, i-cubed, USDA, USGS, AEX, Getmapping, Aerogrid, IGN, IGP, swisstopo, and the GIS User Community

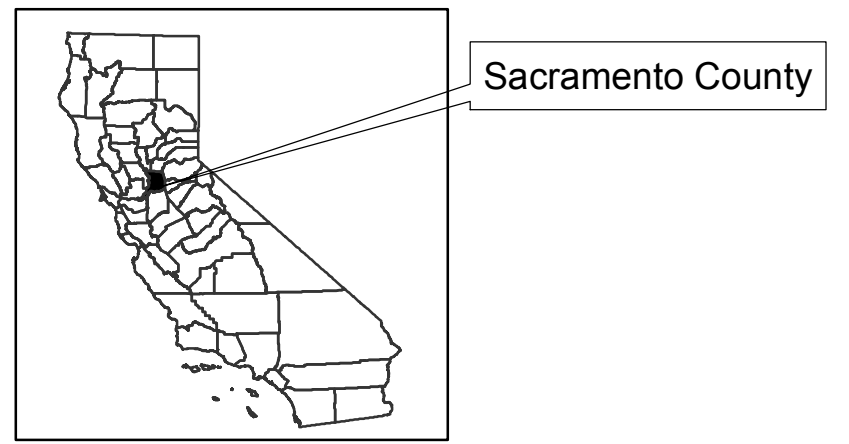
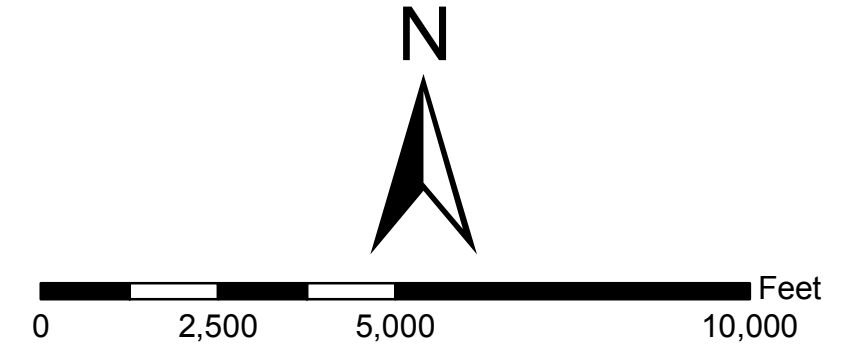
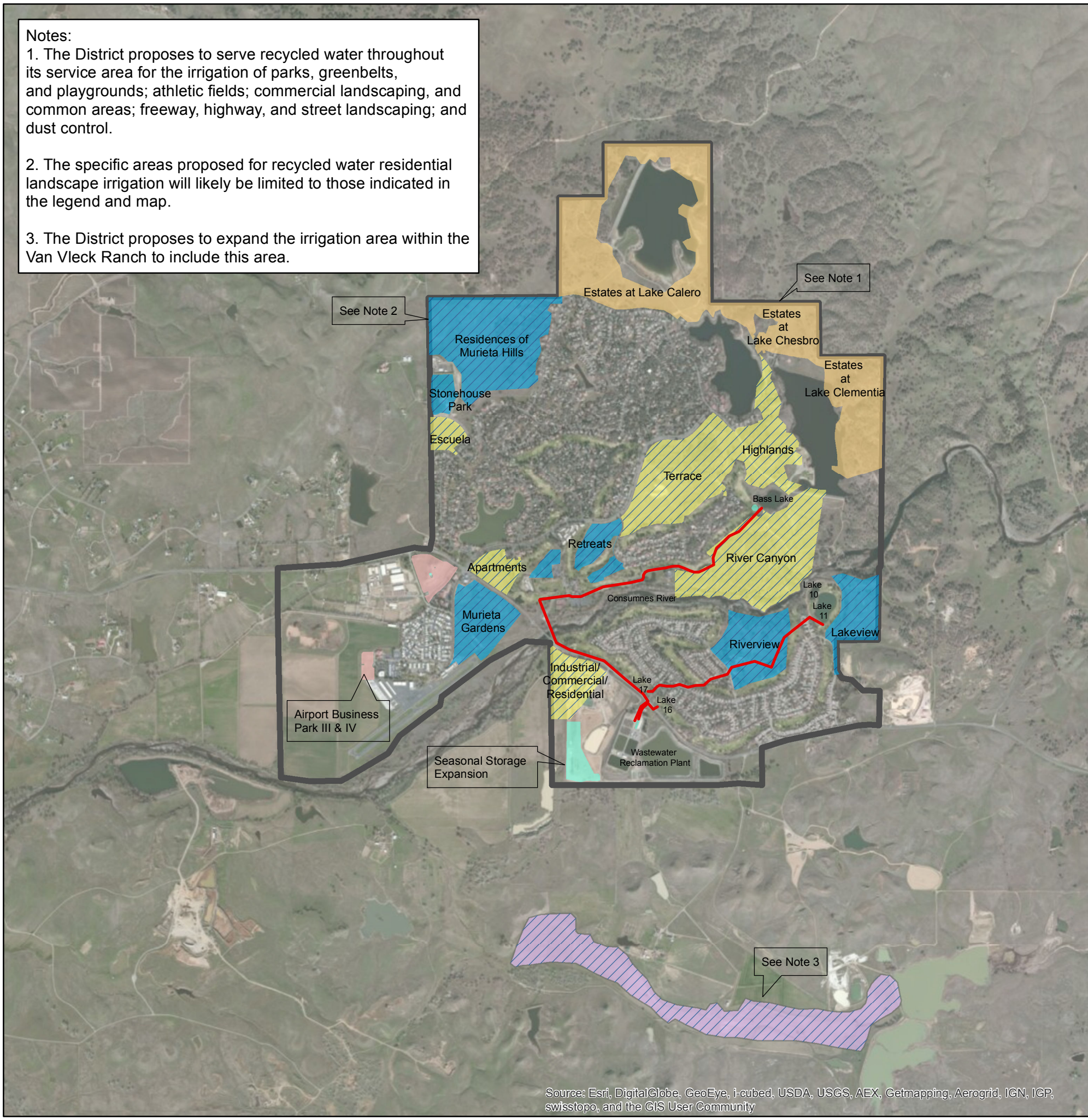

Figure 2. Existing Recycled Water Use Areas

Notes:

1. The District proposes to serve recycled water throughout its service area for the irrigation of parks, greenbelts, and playgrounds; athletic fields; commercial landscaping, and common areas; freeway, highway, and street landscaping; and dust control.
2. The specific areas proposed for recycled water residential landscape irrigation will likely be limited to those indicated in the legend and map.
3. The District proposes to expand the irrigation area within the Van Vleck Ranch to include this area.



Source: Esri, DigitalGlobe, GeoEye, i-cubed, USDA, USGS, AEX, Getmapping, Aerogrid, IGN, IGP, swisstopo, and the GIS User Community

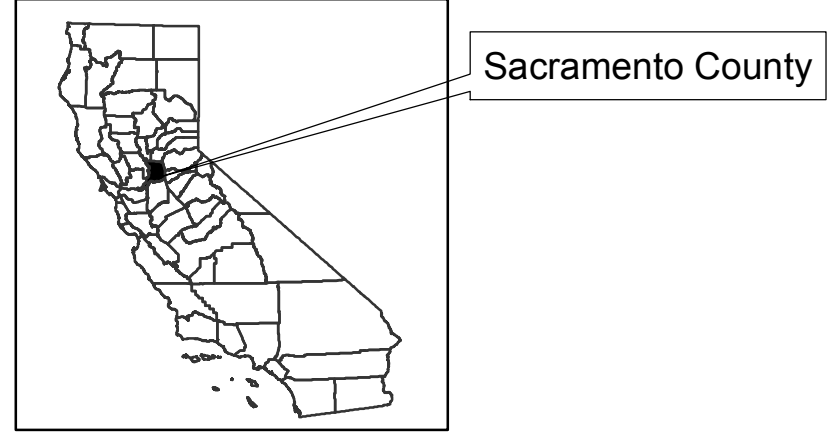
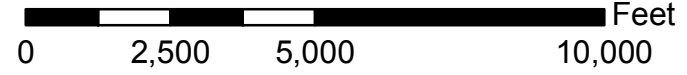

Legend

- Golf Course Conveyance System
- Phase 1 Developments (Proposed Recycled Water Use Area)
- Phase 2 Developments (Proposed Recycled Water Use Area)
- Phase 2 Developments (No Recycled Water Service)
- Van Vleck Ranch (Proposed Spray Field 4)
- District Service Area

Figure 3. Proposed Recycled Water Use Areas

Table 2. Summary of Proposed Recycled Water Use Areas

Development	Description	Parcel Numbers	Disposal Capacity (AFY)
Phase 1 Developments (620 residential units, 50 commercial units, and 2 parks)			
Lakeview	99 residential units	07307900460000	15.8
Murieta Gardens	99 residential and 50 commercial units; 1 acre park	07304700040000, 07304700050000, and 07304700060000	19.6
Residences of Murieta Hills	198 residential units	07301901060000 and 07301901050000	73.8
Retreats	84 residential units	07307900440000 and 07301900990000	18.8
Riverview	140 residential units	07307900070000	22.4
Stonehouse Park	4 acre park (existing)	07301900460000	14.4
		Subtotal	164.8
Phase 2 Developments (717 residential units, 125 commercial units, and 4 acre park)			
Apartments	170 residential units	07301900690000	23.8
Escuela	40 residential units and 4 acre park	07301900250000	25.9
Highlands	110 residential units	07308000090000 and 07308000050000	42.1
Industrial/Commercial/Residential	100 residential and 125 commercial units	07301800290000	50.9
River Canyon	120 residential units	07307900230000	46.4
Terrace	177 residential units	07308000080000, 07308000060000, and 07308000070000	59.9
		Subtotal	249
		Total	413.8

1.3 Schedule

The schedule for the expansion of the recycled water program has been established in two phases based on the following assumed occupancy of the future residential developments:

- Phase 1: 2016 – 2019 (estimated recycled water demand of 165 AFY)
- Phase 2: 2020 – 2026 (estimated recycled water demand of 250 AFY)

The timing of the Phase 1 projects is contiguous with the assumed occupancy schedules for the Lakeview, Murieta Gardens, Retreats, Residences of Murieta Hills, and Riverview developments of 2015 to 2018. For Phase 2, project timing is based on the assumed occupancy schedule for the Escuela, Apartments, Industrial/Commercial/Residential, Terrace, Highlands, and River Canyon developments of 2018 to 2022.

Based on the occupancy schedule described above, and satisfying golf course irrigation demands first, recycled water will not become available for residential landscape irrigation until 2018 when recycled water production is estimated to exceed 500 AFY on average. Comparison of recycled water production and demands estimates indicate there will be about a 100 AFY deficit of recycled water throughout the development period, without the use of the Van Vleck spray fields.

2.0 Recycled Water Project

2.1 General

The RMCSD owns and operates the WWRP which receives domestic wastewater from the community of Rancho Murieta and currently provides secondary- and tertiary-level treatment of recycled water for two specific irrigation activities. The secondary treatment facilities have a rated average annual capacity of 1.55 million gallons per day (MGD) whereas the tertiary treatment facilities have rated filtration and disinfection capacities of 3.0 and 2.3 MGD, respectively. The secondary treatment facilities have sufficient capacity to meet the original service area build-out of 5,200 units. This build-out projection has since been reduced to 4,348 units with a projected average dry weather flow (ADWF) of 0.90 MGD. Currently the estimated ADWF is approximately 0.51 MGD.

The RMCSD and the landowners of the Rancho Murieta Country Club (RMCC) golf courses entered into the *Agreement for the Use of Reclaimed Wastewater* (dated May 17, 1988) and an *Amendment to Agreement for the Use of Reclaimed Wastewater* (dated May 4, 1994). These agreements, as modified by the Waste Discharge Requirements 5-01-124 issued by the Regional Board for the use of recycled water at Rancho Murieta, set forth the operating principles and the respective responsibilities of the RMCSD and RMCC for the use of recycled water on the golf courses. In general, RMCSD is responsible for the operation and maintenance of the collection system, wastewater and tertiary treatment facilities, whereas the RMCC is responsible for the operation and maintenance of the golf course irrigation systems, including transmission pipelines from the WWRP to RMCC facilities, irrigation storage ponds (e.g., Bass Lake and Lakes 10, 11, 16, and 17). In addition and in accordance with their easement agreement and WDR R5-2007-0109, RMCSD manages the treatment, distribution and use of recycled water at the Van Vleck Ranch for pasture irrigation. The use of recycled water at the Van Vleck Ranch is coordinated by the RMCSD with the Van Vleck Ranch manager to allow for movement of the K-line irrigation lines to accommodate periodic grass cutting and cattle rotation.

Table 3 lists the roles associated with the existing and proposed recycled water systems. Specific responsibilities associated with these roles are described in Sections 2.3.1, 2.3.2, and 2.3.3.

2.2 Rules and Regulations

Title 22 of the California Code of Regulations (Water Recycled Criteria) sets the criteria for “disinfected tertiary recycled water”. This designation allows for unrestricted use of recycled water for irrigation, which encompasses the current and proposed uses for recycled water at Rancho Murieta. The criteria are as follows:

- CT (the product of total chlorine residual and modal contact time measured at the same point) must be at least 450 milligram-minutes per liter at all times with a modal contact time of at least 90 minutes.

Table 3. Producer, Distributor, and User Roles and Responsibilities

Use Area	Producer	Distributor	User
Existing			
South Golf Courses	RMCS D	RMCS D	RMCC
North Golf Course	RMCS D	RMCS D	RMCC
Van Vleck Ranch	RMCS D	RMCS D	RMCS D
Proposed Residential Landscape Irrigation			
Murieta Gardens	RMCS D	RMCS D	Property Owners
Residences of Murieta Hills	RMCS D	RMCS D	Property Owners
Retreats	RMCS D	RMCS D	Property Owners
Apartments	RMCS D	RMCS D	Property Owners
Escuela	RMCS D	RMCS D	Property Owners
Highlands	RMCS D	RMCS D	Property Owners
Industrial/Commercial/Residential	RMCS D	RMCS D	Property Owners
River Canyon	RMCS D	RMCS D	Property Owners
Terrace	RMCS D	RMCS D	Property Owners
All Other Proposed Landscape Irrigation Uses			
Service Area	RMCS D	RMCS D	RMA, MTI, VA, and RMCS D
Dust Control			
Service Area	RMCS D	RMCS D	To Be Determined

- Coliform bacteria must not exceed:
 - Most probable number (MPN) of 2.2 per 100 mL (7-day median),
 - MPN of 23 per 100 mL (one sample in 30 days), and
 - Never exceed an MPN of 240 per 100 mL.
- Turbidity of filtered tertiary water must not exceed:
 - 2 NTU (average),
 - 5 NTU (up to 5% of the time), and
 - Never exceed 10 NTU.

The Rancho Murieta WWRP recycled water effluent meets all of these criteria.

RMCS D recently adopted Recycled Water Standards (October 16, 2013) and the Recycled Water Code (January 18, 2012). District Code, Chapter 17 (Recycled Water Code) sets forth rules and regulations regarding the use of recycled water in Rancho Murieta. The Recycled Water Standards define District procedures, design, work, materials, capacities, facilities and other improvements pertaining to recycled water facilities or connections.

Together the Recycled Water Code and Recycled Water Standards establish and provide the means to enforce rules and regulations for recycled water users, design and construction of recycled water facilities, and the use of recycled water in accordance with federal and state reclamation criteria. Copies of the Recycled Water Standards and Recycled Water Code are provided in Appendix B and C.

2.3 Producer – Distributor - User

Table 3 summarizes the producer, distributor, and user roles for the existing and proposed recycled water systems. The following are descriptions associated with these roles.

2.3.1 Producer Responsibilities

Key responsibilities of the Producer (i.e., RMCS D for both the existing and proposed recycled water systems) are to operate the WWRP and produce recycled water which complies with the standards set forth for “disinfected tertiary recycled water” as defined by Section 60301.230 of Title 22. The District is responsible for obtaining and complying with Waste Discharge Requirements, which describe requirements and limitations associated with recycled water production and WWRP operation, maintenance, and monitoring.

2.3.2 Distributor Responsibilities

Key responsibilities of the Distributor (i.e., RMCS D and RMCC for both the existing and proposed recycled water systems) include the conveyance of recycled water from the WWRP to the point of use, establishing design criteria, and the operation and maintenance of the facilities associated with this activity. Table 4 lists the entities that currently own, operate, and/or maintain the facilities associated with existing recycled water uses.

Table 4. Distributors Associated with Existing Recycled Water Distribution Components

Distribution Component	Own	Operate	Maintain
Equalization Basin	RMCS D	RMCS D	RMCS D
South Golf Course ^a			
12-inch Gravity Pipeline	RMCS D	RMCS D/RMCC ^b	RMCS D/RMCC ^b
Lakes 16 and 17 ^c	RMCC	RMCC	RMCC
Lake 17 Pump Station	RMCC	RMCC	RMCC
8-inch Transfer Pipeline	RMCC	RMCC	RMCC
Lakes 10 and 11	RMCC	RMCC	RMCC

Lake 10 and 11 Pump Station	RMCC	RMCC	RMCC
South Course Irrigation System	RMCC	RMCC	RMCC
North Golf Course ^a			
North Course Pump Station	RMCCSD	RMCCSD	RMCCSD
12-inch Pressure Pipeline ^c (WWRP to the Yellow Bridge)	RMCCSD	RMCCSD/RMCC ^b	RMCCSD/RMCC ^b
8-inch Pressure Pipeline (Yellow Bridge to Bass Lake)	RMCC	RMCC	RMCC
Bass Lake	RMCC	RMCC	RMCC
Bass Lake Irrigation Pump Station	RMCC	RMCC	RMCC
North Course Irrigation System	RMCC	RMCC	RMCC
Van Vleck Ranch ^d			
Recycled Water Pump Station	RMCCSD	RMCCSD	RMCCSD
6-inch Transmission Pipeline	RMCCSD	RMCCSD	RMCCSD
Spray Field Irrigation System	RMCCSD	RMCCSD	RMCCSD

^a Agreement for Availability of Use of Reclaimed Water (dated May 17, 1988).

^b According to the Amendment to Agreement for Availability of Use of Reclaimed Water (dated May 4, 1994), RMCCSD and RMCC agreed to share operation and maintenance costs on a 50/50 basis.

^c Equivalent Point of Connection

^d Grant and Agreement Regarding Temporary Irrigation Easement (dated August 13, 2007).

With respect to recycled water irrigation of future residential developments, RMCCSD shall be responsible for establishing the design criteria and review of Recycled Water Plans for offsite and onsite facilities, as well as the operation and maintenance of the distribution of recycled water up to the Point of Connection (i.e., recycled water meter), except for RMCC facilities.

Individual home owners shall be responsible for the onsite design (in compliance with the District's Recycled Water Standard), operation, and maintenance of their recycled water landscape irrigation system downstream of the Point of Connection. Furthermore, as described in Recycled Water Standards, the District reserves the right to control and schedule the use of recycled water to maintain acceptable working conditions within the recycled water systems. These and other recycled water distribution conditions will be administered by the District at its discretion. Where repairs or replacement of a service pipeline upstream of the Point of Connection is required, it shall be the responsibility of the District. Conversely, the cost of repairs or replacement of components downstream of the Point of Connection shall be the responsibility of the property owner and made within the timelines described in the Recycled Water Code.

2.3.3 User Responsibilities

The RMCC is responsible for the use of recycled water for golf course irrigation as well as the operation and maintenance of the golf course irrigation systems and irrigation storage ponds. As previously described, RMCCSD manages the use of recycled water at the Van Vleck Ranch. The use of recycled water at the Van Vleck Ranch is coordinated by the RMCCSD with the Van Vleck Ranch manager to allow for movement of the K-line irrigation lines to accommodate periodic grass cutting and cattle rotation.

In the future, it is envisioned that the Rancho Murieta Association (RMA), Murieta Townhomes Inc. (MTI), Villas Association (VA), and RMCCSD will be responsible for the use of recycled water for landscape irrigation. As described in the Recycled Water Standards, individual owners of homes using recycled water for front and backyard landscape irrigation shall be responsible for maintaining and operating the recycled water system downstream of the Point of Connection and ensuring that recycled water use is in accordance with all applicable rules and regulations. More specifically, all irrigation users must:

- Designate a site supervisor that receives training by attending a District-sponsored Recycled Water Orientation or be able to demonstrate knowledge of the application and maintenance of their recycled water system.
- Be aware of, and familiar with the District's Recycled Water Standards and Recycled Water Code and knowledgeable about the practices and procedures of using recycled water.
- Obtain all permits and pay all fees required to establish, operate, and maintain their recycled water system.
- Ensure that all materials used during the design, construction, and maintenance of the system are approved or recommended for recycled water use.
- Routinely monitor and inspect the recycled water system for any situation that may not be in conformance with the regulatory requirements. Problems such as irrigation controller malfunctions, irrigation schedule adjustments, excessive ponding or runoff of recycled water, broken or out-of-adjustment sprinkler heads, etc. must be corrected as soon as they become apparent.
- Maintain the use area's recycled water system downstream of the Point of Compliance.
- Report all violations and emergencies to the required local governing agencies.
- Obtain prior written authorization from the District and any required regulatory agency before making any modifications to an approved recycled water system, or to the potable water system if it is in close proximity to the recycled water system.

2.3.4 Other District Responsibilities

As described in Section 2.2.9 of the Recycled Water Standards, the District shall be responsible for eliminating or controlling conditions that directly or indirectly cause runoff or windblown spray to pass outside of approved recycled water Use Areas or cause ponding or overspray of recycled water whether by design, construction practice, or system operation to the greatest extent possible through the use of the following Best Management Practices (BMPs):

- Proper design, selection, operation, and maintenance of sprinkler heads.¹
- Implementation of operations and management plans that provide for detection of leaks, and correction within 72 hours of learning of a leak or prior to the release of 1,000 gallons.¹
- Refraining from application during precipitation events.¹
- Management of any impoundment such that no discharge occurs unless the discharge is a result of a 25-year, 24-hour storm event or greater. In the event of an unauthorized discharge, the Executive Officer of the RWQCB shall be notified in writing within thirty (30) days.¹

Areas irrigated with recycled water shall be managed to prevent ponding and conditions conducive to the proliferation of mosquitoes and other disease vectors, and to avoid creation of a public nuisance or health hazard. The following practices shall be implemented, at a minimum:

1. Irrigation water must infiltrate completely within a 48-hour period.
2. Ditches receiving irrigation runoff, not serving as wildlife habitat, shall be maintained free of emergent, marginal and floating vegetation.
3. Low-pressure and unpressurized pipelines and ditches that may be accessible to mosquitoes shall not be used to store recycled water.

2.4 Raw Wastewater

2.4.1 Source and Chemical Quality

The source of raw wastewater for the WWRP is residential homes in the Rancho Murieta community and a few commercial facilities (e.g., stores, restaurants, bank, etc.) within the community. There are no industrial activities that discharge wastewater to the WWRP. Current

¹ One of the four required Administrator BMPs as required by Recycled Water Specification B. 15 of WQO No. 2009-0006-DWQ

influent flows are approximately 0.5 MGD, and projected future flows are expected to be approximately 0.9 MGD based on the anticipated level of development. As described later in this report, raw wastewater monitoring is limited to flow, five-day biochemical oxygen demand (BOD₅), and total suspended solids (TSS).

The raw wastewater quality data for 2010 and 2011 are summarized below in Table 5.

Table 5. Raw Wastewater Quality

Parameter	Range (mg/L)	Median (mg/L)	95 th Percentile (mg/L)
Flow	0.28-1.20	0.50	0.69
BOD	104 - 266	175	260
Total Suspended Solids	113 - 410	205	318

2.4.2 Source Control Program

The wastewater generated at Rancho Murieta is domestic with minimal commercial contributions; therefore, a pretreatment program is not required. It is expected that future developments will continue to discharge domestic wastewater. RMCS D Sewer Code prohibits the discharge of toxic chemicals and other harmful compounds to the sewer. Residents and businesses routinely receive written materials describing substances that are prohibited from discharge into sewers for the protection of the wastewater treatment processes or cause the recycled water to be unsuitable for irrigation.

2.5 Treatment Processes

The WWRP consists of both a secondary wastewater facility and a tertiary treatment plant. It is designed to treat an average annual flow of 1.55 MGD and a peak flow of 3.00 MGD in the secondary treatment ponds (a series of five aerated facultative ponds). Seasonal storage (October to March) of the secondary treated wastewater is provided in two storage reservoirs, which have a combined storage capacity of approximately 238 million gallons (MG) or 728 AF. Approximately 170 AF of additional seasonal storage capacity may be installed to accommodate anticipated projected growth within the community. The assumed timing for Phase 1 and 2 developments requires this project to be initiated in mid- to late-2018 and completed by the end of 2019 when average dry weather flows to the WWRP approach 0.67 MGD. The process flow diagram for the WWRP is shown in

Figure 4. The major components of the WWRP are as follows:

- Five aerated facultative ponds and two secondary storage reservoirs,
- Two dissolved air flotation (DAF) units
- Two sand filtration units
- Chlorine contact detention facilities
- Equalization basin
- Recycled water pump station

Raw wastewater is pumped to the WWRP through three pumping stations located throughout Rancho Murieta. Raw wastewater enters the WWRP at Pond #1. The WWRP is equipped with a system to add chlorine to the raw wastewater before entering Pond #1 if needed. Pond #1 contains five rotating brush and floating aerators all of which run continuously, to provide dissolved oxygen (DO) and maintain DO levels in the pond above a concentration of 1 mg/L. The aerators in the other ponds are managed by District operations staff that set the timers to maintain proper DO levels. The effluent from Pond #1 flows by gravity through the remaining ponds in sequential order. Ponds #2 and #3 each contain three aerators; Pond #4 has two, and Pond #5 has one aerator. There is one solar powered mixer in each of the five treatment ponds, and the ponds are equipped with piping such that any pond can be bypassed while keeping the plant in operation. In addition, all ponds except Pond 1 can be drained completely for sludge removal and/or repairs.

The capacity of the tertiary filtration facilities is 3.0 MGD. However, the limiting capacity of the overall tertiary treatment process is 2.3 MGD due to the existing chlorine contact basin. The District will be initiating an upgrade to this facility by adding chlorine contact capacity through the addition of concrete walls within the existing equalization basin to increase the rated disinfection capacity to 3.0 MGD. The District estimates that this project should be completed prior to serving recycled water to additional landscape irrigation customers (e.g., 2018 or thereabouts depending on development and funding capabilities). After tertiary treatment, the recycled water is stored in an equalization basin located at the WWRP prior to conveyance to the Use Areas. This basin has a capacity of 1.8 MG.

The design parameters for the WWRP are summarized in Table 6.

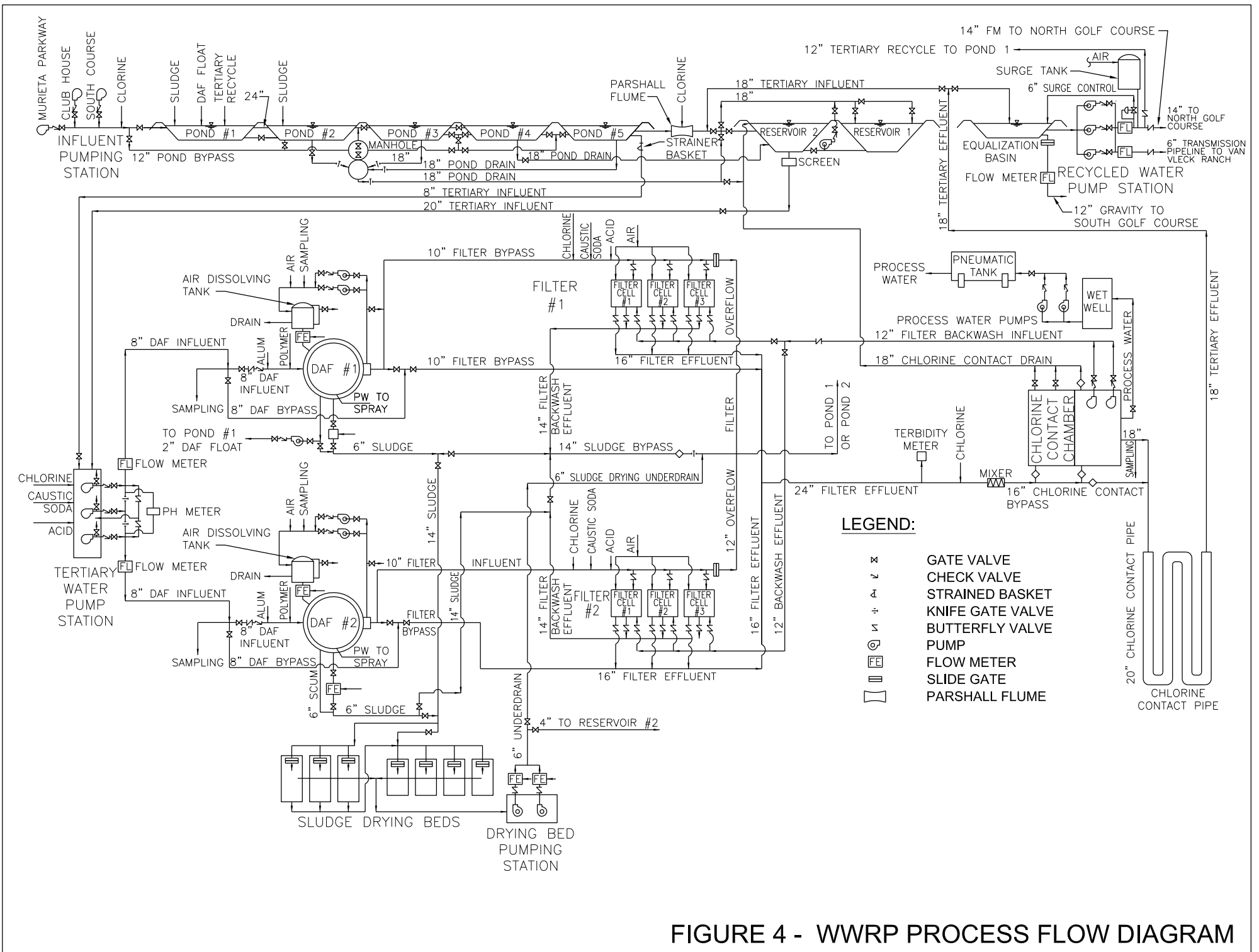

FIGURE 4 - WWRP PROCESS FLOW DIAGRAM

Table 6. WWRP Design Parameters

Parameter	Value				
Design Flows					
Average daily flow:	1.55 MGD (secondary) 3.0 MGD (tertiary) 2.3 MGD (disinfection)				
Control:	Continuous operation				
Secondary Treatment					
Number of basins:	5				
Volume: (each basin – ft ³)	345,870	349,350	787,560	1,157,390	737,040
Hydraulic Detention Time (days) at 1.55 MGD	1.7	1.7	3.8	5.6	3.6
Number of Surface Aerators (each basin)	5	3	3	2	1
Tertiary Treatment					
Tertiary Water Pump Station					
Number of Units (Pumps)	3				
Type of Pumps	Vertical Turbine				
Horsepower	25 (each pump)				
Number of Stages	3				
Column Length	49 feet, 7 inches (per specifications)				
Capacity (unthrottled)	1,150 gpm @ 43 feet TDH				
Capacity (throttled)	950 gpm @ 75 feet TDH				
Dissolved Air Flotation (DAF)					
Number of Units	2				
Capacity (each unit)	1.5 MGD				
Diameter (ft.)	27				
Side Water Depth (ft.)	11.75				
Number and Type of Pumps @DAF Pump Station	3 – (2 duty, 1 standby) Vertical turbine				
Flow Rate (gpm)	1,150 gpm @ 43 ft. TDH 950 gpm @ 75 ft. TDH				
Air Flow Rate (cfm)	1.0				
Recirculation Pumps	2 each 320 gpm @ 87 psig				
Gravity Sand Filters					
Number of Filters	2				
Approx. Overall Dimensions (ft.)	11 (W) x 30 (L) x 9 (D)				

Media Depth (inches)	10
Number of Filter Cells (per filter)	3
Hydraulic Loading	3.16 – 4.74 with one cell out of service
Surface Area per Cell	100 ft ²
Backwash Flow Rate (gpm)	1,320 @ 25 ft. TDH (2 pumps – 1 duty, 1 standby)
Chlorination	
Chemical Feed Pump Type:	Chlorinators
Quantity:	2, 1 each for Pre-Chlorination and Post-Chlorination
Post Chlorine Dosage:	8 mg/L
Control Strategy	Manually flow paced
Chlorine Gas Storage	
Storage Tank Type:	Ton Canister Storage
Quantity Tanks:	4 (minimum)
Operation:	2 Canisters on-line, 2 stand-by Automatic switch-over as needed
Chlorine Contact & Detention Facilities	
Length to Width Ratio	66:1
Length to Depth Ratio	33:1
Chlorine Contact Pipeline	2 – parallel 20-inch diameter PIP at 3,300 linear feet each
Total Contact Time	100 minutes at 2.3 MGD

The secondary effluent flows into two storage reservoirs, which store the secondary treated wastewater over the winter months when recycled water is not being produced and the tertiary treatment facility is not in operation.

The storage reservoirs have a combined capacity of 728 AF, with two feet of freeboard. The current capacity is sufficient to contain approximately 238 million gallons of secondary treated wastewater annually. The water balances developed for 100-yr levels of annual precipitation (see Appendix D) demonstrate that there is sufficient capacity to contain the secondary treated wastewater over the winter months when recycled water is not in production until average dry weather flows are equal to 0.65 MGD. After that, an additional 220 AF of secondary effluent storage is required for the projected average dry weather flow of 0.91 MGD.

The tertiary treatment system consists of a tertiary water pump station, coagulation, DAF units, gravity sand filters, chlorine contact tank, chlorine contact pipe, equalization basin, the Recycled Water Pump Station, and the 12-inch South Course gravity pipeline. The Tertiary Water Pump Station, which has a capacity of over 3.0 MGD, pumps secondary treated wastewater from Secondary Storage Reservoir #1 to the DAF units. Alum and chlorine are added, with polymer

being an option, to the stream prior to the DAF units to promote solids coagulation (mostly algae). Typical turbidity entering the DAF units is approximately 2 NTU. Following DAF treatment, water flows into two sets of sand filtration units. The typical influent and effluent turbidities for the sand filters are 1 NTU and 0.25 NTU, respectively. The sand filters are backwashed based on the headloss measured through the filters. A water level float switch is located in each filter, and when the water level increases to a specific set point, the filter is automatically backwashed. The average number of backwash cycles per day during normal operation is two to four. The backwash water source is recycled water obtained from the chlorine contact basin. The backwash flow rate and duration are approximately 1,300 gpm or 12 gpm/ft² per cell and approximately 3.5 minutes.

Chlorine is then added to the filtered effluent as it flows into the chlorine contact tank. A chlorine contact time of 100 minutes, at a maximum flow rate of 2.3 MGD, is provided by the concrete chlorine contact basin (CCB) followed by a chlorine contact pipeline (CCP). A dye tracer test was conducted on the disinfection system to verify the modal contact time, as reported in WWRP Modified Chlorine Contact Disinfection System Compliance Report (HSe, 2006). Approximately 6,600 linear feet of 20-inch plastic irrigation pipe (PIP) was installed in the equalization basin to provide additional contact time. Water leaving the CCP is stored in the equalization basin before used for recycled water irrigation.

Sludge from the DAF units and the sand filter backwash is pumped to the sludge drying beds where, after drying, the sludge is stored and disposed at a landfill. The sludge drying bed under-drain system collects filtrate from the drying beds. The filtrate is then pumped by the drying beds pumps to treatment Ponds #1 or #2. Alternatively, sludge may be diverted from the DAFs directly to Ponds #1 or #2.

Chemicals used and their purpose, delivery method, application point, and approximate dosage are summarized in Table 7.

Table 7. Process Chemicals Used at the WWRP

Chemical	Purpose	Delivery Method	Application Point	Dosage ^a (mg/L)
Gas Chlorine	Disinfection	1.) Direct injection 2.) Direct injection; inline mixer	1.) Before DAF 2.) Before Chlorine Contact tank	1.) 8 2.) 8
Aluminum Sulfate (Alum)	Coagulation	Direct injection	Before DAF	100 - 300
Polymer	Coagulation	Direct injection	Before sand filter DAF	As needed
Sodium Hydroxide (Caustic Soda)	pH control	Direct injection	Before chlorine contact tank	As needed

^a Dosages are approximate and vary depending on site conditions.

All Operation and Maintenance Manuals for the equipment used at the WWRP are stored in the Operator Supervisor Office which is located in the WWRP Maintenance Building or in the WWRP Laboratory Building along with the current Sludge Management Plan.

2.6 Plant Reliability Features

Sections 60333 through 60355 (Articles 8 through 10) of the Water Recycling Criteria describe the reliability features for wastewater treatment plants producing recycled water. The features that have been incorporated into the WWRP which comply with the applicable requirements are described in Table 8. The WWRP monitored at all times and is fully staffed between 7:00 am and 4:00 pm, seven days a week, and with a minimum of one operator on-call during all other hours.

Table 8. Summary of Plant Reliability Features

Water Recycling Criteria Section ^a	WWRP Features
60333 – Flexibility of Design	<ul style="list-style-type: none"> • Availability of redundant and standby equipment • Bypass capabilities for all major components of the WWRP to prevent loss of treatment in the event of equipment failure or required maintenance • Substantial recycled water storage provided in the storage reservoirs
60335 – Alarms	<ul style="list-style-type: none"> • WWRP operations on a PLC base control system • Alarm alerts: <ul style="list-style-type: none"> ○ Loss of power from normal supply ○ High (greater than 5 NTU) turbidity after ponds ○ Low chlorine residual (less than 5 mg/L) in tertiary effluent ○ Failure of the coagulation process ○ High (greater than 2 NTU) turbidity after sand filters ○ High water level in equalization basin • Backup power from on-site auxiliary system for alarm systems • Automatic shutdown of tertiary treatment plant when alarm condition occurs. 24-hour security staff is automatically alerted and will contact the operator on call. Recycled water flow can be stopped simply by shutting down the recycled water pump station; no automatic actuation equipment is required.
60337 – Power Supply	<ul style="list-style-type: none"> • Loss of power alarm is triggered when power service is interrupted and the auxiliary power generator is automatically brought on-line • Auxiliary power generator capable of powering the entire WWRP and administrative building
60341 – Emergency Storage	<ul style="list-style-type: none"> • Extensive storage provided in the WWRP. Secondary treatment system designed to store effluent for the duration of the winter months, when irrigation production is zero. Storage reservoirs can contain excess of 20 days of storage without any special diversions or equipment. • Several days of storage at equalization basin for tertiary treated wastewater
60345 – Biological Treatment	<ul style="list-style-type: none"> • Secondary treatment ponds capable of treating wastewater at an average annual flow of 1.55 MGD with one pond out of service • Pond system is equipped with piping and valves to bypass any pond for cleaning, maintenance, or repairs.

60349 – Coagulation	<ul style="list-style-type: none"> • Tertiary treatment uses two DAF and two sand filtration units in series to achieve low turbidity recycled water. Two parallel trains are used, and one train can be taken out of service without interrupting operations. • Alum is added to the secondary effluent stream prior to DAF units to aid in coagulation. The alum feed system has three pumps (one standby), automatic dosage control, and a reserve chemical supply.
60351 – Filtration	<ul style="list-style-type: none"> • Tertiary treatment uses two DAF and two sand filtration units in series to achieve low turbidity recycled water. Two parallel trains are used, and one train can be taken out of service without interrupting operations. • Turbidity is measured continuously before and after the sand filters. If turbidity in the filter effluent exceeds 2 NTU, an alarm is triggered and the recycled water pump station is automatically shut down.
60353 – Disinfection	<ul style="list-style-type: none"> • Disinfection system consists of <ul style="list-style-type: none"> ○ Two chlorinators ○ Chlorine cylinders ○ Scales ○ Manifold system ○ Chlorine contact basin and extended contact pipeline ○ Effluent chlorine residual analyzer / monitor • Chlorine is added before the DAF units and prior to the chlorine contact basin. • When primary chlorine cylinder empties the standby cylinder automatically becomes the primary unit and the operator is alerted. • When the primary chlorine capacity drops below 40%, the operator is alerted. • Spare repair kits are kept on-site for immediate repair of the chlorinators if necessary. • Monitoring: <ul style="list-style-type: none"> ○ Manual monitoring between the CCB and CCP. ○ Automatic monitoring by on-line instrumentation at the termination of the chlorine contact pipeline. • If the chlorine residual drops below 5 mg/L at the termination of the chlorine contact pipeline, the recycled water pump station is automatically shut down. • The recycled water chlorine concentration is kept at 5.5 mg/L or 0.5 mg/L greater than the required minimum residual concentration to allow for slight variations in the recycled water chlorine residual. • Daily grab samples of the effluent are collected and submitted to a certified laboratory for Total Coliform (15 tube count) analysis.

^a Sections 60339, 60343, 60347, and 60355 do not pertain to the WWRP.

2.7 Supplemental Water Supply

Currently, the WWRP does not produce enough recycled water to meet the full irrigation demands of the golf courses, and thus supplemental water must be provided to satisfy golf course irrigation demands. The recycled water system for the golf courses is currently supplemented with river water from the Cosumnes River. RMCC's river pumps divert water

from the Cosumnes River to Bass Lake and Lake 10 where it is stored for future golf course irrigation in the spring. Currently, recycled water production is estimated to be 455 acre-ft per year AFY, whereas golf course demands based on average levels of annual precipitation are 550 AFY. It is estimated that recycled water production will exceed golf course irrigation demands in 2018 based on the development timeline described in Section 1.3. However, at full build-out, all golf course irrigation will be supplied by recycled water, and river water will be used only for emergency purposes.

In the near future, the golf course irrigation system will continue to be supplemented with river water from the Consumes River. However residential, park, and commercial irrigation systems will still be supplemented with water obtained from the District’s potable water system. Most likely, potable water supplementation will occur at recycled water storage tanks or at the equalization basin located at the WWRP. In either case, an approved air gap separation will be provided in accordance with the District’s Recycled Water Standards.

2.8 Monitoring and Reporting

RMCS D currently monitors and reports in accordance with the requirements specified in Monitoring and Reporting Program Nos. 5-01-124 and R5-2007-0109-01, which were adopted by the Regional Board on December 1, 2006 and August 2, 2007, respectively. These requirements are summarized in Table 9. The water quality monitoring includes influent, secondary effluent, and tertiary effluent. In addition, the monitoring and reporting program includes monitoring of the treatment ponds, secondary storage reservoirs, golf course irrigation lakes, and recycled water use areas. It is anticipated that the monitoring and reporting requirements associated with the future recycled water uses would mirror those required for either the golf courses or the Van Vleck spray field.

Table 9. Summary of Monitoring Requirements

Constituents	Units	Type of Sample	Sampling Frequency	Reporting Frequency
Influent Wastewater Monitoring				
Flow	gpd	Continuous	Daily	Monthly
BOD ₅	mg/L	Grab	Weekly	Monthly
Total Suspended Solids	mg/L	Grab	Weekly	Monthly
Secondary Effluent Monitoring				
BOD ₅	mg/L	Grab	Weekly	Monthly
Total Settleable Solids	mL/L/hr	Grab	Weekly	Monthly
Total Dissolved Solids	mg/L	Grab	Monthly	Monthly
Nitrate (as Nitrogen)	mg/L	Grab	Monthly	Monthly
Ammonia (as Nitrogen)	mg/L	Grab	Monthly	Monthly
Standard Minerals ¹	mg/L	Grab	Annually	Annually
Tertiary Effluent Monitoring				
Flow	gpd	Continuous	Daily	Monthly
Turbidity	NTU	Continuous	Daily	Monthly
Total Chlorine Residual	mg/L	Continuous	Daily	Monthly
Total Coliform Organisms	MPN / 100 mL	Grab	Daily	Monthly
pH	su	Grab	Weekly	Monthly
Total Dissolved Solids	mg/L	Grab	Weekly	Monthly

Sodium	mg/L	Grab	Weekly	Monthly
Chloride	mg/L	Grab	Weekly	Monthly
Nitrates (as Nitrogen)	mg/L	Grab	Monthly	Monthly
Total Kjeldalh Nitrogen	mg/L	Grab	Monthly	Monthly
WWRP Pond Monitoring				
Freeboard	0.1 feet	Measurement	Weekly	Monthly
Dissolved Oxygen	mg/L	Grab	Weekly	Monthly
pH	su	Grab	Weekly	Monthly
North and South Golf Course Monitoring				
Flow to irrigated areas	gpd	Continuous	Daily	Monthly
Rainfall	inches per day	Measurement	Daily	Monthly
Acreage Applied	acres	Calculated	Daily	Monthly
Application Rate	gal/acre/day	Calculated	Daily	Monthly
Total Nitrogen	lbs/month	Calculated	Monthly	Monthly
Total Dissolved Solids (TDS)	lbs/month	Calculated	Monthly	Monthly
Recycled Water Storage Lake Monitoring (Golf Course Lakes)				
Freeboard	feet	Measurement	Weekly	Monthly
Dissolved Oxygen	mg/L	Grab	Weekly	Monthly
pH	su	Grab	Weekly	Monthly
Odors	--	Observation	Daily	Monthly
Van Vleck Ranch Monitoring				
Flow to each reuse area	gpd	Continuous	Daily	Monthly
Rainfall	inches per day	measurement	Daily	Monthly
Acreage Applied	acres	calculated	Daily	Monthly
Nitrogen Loading Rate	lbs/acre-month &	Calculated	Monthly	Monthly
TDS Loading Rate	cumulative lbs/acre-year	Calculated	Monthly	Monthly
Groundwater Monitoring				
Depth to groundwater	0.01 feet	Measurement	Quarterly	Quarterly
Groundwater elevation	0.01 feet	Calculated	Quarterly	Quarterly
Gradient	feet/feet	Calculated	Quarterly	Quarterly
Gradient direction	degrees	Calculated	Quarterly	Quarterly
pH	su	Grab	Quarterly	Quarterly
Total Dissolved Solids	mg/L	Grab	Quarterly	Quarterly
Nitrates (as Nitrogen)	mg/L	Grab	Quarterly	Quarterly
Ammonia (as Nitrogen)	mg/L	Grab	Quarterly	Quarterly
Total Coliform Organisms	MPN/100 mL	Grab	Quarterly	Quarterly
Standard Minerals ²	mg/L	Grab	Quarterly	Quarterly
Metals ³	ug/L	Grab	Quarterly	Quarterly
Total Trihalomethanes	ug/L	Grab	Quarterly	Quarterly

¹ Standard minerals include, at a minimum, the following elements/compounds: pH, boron, bromide, calcium, chloride, fluoride, magnesium, phosphate, potassium, sodium, sulfate, total alkalinity, (including alkalinity series), hardness as CaCO₃, aluminum, arsenic, cadmium, copper, lead, iron, manganese, nickel, and zinc.

² Standard minerals include, at a minimum, the following elements/compounds: pH, boron, bromide, calcium, chloride, fluoride, magnesium, phosphate, potassium, sodium, sulfate, total alkalinity, (including alkalinity series), and hardness as CaCO₃.

³ Metals include, at a minimum, the following elements/compounds: aluminum, arsenic, cadmium, copper, lead, iron, manganese, nickel, and zinc.

The District operates a laboratory on-site, and performs some of the water quality analyses listed above, including chlorine residual, settleable solids, and turbidity. On-line continuous monitoring is conducted for flow, turbidity, and recycled water chlorine residual. The instrumentation used to perform this monitoring is calibrated regularly in accordance with manufacturer's specifications and recommendations. An Environmental Laboratory Accreditation Program (ELAP) Certified Laboratory, utilizing US EPA protocols and methods, performs all other required sample analyses.

2.9 Contingency Plan

The following operational and design features are intended to prevent inadequately treated wastewater (off-specification recycled water) from being delivered to the recycled water user:

- The plant is operated by certified wastewater treatment plant operators. The operators are trained to implement contingency actions when inadequately treated effluent is produced. In addition, the operators utilize operations and maintenance manuals that include standard procedures for responding to alarms that indicate inadequately treated effluent; and
- Applicable design features required by Sections 60333-60355 of the Water Recycling Criteria are provided, as described in Section 2.6.

Should off-specification recycled water be produced at the WWRP, the recycled water pump station will be shut down and off-specification recycled water would not enter the equalization basin or the recycled water distribution system. The following conditions would indicate the possibility that the plant is producing inadequately treated effluent. The presence of any of these turbidity or residual chlorine conditions will result in the automatic shutdown of the recycled water pump station and associated facilities:

- The turbidity of the filtered effluent exceeds 2 NTU; or
- The chlorine residual falls below 5.5 mg/L.

In the event a shutdown is required, an investigation will be conducted to determine the cause of the incident, and the recycled water will not be redirected to the equalization basin until the problem has been corrected and the tertiary effluent is in compliance with the recycled water criteria. If it has not already been shut down by the control system, the manual procedure for ceasing the production of inadequately treated recycled water requires the operator to simply shutdown the recycled water pump station. As noted in Section 2.6, the WWRP has sufficient secondary treatment and storage capacity to contain the wastewater while a system problem is being investigated and corrected.

In the implausible event of off-specification, or inadequately treated recycled water, being conveyed to either existing or future use areas, the Regional Board and CDPH will be notified within 24 hours. A copy of the Recycled Water Contingency and Response Plan is included in

Appendix E and provides direction and guidance to notify the Regional Board and CDPH accordingly.

3.0 Transmission and Distribution Systems

This chapter describes the existing and proposed recycled water transmission and distribution systems.

3.1 Existing Transmission and Distribution Systems

Existing recycled water uses include the two golf courses and the Van Vleck Ranch. The transmission and distribution systems used to convey recycled water to serve these existing uses are shown in *Figure 2*. A recycled water flow diagram of the transmission and storage lakes is shown in *Figure 5*.

3.1.1 North and South Golf Courses

The recycled water transmission and distribution systems associated with the two golf courses were installed in 1983. Since that time, recycled water has been successfully used in accordance with Title 22 and other regulatory requirements to meet golf course irrigation demands. Tertiary treated recycled water is pumped from the 1.8 MG Equalization Basin located at the WWRP to Bass Lake by the Recycled Water Pump Station. Recycled water is conveyed through a 12-inch asbestos cement pipe (ACP) from the WWRP, across Highway 16, over the foot bridge (Yellow Bridge), to the 10th hole of the North Course Golf Course. From this point, the pipeline is reduced to an 8-inch ACP and runs east along the golf course fairways to Bass Lake.

Tertiary treated recycled water is also conveyed from the WWRP to Lake 16 of the South Golf Course by gravity through another 12-inch ACP pipeline. Lakes 16 and 17 of the South Golf Course are interconnected by a culvert. From these lakes, recycled water is pumped to Lakes 10 and 11. The pipeline from Lake 17 to Lake 11 also runs along the golf course fairways and is 8-inch ACP. The pressure rating for all ACP pipelines is 150 psi.

Irrigation pump stations are located adjacent to both Bass Lake and Lake 11. These stations continuously pump the recycled water from the lakes and pressurize the golf course irrigation systems. Multiple pumps are used to meet varying demands, and fertilizer injection systems are also present. The piping material for the irrigation systems is PVC and varies in size from 2- to 6-inch in diameter. The main irrigation distribution pipelines run along the golf course fairways with branches for the sprinkler heads. Irrigation valves are located throughout the golf courses to control the operation of the sprinkler heads. Most valves in the fairways control 3 to 4 sprinklers, while each sprinkler on the greens is generally controlled by individual control valves. Detailed drawings of both the North and South Golf Course distribution and irrigation systems are included in Appendix F.

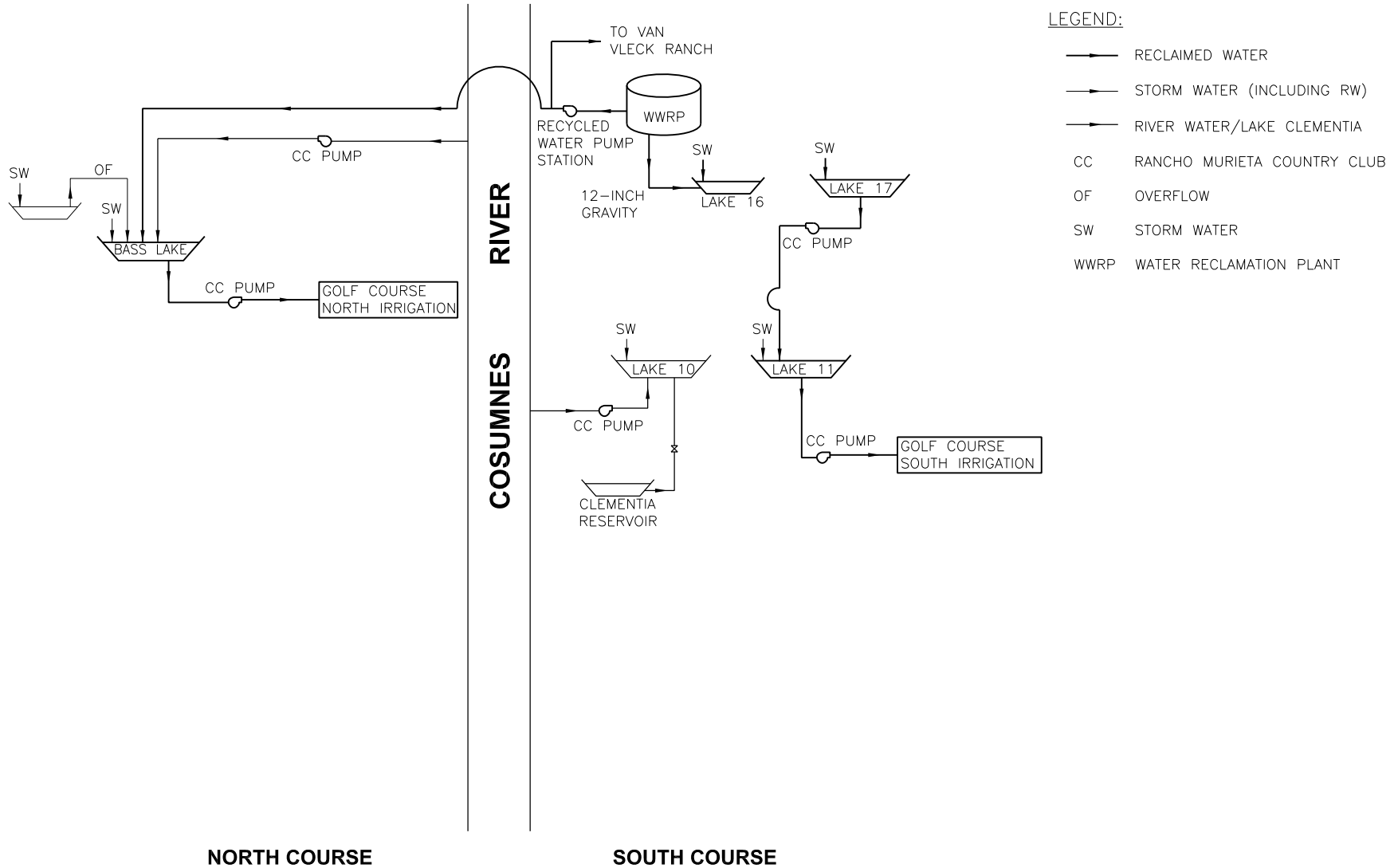

FIGURE 5 - RECYCLED WATER FLOW DIAGRAM

Based on the construction drawings, it appears that a minimum 10-foot separation has been maintained between recycled water and potable water pipelines.² For example there are three pipelines on the Yellow Bridge: sewer, potable water, and recycled water. The sewer and recycled water pipelines are mounted on one side of the bridge, with the potable water on the other side. The District, in association with the RMCC, has developed, submitted, and gained RWQCB approval of an operations manual describing the delivery and use of recycled water at the North and South Golf Courses (May 2010).

3.1.2 Van Vleck Ranch

Approximately 1,800 linear feet of aboveground 12- and 8-inch Certa-Lok™ PVC irrigation pipe is used to convey recycled water to the Van Vleck Ranch boundary and about 4,050 linear feet (LF) of aboveground 8-, 6-, 4-, and 3-inch Certa-Lok™ PVC irrigation pipe is used to convey recycled water to three spray irrigation systems. The 12- and 8-inch PVC pipeline was installed in 2007 and is owned and operated by the District, and has the words “RECYCLED WATER/RECLAIMED WATER” stenciled on top. One of the three existing pumps within Recycled Water Pump Station is used to convey recycled water through the transmission pipeline to three spray fields. There are no potable water or sewer pipelines along the transmission or distribution pipeline alignment.

The distribution system consists of approximately 29 strings of K-line irrigation systems, which are in turn composed of movable sprinklers and 40 mm piping. Each movable sprinkler is housed within a plastic pod. The connecting piping is flexible and the entire string of sprinklers can be moved from spray field to spray field.

The District has developed, submitted, and gained RWQCB approval of an operations and management plan describing the delivery and use of recycled water at the Van Vleck Ranch (August 2007). The District to use the existing aboveground 12- and 8-inch Certa-Lok™ PVC pipeline in the future to serve the existing and proposed spray fields as described later in this report.

3.2 Proposed Transmission Improvements

The recommended improvements for expanding the District recycled water program are shown in Figure 6. Individual improvements would be time-phased into two projects to correspond with development. The following two improvement phases have been established for the addition of recycled water facilities based on the assumed occupancy of Phase 1 and 2 residential developments described in Section 1.3.

- Phase 1 Transmission and Distribution System Improvements: 2015 – 2018
- Phase 2 Transmission and Distribution System Improvements: 2018 – 2022

² South Golf Course Irrigation Systems and North Course Irrigation Systems (Raymond Vail and Associates, February 1983).

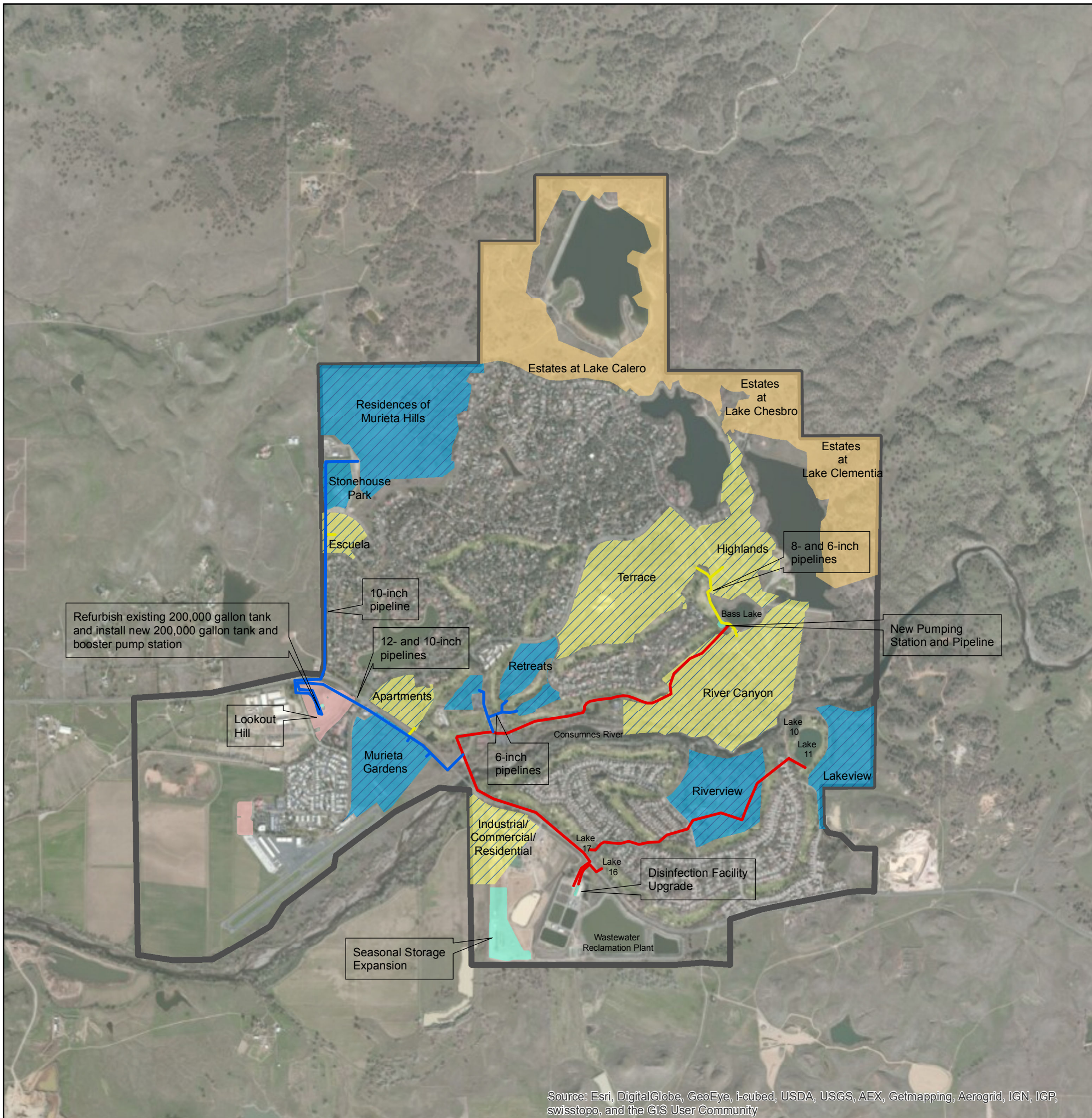

Source: Esri, DigitalGlobe, GeoEye, i-cubed, USDA, USGS, AEX, Getmapping, Aerogrid, IGN, IGP, swisstopo, and the GIS User Community

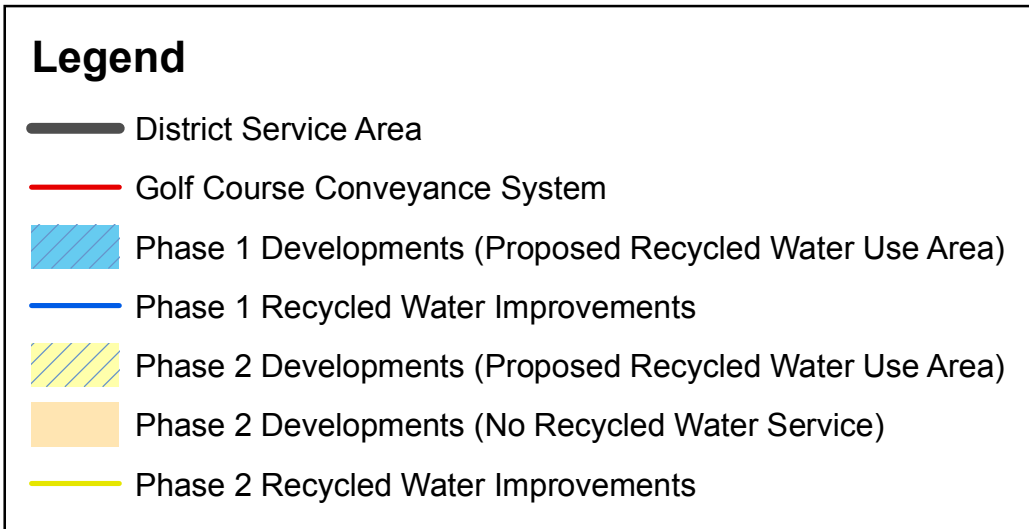
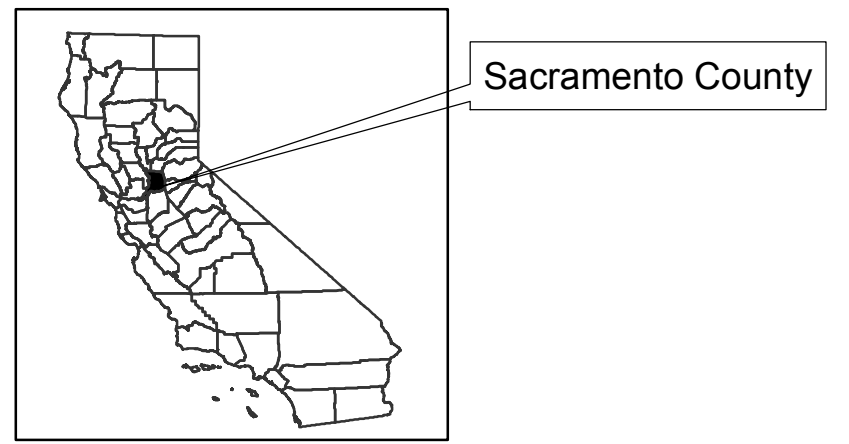
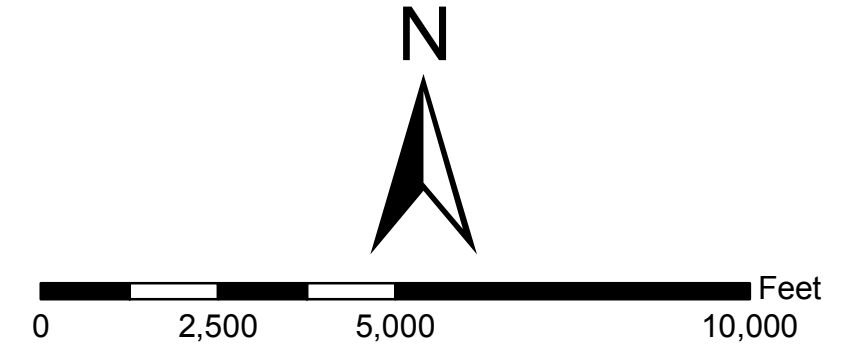

Figure 6. Proposed Recycled Water Transmission and Distribution Improvements

3.2.1 Phase 1 Improvements

The Recycled Water Pump Station is currently configured to pump recycled water to either the North Golf Course or the Van Vleck Ranch. Improvements to this station will be made to (1) separate the functions of this station (one dedicated station for the North Recycled Water Transmission Main and one dedicated for the Van Vleck Ranch) and (2) expand the firm capacity of the station serving the North Recycled Water Transmission Main to approximately 2,110 gpm.³

As shown in Figure 6, a new 12- and 10-inch recycled water transmission main is recommended to serve future developments and Stonehouse Park located along the northwest portion of Rancho Murieta. This particular transmission main will be connected to the existing 12-inch conveyance pipeline immediately north of the Yellow Bridge. Both the highway undercrossing and transmission main up to the point at which the Murieta Gardens development is served shall be a 12-inch pipeline. Beyond this point, the transmission main is reduced to a 10-inch pipeline. Recycled water storage tanks, located at Lookout Hill, are installed to supplement recycled water production during peak irrigation demand seasons. A total of 400,000 gallons of recycled water storage will be provided at this location to satisfy peak irrigation demands. To minimize costs, the District intends to rehabilitate the existing 200,000 gallon water storage tank located on Lookout Hill and use it for recycled water service. In addition, a new 200,000 gallon storage tank will be installed at this site along with a 700 gpm booster pumping station required to deliver recycled water to the developments located in the northwest corner of Rancho Murieta.

A new 6-inch diameter recycled water pipeline will be installed to serve the Retreats, Lakeview, and Riverview developments. As shown in Figure 5, these pipelines will be connected to either the existing 8-inch North Golf Course conveyance pipeline or 8-inch South Golf Course conveyance pipeline. A new pumping station will be installed at Lakes 16/17 to convey recycled water to the Lakeview and Riverview developments then discharge the remaining recycled water into Lakes 10/11. The south recycled water transmission main has adequate capacity to accommodate South Golf Course, Riverview, and Lakeview irrigation demands without significantly impacting Lake 10 and 11 water levels. Therefore, withdrawal of recycled water from Lakes 10 and 11 for residential landscape irrigation will be infrequent.

Recycled water would be routinely transferred through Lakes 16 and 17 in order to serve both the South Golf Course and Riverview and Lakeview residential landscape irrigation demands. It has been estimated that the total combined capacity of these lakes is on the order of 0.9 million gallons. Landscape irrigation demands served by these lakes have been projected to be between 0.5 and 1.1 million gallons per day, which implies a theoretical hydraulic retention time of about one (1) to two (2) days. The District considers this range of detention times to be relatively short and does not anticipate the use of Lakes 16 and 17 to detrimentally impact recycled water quality.

³ The 2,110 gpm flow rate represents the estimated capacity of the existing 12-inch recycled water pipeline serving the North Golf Course.

It should also be understood that the watershed associated with these particular lakes is relatively small (less than 1 acre) and that these lakes are pumped down as much as possible so that minimal amounts of recycled water are in the lakes when the wet season begins in accordance with the *Operations Manual Delivery and Use of Recycled Water at the Rancho Murieta Country Club*, which has been reviewed and approved by the RWQCB. Once the recycled water has been pumped from these lakes, they can either be refilled with raw or potable water or allowed to fill from direct rainfall and runoff during the wet season.

The District has adopted the Recycled Water Standards and the Recycled Water Code. Together, these documents establish and provide the District the ability to enforce rules or regulations for recycled water use and govern the design and construction of recycled water facilities and its use to be in accordance with the uniform statewide reclamation criteria established pursuant to CWC Section 13521.

3.2.2 Phase 2 Improvements

The Phase 2 Improvements consist of installing 8- and 6-inch diameter recycled water pipelines to serve specific developments. As shown in Figure 6, each pipeline shall be connected to the North Recycled Water Transmission Main.

Recycled water for residential landscape irrigation in the north and west regions would be served directly from either the WWRP or the Lookout Hill Recycled Water Tanks under all conditions except for the peak month irrigation season. During this particular 30-day season, approximately 30 percent of the recycled water served to residential customers will be conveyed through Bass Lake. It has been estimated that the total capacity of Bass Lake is on the order of 8.3 MG. During the peak month irrigation season, it is estimated that the daily recycled water demand is on the order of 1.2 MGD, which implies a theoretical hydraulic retention time of seven (7) days. We consider this retention time, coupled with the fact that Bass Lake will be used infrequently as a source of residential landscape recycled water supply, to be relatively short and do not anticipate the use of Bass Lake to detrimentally impact recycled water quality.

As part of their future recycled water operating strategy, the District may elect to maintain a measurable chlorine residual throughout the distribution system (downstream of Bass Lake) when recycled water is withdrawn for residential landscape irrigation purposes. In addition, the District has elected to filter (e.g., through the use of 100 micron filter screens such as those manufactured by Amiad Water Systems) the recycled water withdrawn from Bass Lake prior to distribution for residential landscape irrigation.

4.0 Use Areas

As shown in *Figure 2* existing Use Areas are limited to two (2), eighteen hole golf courses covering approximately 250 acres and pastureland and unimproved areas.

4.1 Irrigation

4.1.1 Golf Course Irrigation (Existing)

Recycled water has been used successfully to irrigate the two eighteen hole golf courses within Rancho Murieta for over 30 years. Currently, the total combined irrigation area and demand of the two golf courses is estimated to be 250 acres and 550 AFY, respectively. Currently recycled water deliveries provide about 455 AFY and the remaining 95 AFY is met through raw water deliveries from the Cosumnes River. Both golf courses are located on sloped topography, both natural and developed. The soils underlying the golf courses are silty; however, the irrigation areas were amended prior to planting.

During the summer months, irrigation demands are high and precipitation is low. The last month of significant irrigation is typically October, but additional irrigation is generally required during the month of November. A summary of historic monthly and annual golf course irrigation demands are summarized in Table 10. As shown, the peak month irrigation demand is approximately 1.9 MGD or roughly 175 acres.

Table 10. Historic Golf Course Irrigation Demands

Month	Irrigation Demand (AF per month) ^a
January	0
February	0
March	0
April	0
May	8
June	123
July	176
August	129
September	96
October	18
November	0
December	0
Total	550

^a Based on 2010 and 2011 golf course irrigation demands records.

Detailed drawings of both golf courses irrigation systems are included in Appendix F.

Wells

There is one well located approximately 400 feet from the golf courses at 7300 Bridge House Lane. This well is used for irrigation purposes only and the District supplies potable water service to this parcel of land.

Containment

Both the North and South Golf Courses have computer controlled irrigation systems. In most areas each control valve operates no more than three sprinkler heads. This allows for precise application of recycled water providing the grass with the proper amount of irrigation without creating puddles or excessive run-off. On the greens, where even more precise control is needed, each sprinkler head is controlled individually. RMCC also uses a remote weather station to track rain and wind magnitudes so that irrigation does not occur during rainy or excessively windy conditions. Throughout the course, quick connections for hose bibs and portable sprinklers are present for manual watering. The following measures are used to minimize run-off and ponding:

- No irrigation is conducted when the weather station detects wind or sustained gusts in excess of 30 miles per hour (mph)
- RMCC staff visually check all areas of the golf courses each morning to ensure optimum application of irrigation, proper operation of sprinkler heads, and identify the presence of ponding.
- Irrigation is not conducted within 24 hours of precipitation.

Setback Distances

The Rancho Murieta golf course community has been designed to merge golf course greenery with the landscaping of the homes located along the courses. As such, setback distances between the golf course irrigation systems and the homes are monitored to prevent the application of recycled water to areas not permitted, such as outdoor eating areas.

Signage

Signs currently used on the golf courses are located at most of the golf course tees, around some of the golf course lakes, and at road crossings. Figure 7 and Figure 8 are photos of the signs currently posted at the tees and lakes, respectively. In addition to the signs, the golf course score cards include a "Do Not Drink" warning and state that recycled water is used to irrigate the golf courses.

Cross Connection Testing

Areas of potential cross connection exist on the golf courses near the restrooms. This is the only potable water service near the recycled water system. Cross-connection testing is conducted every four years in accordance with the procedure described in Appendix D of the Recycled Water Standards. In addition to cross connection testing, reduced pressure, reverse flow protection devices (RP) are installed on the potable water services to the restrooms. This will further protect the public water supply in the event of a cross connection. The RP is installed near the flow meter next to the streets, at the furthest point from the recycled water piping.

Figure 7. Signs Used at Golf Course Tees and Road Crossings



Figure 8. Signs Used at Golf Course Lakes



Irrigation Schedule

All irrigation with recycled water is conducted in the night time hours, approximately between 8:00 p.m. and 6:00 a.m., when public access to the golf courses is not allowed. Both the North and South Golf Courses have computer controlled irrigation systems.

4.1.2 Spray Field Irrigation (Existing)

As shown in Figure 2, the existing spray field use areas, as well as surrounding land use, is limited to pastureland. There are no domestic water distribution systems within this use area for which cross-connection testing would be required. In addition, the spray fields are restricted to the public. Table 11 summarizes the size of the spray fields, estimated annual water demand, type of reuse, and level of access to the public.

The District is responsible for the distribution and use of the recycled water. The application of the recycled water is coordinated with the land manager (Van Vleck Ranch) for necessary grass cuttings or cattle rotation.

Table 11. Existing Irrigation Use Area (Van Vleck Ranch)

User	Use Area (Gross Acres)	Annual Demand (AFY)	Type of Reuse	Method of Application	Land Use	Level of Access
Pastureland (RMCS D)	97	215	Irrigation	Spray	Pastureland	Restricted

The operation of the spray field irrigation system is under the direct supervision of a RMCS D Certified Wastewater Operator. The Operator is responsible for monitoring the use areas for potential ponding or runoff of recycled water. To minimize the potential impacts, there is no irrigation of pastureland:

- Within 24 hours of anticipated precipitation (greater than 50 percent chance of rain);
- Within 24 hours after measurable precipitation (greater than 0.10 inches); or
- If sustained wind speeds exceed 30 mph.

The District currently uses a rain gauge for measuring precipitation at the WWRP. A weather station owned and operated by the RMCC is used to determine wind speeds.

Wells

There are four groundwater wells located within 1,000 feet of the spray fields. These wells, located north of the spray fields, are not used for potable or nonpotable water uses. Rather, these wells are strictly used by the District to monitor groundwater quality underneath the District’s WWRP.

Containment

The spray fields are inspected throughout the day when the recycled water irrigation system is in operation and the pasturelands are being irrigated with recycled water so that the potential

occurrence of ponding or tail water is minimized. These particular spray fields were originally designed for flood irrigation. Therefore, each spray field drains to a common point for immediate visual inspection of tail water migration. The typical direction of drainage is shown in *Figure 2*.

Setback Distances

The spray fields are not located near residential homes, drinking water fountains, outdoor eating, or picnic areas. Thus, no set-back distances are required. However, a minimum of 50 feet from the property boundary is provided. In addition, signs are posted at regular intervals even though the spray fields are located within restricted areas, with no public access. The spray fields are located within a gated area with the District's WWRP between the use areas and any potential public access point (Highway 16). Further, an existing three-strand barbed wire fence surrounds each spray field.

Signage

Although public access is not allowed, signs are posted along each spray field parameter to notify operators and land use personnel regarding the use of recycled water for irrigation purposes on the pastureland. In general, signs are located along the boundary of each spray field, at all access points, and at other locations necessary for notifications.

Irrigation Schedule

The spray fields are irrigated with recycled water between the hours of 6:00 a.m. and 6:00 p.m., during normal District operating hours. The spray fields are only operated when an operator is on-site and can visually inspect the spray fields.

4.1.3 Proposed Irrigation

As described in Section 1.3.3 of the Recycled Water Standards, each use area must obtain a Recycled Water Permit prior to receiving recycled water from the District. A description of the required procedures for obtaining a Recycled Water Permit for irrigation uses, which includes the preparation of a Recycled Water Plan, is provided in Section 1.3.4 of the Recycled Water Standards.

The District proposes to serve recycled water within its service area for the irrigation of parks, greenbelts, and playgrounds; athletic fields; common areas; commercial landscaping; freeway, highway, and street landscaping; and dust control. The use of recycled water for these purposes is governed by the Recycled Water Standards and Recycled Water Code. The use of recycled water for these irrigation uses shall conform to the following requirements:

- Not cause a pollution or nuisance as defined by Section 13050 of the CWC.
- Not cause degradation of any water supply
- Be managed in conformance with the regulations contained in Title 22, Division 4, Chapter 3, CCR

- All recycled water equipment, pumps, piping, valves, and outlets shall be appropriately marked to differentiate them from potable water facilities. All recycled water distribution system piping shall be purple or adequately wrapped with purple tape.
- Perimeter warning signs indicating that recycled water is in use shall be posted as prescribed in the User's Recycled Water Plan that is subject to approval by the District.
- Recycled water shall not be allowed to escape from the authorized use areas by airborne spray or by surface flow except in minor amounts such as that associated with good irrigation practices.
- There shall be at least a ten foot horizontal and one foot vertical separation at crossings between all pipelines transporting recycled water and those transporting potable water, with potable water above the recycled water pipeline. Unless otherwise approved by the District.
- There shall be no cross connection between the potable and recycled water supply and piping. Supplementing recycled water with potable water shall not be allowed except through an air-gap separation.
- Areas irrigated with recycled water shall be managed to prevent ponding and conditions conducive to the proliferation of mosquitoes and other disease vectors, and to avoid creation of a public nuisance or health hazard. The following practices shall be implemented, at a minimum:
 - Irrigation water must infiltrate within a 48-hour period.
 - Landscape irrigation facilities shall be designed and operated for watering periods that minimize the potential for human contact. Spray irrigation shall generally operate between the hours of 10:00 p.m. and 6:00 a.m. Drip irrigation systems may operate at any time.
 - Ditches receiving irrigation runoff, not serving as wildlife habitat, shall be maintained free of emergent, marginal, and floating vegetation.
 - Low-pressure and unpressurized pipelines and ditches accessible to mosquitoes shall not be used to store recycled water.
- No hose bibs are allowed to connect to the recycled water system.

4.2 Impoundments

4.2.1 Existing Impoundments

Irrigation pump stations are located adjacent to (or within) Bass Lake and Lake 11. These stations pump the recycled water from the lakes and pressurize the golf course irrigation systems. Multiple pumps are used to meet the varying golf course irrigation demands.

4.2.2 Proposed Impoundments

A new pumping station will be installed at Lakes 16/17 to convey recycled water to the Lakeview and Riverview developments then discharge the remaining recycled water into Lakes 10/11. The south recycled water transmission main has adequate capacity to accommodate South Golf Course, Riverview, and Lakeview irrigation demands without significantly impacting Lake 10 and 11 water levels. Therefore, withdrawal of recycled water from Lakes 10 and 11 for residential landscape irrigation will be infrequent.

Recycled water would be routinely transferred through Lakes 16 and 17 in order to serve both the South Golf Course and Riverview and Lakeview residential landscape irrigation demands. It has been estimated that the total combined capacity of these lakes is on the order of 0.9 MG. Landscape irrigation demands served by these lakes have been projected to be between 0.5 and 1.1 MGD, which implies a theoretical hydraulic retention time of about one (1) to two (2) days. The District considers this range of detention times to be relatively short and does not anticipate the use of Lakes 16 and 17 to detrimentally impact recycled water quality.

The watershed associated with Lakes 16 and 17 is relatively small (less than 1 acre). In addition these lakes are pumped down as much as possible so that minimal amounts of recycled water are in the lakes when the wet season begins in accordance with the *Operations Manual Delivery and Use of Recycled Water at the Rancho Murieta Country Club*. Once the recycled water has been pumped from these lakes, they can either be refilled with raw or potable water or allowed to fill from direct rainfall and runoff during the wet season.

Recycled water for residential landscape irrigation in the north and west regions would be served directly from either the WWRP or the Lookout Hill Recycled Water Tanks under all conditions except for the peak month irrigation season. During this particular 30-day season, approximately 30 percent of the recycled water served to residential customers will be conveyed through Bass Lake. It has been estimated that the total capacity of Bass Lake is on the order of 8.3 MG. During the peak month irrigation season, it is estimated that the daily recycled water demand is on the order 1.2 MGD, which implies a theoretical hydraulic retention time of seven (7) days. We consider this retention time, coupled with the fact that Bass Lake will be used infrequently as a source of residential landscape recycled water supply, to be relatively short and do not anticipate the use of Bass Lake to detrimentally impact recycled water quality.

As part of their future recycled water operating strategy, the District may elect to maintain a measurable chlorine residual throughout the distribution system (downstream of Bass Lake) when recycled water is withdrawn for residential landscape irrigation purposes. In addition, the District has elected to filter (e.g., through the use of 100 micron filter screens such as those manufactured by Amiad Water Systems) the recycled water withdrawn from Bass Lake prior to distribution for residential landscape irrigation.

4.3 Cooling

Not Applicable

4.4 Groundwater Recharge

Not Applicable

4.5 Dual Plumbed Use Areas

4.5.1 Existing Dual Plumbed Use Areas

Not Applicable

4.5.2 Proposed Dual Plumbed Use Areas

The requirements associated with the use of recycled water for residential landscape irrigation are contained in Section 2.2 of the Recycled Water Standards. As described in 2.2.11.3 of the Recycled Water Standards, the following information shall be submitted to the District as part of an applicant's Recycled Water Plan:

- A detailed description of the intended use area identifying the following:
 - The number, location, and type of facilities within the use area proposed to use recycled water for residential landscape irrigation,
 - The average number of persons estimated to be served by each facility on a daily basis,
 - The specific boundaries of the proposed use area including a map showing the location of each facility to be served,
 - The Site Supervisor responsible for the operation and maintenance of the residential recycled water landscape irrigation system, and
 - The specific use of recycled water at the use area.
- Each Recycled Water Plan shall describe the following:
 - Proposed piping systems to be used. Piping system shall be in compliance with the materials described in Section 2.2. 5 of the Recycled Water Standards.
 - Pipe locations of both the recycled and potable water systems as described in Section 2.2.11.3 of the Recycled Water Standards.
 - Type and locations of outlets and plumbing fixtures that will be accessible to the public. As described in Note 8 of Section 2.2.11.3.4, there shall be no hose bibs or quick connectors on the recycled water system.

- The methods and devices to be used to prevent backflow of recycled water into the public water system (see Recycled Water Standard Detail RW-27).

The District shall conduct the following testing and inspections specific to residential landscape irrigation as described in Section 1.9 of the Recycled Water Standards:

- a. Cross-Connection testing prior to receiving recycled water and every four (4) years thereafter, or at change of ownership.
- b. Backflow prevention device testing shall be conducted prior to receiving recycled water service and annually thereafter.
- c. Coverage testing shall be performed prior to receiving recycled water and annual thereafter. Coverage testing shall be conducted by the District's inspector to verify that the Site Supervisor certification is current, that the potable and recycled water systems have not been significantly modified, and that the irrigation system is being operated and maintained in the proper manner and that overspray, ponding, and runoff are being controlled.

The District shall notify the CDPH of any incidence of backflow from the residential landscape irrigation system into the potable water system within 24 hours of the discovery of the incident.

4.6 Other Uses

4.6.1 Other Existing Uses

Not Applicable

4.6.2 Dust Control

The California Code of Regulations, Title 22 Section 60307(b) (6) allows for the use of recycled water for dust control on streets and roads. The District has prepared a Dust Control Guideline to support the use this proposed use (see Appendix G). As described in this guidelines, vehicles used for collecting and distributing recycled water for dust control shall:

- Have an adequate tank and plumbing system to ensure that leaks and ruptures will not occur due to normal use.
- Be equipped with either two risers, one for potable water and one for recycled water, or each tank used shall be equipped with a District-approved air-gap separation between the filler tube and the tank.
- Have color-coded risers, hoses, and fittings; blue for potable water and purple for recycled water.

- Be equipped with uniquely sized fittings to prevent accidental connection between the potable water and recycled water systems.
- Be equipped with spray heads/nozzles configured to minimize runoff, ponding, and drift.
- Be equipped with control valves configured such that recycled water can be applied in a controlled fashion on the site and completely retained during transit.
- Be clearly labeled as specified in the “Signage Requirements.”
- Prior to use, the District will inspect the Users’ vehicles to ensure compliance with the requirements listed above.
- Each vehicle tank used to store and/or transport recycled water must be flushed and disinfected prior to storage and/or transport of potable water or recycled water of higher quality.
- User must maintain a log recording details of all recycled water deliveries (date, location, volume, and end use).
- Any storage facility containing recycled water for reuse applications shall be managed in a manner to control odor.
- Sites shall be designed and operated using Best Management Practices (BMPs) as stated below, or as revised by the District to prevent recycled water spray, mist, or surface flow from either leaving the site or reaching:
 1. Any storm drain or surface water with year-round flow located adjacent to the site;
 2. Areas with public access (e.g., dwellings, designated outdoor eating areas, or food handling facilities); and
 3. Drinking fountains, unless specifically protected with a shielding device.

4.7 Use Area Design

Sections 2 and 3 of the Recycled Water Standards describe how the domestic potable water distribution system shall be protected from recycled water in accordance with regulations relating to cross-connections and the California Waterworks Standards. In addition, these sections describe how the recycled water facilities shall be designed to minimize the potential for recycled water leaving a designated use area.

4.8 Use Area Inspection and Monitoring

4.8.1 Existing Spray Field (Van Vleck Ranch)

Monitoring and reporting requirements specific to the Van Vleck Ranch are contained in WDR R5-2007-0109. In addition, District operators visually monitor the spray fields on a daily basis during the application of recycled water for run-off, ponding, or over spray. As part of the daily visual inspection, each spray field that was irrigated is assessed for ponding. In addition, each low point of the spray field is visually inspected for potential run-off from the designated use areas.

4.8.2 Existing Golf Courses

Monitoring and reporting requirements for the use of recycled water for golf course irrigation are contained in WDR 5-01-124 and in Section 4 of the *Delivery and Use of Recycled Water at the Rancho Murieta Country Club* (May 2010). As described in the later document, RMCC staff monitors the recycled water storage lakes (e.g., Bass Lake, and Lakes 10, 11, 16, and 17) and golf course irrigation to ensure that excessive runoff or ponding is not occurring.

4.8.3 Proposed Use Areas and Landscape Irrigation Uses

Proposed District monitoring and inspection activities for the expanded recycled water program include:

- As the Producer, recycled water quality characteristics shall be routinely monitored by the District,
- As the overall administrator, the District shall monitor recycled water production, distribution, and use within its service area for each respective development and/or use area:
 - Volume of recycled water (acre-feet),
 - Total number of use areas per development,
 - Total area of application (acres),
 - Nitrogen application rate (lb/acre-month), and
 - Salinity application rate (lb/acre-month).

Monitor sampling shall occur on a monthly basis whereas reporting to the RWQCB shall occur on an annual basis.

- Each month the District shall verify that the recycled water has been filtered and disinfected consistent with criteria for disinfected tertiary recycled water. The District shall continuously track turbidity and disinfection parameters.⁴ Exceedances of turbidity or disinfection standards shall be documented and explained.⁵
- The District shall retain records of all monitoring information including all calibration and maintenance records and copies of all pertinent reports. Records shall be maintained for a minimum of three years from the date of sampling, measurement, or submission. This period may be extended during the course of any unresolved investigation or litigation regarding the recycled water operation or when requested by the Executive Officer of the RWQCB.
- The District shall report priority pollutants to the RWQCB semiannually, in accordance with paragraph 7(b) (4) of the Recycled Water Policy.

Administrator Reporting

- The District shall compile information for each development and/or use area within its service area and annually submit the compilation to the RWQCB. The compilation shall also contain the following items:
 - Summary and discussion of the compliance record for the reporting period. If violations have occurred, the report shall also discuss the corrective actions taken and plans to bring the discharge into full compliance with the WDR and MRP, and
 - A description of the measures employed by the District during the reporting period to conduct periodic inspections of the developments and/or Use Areas. The description shall include the following elements: date of inspections, description of any violations identified during the reporting period including any indications of unauthorized cross-connections, and all actions taken or planned for correcting violations, such as operation or facility modifications.

Periodic inspections shall also include an evaluation verifying that the application of recycled water to the developments and Use Areas occurs at reasonable agronomic rates. The agronomic rate evaluation shall consider all applied nutrients demand from all sources (directly applied and as contained in the recycled water) the seasonal nutrient demand for the specific plants being grown, soil, and climate. If the agronomic rate evaluation determines that exceedances of the agronomic rates may be occurring, the District shall implement corrective actions to ensure recycled water use occurs at reasonable agronomic rates. If the District has previously submitted a report describing corrective actions and/or a time schedule for implementing the corrective actions, reference to the previous correspondence will be satisfactory.

- A description of approved amendments to the Title 22 Engineering Report, if any.

⁴ Nephelometric Turbidity Units (NTU), chlorine residual (mg-L), and CT (mg-min/L).

⁵ Title 22, Sections 60301.320, 60301.230 (a), and 60301.230 (b)

- A description of the new Use Areas approved by the CDPH. The description shall include information necessary for the CDPH to evaluate proposed Use Areas pursuant to the Title 22 Requirements. Examples of necessary information may include location of backflow prevention devices, drinking fountains, groundwater wells, etc.
- Copies of approved letter(s) prepared by CDPH regarding such amendments to the Title 22 Engineering Report.

All reports submitted to the RWQCB shall comply with the signatory requirements. Monitoring data and/or discussions submitted concerning WWRP performance must also be signed and certified by the District's Director of Field Operations.

Spill Reporting

The District shall ensure that RMCC, or any other Distributor, reports any noncompliance that may endanger human health or the environment. The District shall immediately report orally or electronically if available, information of the noncompliance as soon as (1) the District has knowledge of the discharge, (2) notification is possible, and (3) notification can be provided without substantially impeding cleanup or other emergency measures, to the RWQCB.

A written report shall also be provided to the RWQCB within five (5) business days of the time the District becomes aware of the incident. The written report shall contain a description of the noncompliance and its cause, the period of noncompliance, the anticipated time to achieve full compliance, and the steps taken or planned, to reduce, eliminate, and prevent recurrence of the noncompliance.

The unauthorized discharge of 50,000 gallons or more of disinfected tertiary recycled water shall be reported. The unauthorized discharge of 1,000 gallons or more of disinfected tertiary recycled water shall be reported to the RWQCB as soon as possible, but no later than seventy-two (72) hours after becoming aware of the unauthorized discharge.

All application reports or information to be submitted to the RWQCB shall be signed and certified by the District's General Manager and shall make the following certification:

I declare under the penalty of law that I have personally examined and am familiar with the information submitted in this document, and that based on my inquiry of those individuals immediately responsible for obtaining the information. I believe that the information is true, accurate, and complete. I am aware that there are significant penalties for submitting false information, including the possibility of a fine and imprisonment for knowing violations.

4.9 Employee Training

4.9.1 District Training

District employees are certified wastewater operators trained and educated in the treatment, distribution, and use of wastewater and recycled water. Recycled water production and use training for the District operators is conducted annually prior to the startup of the tertiary treatment processes in March for irrigation of the two golf courses. The training provided at that time is applicable to all of the recycled water uses proposed by the District.

4.9.2 RMCC Training

Training is given to all employees of the RMCC who work or may come in contact with the recycled water system. Golf course employees participate in group training sessions which include at a minimum the following elements:

- Recycled water use regulations and guidelines including avoidance of bodily contact and acceptable uses of recycled water;
- Golf course irrigation inspection procedures including the identification and communication process for alerting technicians of areas with ponding, excessive run-off, or over spray outside of irrigation areas; and
- Golf course technicians are providing training in sprinkler adjustment with emphasis on minimizing recycled water contact with residential areas, and the prevention of ponding and/or excessive run-off.

4.9.3 Site Supervisor Training

All potential recycled water use area customers are required to have a designated Site Supervisor. Specific Site Supervisor requirements are to:

- Receiving training by attending a District-sponsored Recycled Water Orientation or be able to demonstrate knowledge of the application and maintenance of recycled water systems.
- Be aware and familiar with the District's Recycled Water Standards.
- Be knowledgeable about the practices and procedures of using recycled water.
- Be available to the District and have the authority to carry out any requirements of the District relating to their recycled water irrigation system.

The Recycled Water Orientation will be designed to explain the District's recycled water guidelines, uses, requirements, and the process by which recycled water service can be obtained. Potential recycled water customers, as well as Recycled Water Plan designers and

contractors working in dual-plumbed developments, are required to attend a District orientation. All designers and contractors are required to attend the orientation every 24 months.

A schedule of the upcoming Recycled Water Orientations will be posted on the District's website.

Appendix A – Contact List

Contact Agencies and Information

Rancho Murieta Community Services District

Paul Siebensohn, Director of Field Operations

Phone No: (916) 354-3730

Fax No: (916) 354-2082

Email: psiebensohn@ranchomurietacsd.com

Edward Crouse, General Manager

Phone No: (916) 354-3700

Fax No: (916) 354-2082

Email: ecrouse@ranchomurietacsd.com

Regional Water Quality Control Board, Central Valley

Phone No: (916) 464-3291

Fax No: (916) 464-4645

Address: 11020 Sun Center Drive #200
Rancho Cordova, CA 95670-6114

California Department of Public Health, Sacramento District

Phone No: (916) 449-5600

Fax No: (916) 449-5655

Address: 1616 Capital Avenue
PO Box 997377, MS 7407
Sacramento, CA 95899-7377

Appendix B – Recycled Water Standards

Appendix C – Recycled Water Code

Appendix D – Water Balances

Rancho Murieta Community Services District
Water Balance - Buildout Condition

	Units	100-yr Level of Annual Precipitation												Average Level of Annual Precipitation													
		October	November	December	January	February	March	April	May	June	July	August	September	Total	October	November	December	January	February	March	April	May	June	July	August	September	Total
Climate Inputs																											
Precipitation (Average)	in	1.32	3.47	3.39	4.46	4.34	4.30	1.84	0.52	0.31	0.11	0.10	0.45	24.61	1.32	3.47	3.39	4.46	4.34	4.30	1.84	0.52	0.31	0.11	0.10	0.45	24.61
Precipitation (100-YR)	in	2.43	6.38	6.24	8.21	7.99	7.91	3.39	0.96	0.57	0.20	0.18	0.83	45.28	2.43	6.38	6.24	8.21	7.99	7.91	3.39	0.96	0.57	0.20	0.18	0.83	45.28
Pan Evaporation	in	4.89	2.06	1.25	0.92	1.90	3.47	5.21	8.07	9.91	11.12	9.93	7.45	66.18	4.89	2.06	1.25	0.92	1.90	3.47	5.21	8.07	9.91	11.12	9.93	7.45	66.18
Effective Lake Evaporation	in	3.67	1.55	0.94	0.69	1.43	2.60	3.91	6.05	7.43	8.34	7.45	5.59	49.64	3.67	1.55	0.94	0.69	1.43	2.60	3.91	6.05	7.43	8.34	7.45	5.59	49.64
Lake Evap - 100-yr Effective	in	3.67	1.55	0.75	0.55	1.14	2.08	3.13	6.05	7.43	8.34	7.45	5.59	47.72	3.67	1.55	0.75	0.55	1.14	2.08	3.13	6.05	7.43	8.34	7.45	5.59	47.72
Percolation	in	0.00	0.00	0.00	0.00	0.00	0.00	0.00	0.00	0.00	0.00	0.00	0.00	0.00	0.00	0.00	0.00	0.00	0.00	0.00	0.00	0.00	0.00	0.00	0.00	0.00	0.00
RMCS D WWRP																											
WW Influent - Monthly-Daily Flow	%	8%	8%	10%	9%	8%	10%	9%	8%	8%	8%	8%	7%	100%	8%	8%	10%	9%	8%	8%	8%	7%	7%	7%	7%	7%	100%
# Days in Month	days	31	30	31	31	28	31	30	31	30	31	31	30	365	31	30	31	31	28	31	30	31	30	31	30	365	
Wastewater Influent	MG	28.7	28.3	34.7	31.9	28.1	35.7	32.0	30.1	27.8	28.2	28.1	26.9	360.50	28.7	28.3	34.7	31.9	28.1	35.7	32.0	30.1	27.8	28.2	28.1	26.9	360.50
Wastewater Influent	ac-ft	88.0	86.7	106.6	98.0	86.3	109.6	98.1	92.4	85.3	86.7	86.3	82.5	1106.35	88.0	86.7	106.6	98.0	86.3	109.6	98.1	92.4	85.3	86.7	86.3	82.5	1106.35
100-YR I/I Estimate	ac-ft	7.7	7.6	9.3	8.5	7.5	9.5	8.5	8.0	7.4	7.5	7.5	7.2	96.36	7.7	7.6	9.3	8.5	7.5	9.5	8.5	8.0	7.4	7.5	7.5	7.2	96.36
Site Run-off	ac-ft	1.9	5.1	5.0	6.6	6.4	6.3	2.7	0.8	0.5	0.2	0.1	0.7	36.34	1.9	5.1	5.0	6.6	6.4	6.3	2.7	0.8	0.5	0.2	0.1	0.7	36.34
Pond Precipitation (direct)	ac-ft	2.2	5.7	5.6	7.3	7.1	7.1	3.0	0.9	0.5	0.2	0.2	0.7	40.38	2.2	5.7	5.6	7.3	7.1	7.1	3.0	0.9	0.5	0.2	0.2	0.7	40.38
Pond Evaporation	ac-ft	-3.3	-1.4	-0.8	-0.6	-1.3	-2.3	-3.5	-5.4	-6.6	-7.4	-6.6	-5.0	-44.26	-3.3	-1.4	-0.8	-0.6	-1.3	-2.3	-3.5	-5.4	-6.6	-7.4	-6.6	-5.0	-44.26
RMCS D Secondary Storage Reservoirs																											
Reservoir # 1 Vol	ac-ft	36.5	85.9	188.0	308.6	432.0	541.4	665.4	729.8	720.0	610.6	441.2	319.8	5079.19	36.5	85.9	188.0	308.6	432.0	541.4	665.4	729.8	720.0	610.6	441.2	319.8	5079.19
Reservoir # 1 Depth	ft	5.2	8.2	14.0	20.0	25.3	29.2	32.8	34.3	34.1	31.3	25.7	20.6	280.80	5.2	8.2	14.0	20.0	25.3	29.2	32.8	34.3	34.1	31.3	25.7	20.6	280.80
Reservoir # 1 Surface Area	acre	18.5	19.5	21.5	23.5	25.3	26.6	27.9	28.4	28.3	27.4	25.4	23.7	295.83	18.5	19.5	21.5	23.5	25.3	26.6	27.9	28.4	28.3	27.4	25.4	23.7	295.83
Reservoir # 2 Vol	ac-ft	8.6	20.1	44.1	72.4	101.3	127.0	156.1	171.2	168.9	143.2	103.5	75.0	1191.41	8.6	20.1	44.1	72.4	101.3	127.0	156.1	171.2	168.9	143.2	103.5	75.0	1191.41
Reservoir # 2 Depth	ft	3.6	6.8	12.8	19.0	24.4	28.3	31.8	33.2	33.0	30.4	24.7	19.5	267.51	3.6	6.8	12.8	19.0	24.4	28.3	31.8	33.2	33.0	30.4	24.7	19.5	267.51
Reservoir # 2 Surface Area	acre	3.3	3.7	4.5	5.4	6.2	6.7	7.2	7.4	7.4	7.0	6.2	5.5	70.48	3.3	3.7	4.5	5.4	6.2	6.7	7.2	7.4	7.4	7.0	6.2	5.5	70.48
Total Water Surface Area	acre	21.7	23.2	26.0	28.9	31.5	33.3	35.0	35.8	35.7	34.4	31.6	29.2	366.31	21.7	23.2	26.0	28.9	31.5	33.3	35.0	35.8	35.7	34.4	31.6	29.2	366.31
Contributing Water Shed Area	acre	18.3	16.8	14.0	11.1	8.5	6.7	5.0	4.2	4.3	5.6	8.4	10.8	113.69	18.3	16.8	14.0	11.1	8.5	6.7	5.0	4.2	4.3	5.6	8.4	10.8	113.69
Reservoir Run-off	ac-ft	3.3	8.0	6.5	6.8	5.1	3.9	1.3	0.3	0.2	0.1	0.1	0.7	36.41	3.3	8.0	6.5	6.8	5.1	3.9	1.3	0.3	0.2	0.1	0.1	0.7	36.41
Reservoir Precip (direct)	ac-ft	4.4	12.3	13.5	19.8	20.9	22.0	9.9	2.9	1.7	0.6	0.5	2.0	110.49	4.4	12.3	13.5	19.8	20.9	22.0	9.9	2.9	1.7	0.6	0.5	2.0	110.49
Reservoir Evaporation	ac-ft	-6.6	-3.0	-2.0	-1.7	-3.7	-7.2	-11.4	-18.0	-22.1	-23.9	-19.6	-13.6	-132.92	-6.6	-3.0	-2.0	-1.7	-3.7	-7.2	-11.4	-18.0	-22.1	-23.9	-19.6	-13.6	-132.92
RMCC Irrigation Lakes																											
Lake Water Shed Run-off	ac-ft	0.2	0.4	0.4	0.5	0.5	0.5	0.2	0.1	0.0	0.0	0.0	0.1	2.81	0.2	0.4	0.4	0.5	0.5	0.5	0.2	0.1	0.0	0.0	0.1	2.81	
Lake Precipitation (direct)	ac-ft	2.3	6.0	5.8	7.7	7.5	7.4	3.2	0.9	0.5	0.2	0.2	0.8	42.41	2.3	6.0	5.8	7.7	7.5	7.4	3.2	0.9	0.5	0.2	0.2	0.8	42.41
Irrig. Lake Evaporation	ac-ft	-3.4	-1.4	-0.9	-0.6	-1.3	-2.4	-3.7	-5.7	-7.0	-7.8	-7.0	-5.2	-46.49	-3.4	-1.4	-0.9	-0.6	-1.3	-2.4	-3.7	-5.7	-7.0	-7.8	-7.0	-5.2	-46.49
Supplemental Water																											
Supplemental Water	ac-ft	0.0	0.0	0.0	0.0	0.0	0.0	0.0	0.0	0.0	0.0	0.0	0.0	0.00	0.0	0.0	0.0	0.0	0.0	0.0	0.0	0.0	0.0	0.0	0.0	0.0	0.00
Disposal																											
RMCC Golf Course Demand	ac-ft	-20.3	0.0	0.0	0.0	0.0	-0.8	-16.4	-50.8	-111.4	-151.3	-120.5	-78.5	-550.00	-20.3	0.0	0.0	0.0	0.0	-0.8	-16.4	-50.8	-111.4	-151.3	-120.5	-78.5	-550.00
Residential Irrigation	ac-ft	-15.3	0.0	0.0	0.0	0.0	-0.6	-12.3	-38.4	-84.1	-114.1	-91.0	-59.2	-415.00	-15.3	0.0	0.0	0.0	0.0	-0.6	-12.3	-38.4	-84.1	-114.1	-91.0	-59.2	-415.00
Van Vleck Ranch Demand	ac-ft	0.0	0.0	0.0	0.0	0.0	0.0	0.0	0.0	0.0	0.0	0.0	0.0	0.00	0.0	0.0	0.0	0.0	0.0	0.0	0.0	0.0	0.0	0.0	0.0	0.0	0.00
Effluent Storage																											
Beginning Water Volume in Res.	ac-ft	45	106.0	232.0	381.0	533.3	668.3	821.4	901.0	888.9	753.9	544.8	394.9	6270.60	45	106.0	232.0	381.0	533.3	668.3	821.4	901.0	888.9	753.9	544.8	394.9	6270.60
Change in Water Volume	ac-ft	61.0	126.0	149.0	152.3	135.0	153.1	79.6	-12.1	-135.0	-209.1	-149.9	-67.0	282.88	61.0	126.0	149.0	152.3	135.0	153.1	79.6	-12.1	-135.0	-209.1	-149.9	-67.0	282.88
Final Water Volume in Reservoirs	ac-ft	106.0	232.0	381.0	533.3	668.3	821.4	901.0	888.9	753.9	544.8	394.9	327.9	6553.48	106.0	232.0	381.0	533.3	668.3	821.4	901.0	888.9	753.9	544.8	394.9	327.9	6553.48

Appendix E – Recycled Water Contingency and Response Plan

Reclaimed Water Contingency and Response Plan

For

**Rancho Murieta
Community
Services District**

**Revised: October 21, 2013
Contact: Paul Siebensohn
(916) 354-3712**

Table of Contents

Overview	3
Staffing	3
Equipment	3
Prevention	3
Effluent Exceeding Limitation Response	4
Effluent Exceeding Limitation Notification and Reporting	5
Effluent Exceeding Limitation Response Evaluation	7
Post-Spill Assessment	11

Overview

This plan will serve as an outline for the response of District employees if a tertiary treatment limit is exceeded or if there is an overflow of one of the reclaimed water storage ponds at the Rancho Murieta Reclamation Facility.

Tertiary Plant's Discharge Limits

See Waste Discharge Requirements (WDRs) Order No. R5-2007-0109. General information from it is as follows; The median concentration of total coliform bacteria measured in the disinfected effluent shall not exceed an MPN of 2.2 per 100 milliliters utilizing the bacteriological result of the last seven days for which analyses have been completed and the number of total coliform bacteria shall not exceed an MPN of 23 per 100 milliliters in more than one sample in any 30 day period.

No sample shall exceed an MPN of 240 total Coliform bacteria per 100 milliliters.

The turbidity of the filter effluent shall not exceed 2.0 NTU as a daily average; shall not exceed 5 NTU more than 5 percent of the time during a 24 hour period; and shall never exceed 10 NTU.

RMCS D may not discharge reclaimed water 24 hours before or after any precipitation, or when soils are saturated.

pH levels must be between 6.5 and 9.0 and maintain a D.O. level of 1 mg/L.

Staffing

The District's operators work Monday thru Friday from 0700 to 1600 hours and one operator works Saturday and Sunday from 0700 to 1600. There is one utility worker and operator that is on call after normal working hours.

Name	Title	Cell Phone	Office
Paul Siebensohn	Director of Field Operations	On file	(916)354-3700
David Herrmann	Chief Plant Operator	On file	(916)354-3700
Sean Montgomery	Plant Operator	On file	(916)354-3700
Jason Dill	Equipment Mechanic	On file	(916)354-3700
Travis Bohannon	Plant Operator	On file	(916)354-3700
Mike Miller	Plant Operator	On file	(916)354-3700
Cory Xavier	Plant Operator	On file	(916)354-3700
Rob McLeod	Utility Supervisor	On file	(916)354-3700

Monitoring Equipment

A chlorine analyzer, pH meter and a turbidimeter monitor the tertiary effluent at the end of the contact chamber. The chlorine analyzer or the turbidimeter instruments will shut down the tertiary plant if the water is out of the monitored parameter. All of these instruments are checked daily for calibration. The water elevation in the equalization basin will cause the tertiary plant to shut down when the basin fills to a set level. There are contacts in Lake 17 that operates the valve separating Lake 16 and the equalization basin, as well as a high float switch that will alarm out as well as shut down the plant.

Prevention

The chlorine analyzer, pH meter and the turbidimeter are checked for calibration daily while the plant is running. If they are found to be out of calibration they are calibrated. The chlorinators are rebuilt annually with maintenance kits. The levels of the equalization basin and Lakes 16 and 17 are monitored throughout the day for proper operation.

Effluent Exceeding Limitation Response

District personnel are made aware of a situation either by observing that the plant has shut down and then investigating the reason the plant shut down, by finding an instrument out of calibration or not operating correctly, or by alarms through notification by the south gate of a problem with the level of a lake or the equalization basin.

If tertiary effluent does not meet discharge requirements, an automated valve opens between the contact chamber and equalization basin to discharge the out of compliance water back into secondary holding Reservoir 1. If out of compliance water was to get into the equalization basin, the basin would be pumped back into secondary process pond #1. The Country Club Lakes that store the reclaimed water will be tested to see if the out of limit water has entered them.

If Lakes 16 and 17 are too high, above the high level probe at Pond 17, a high level float switch will activate and shut off the tertiary plant as well as shut the automated valve that feeds Pond 16 from the EQ basin. If there was an issue where Pond 17 was overflowing, or was in the process of filling too high, the discharge valve from the equalization basin will be shut manually and the proper authorities (see Emergency Phone Numbers list) will be notified.

If the equalization basin is overflowing or filling too high the reclamation facility will be shut down. The basin has not overflowed before and the flow should all go to Reservoir 1. If flow somehow made it to surface water the proper authorities will be notified.

As soon as time permits the notification part of the Effluent Exceeding Limitation Notification and Reporting section of this plan is started. If there is not time to start the Effluent Exceeding Limitation Response Evaluation during the event it will be filled out as soon as the problem has been stopped.

Copies of this plan are located at the wastewater reclamation facility, the Operation office, the Director of Field Operations Office, and the District's network drive.

Effluent Exceeding Limitation Notification and Reporting

As soon as an incident has been identified and we have time from dealing with it, the following entities are to be notified and the Effluent Exceeding Limitation Response Evaluation is to be filled out and filed with the appropriate office.

For an overflow that reaches surface water contact California Office of Emergency Services, California Regional Water Quality Control Board, and California Department of Fish and Game and file the response evaluation with California Office of Emergency Services.

For incidents where the water exceeds the discharge limits contact California Regional Water Quality Control Board and Rancho Murietta Country Club and file the response evaluation with California Regional Water Quality Control Board.

Emergency Phone Numbers

Outside Agencies

California Valley Regional Water Quality Control Board
Guy Childs
11020 Sun Center Drive #200
Rancho Cordova, CA 95827-3003
(916) 464-4648
Main Number (916)464-3291 Leave a voice mail for after hours.

California Office of Emergency Services
Inland Region
2800 Meadowview Road
Sacramento, CA 95832
(800) 852-7550 24-Hour Spill Notification Number

California Department of Fish and Wildlife
Dispatch
(916) 445-0045 24-Hour Spill Notification Number

Rancho Murieta Country Club
7000 Alameda Drive
Rancho Murieta, CA 95683
Arnie Billingsley, General Manager
(916) 354-3400
(916) 354-0916 FAX
Rich Scholes, Golf Course Superintendent
(916) 354-3490
(916)869-3560 Cell Phone

District Personnel

	Work
Ed Crouse General Manager	(916)354-3700 cell "on file" Home "on file"
Paul Siebensohn	(916)354-3700 cell "on file" Home "on file"
Rob McCleod	(916)354-3700 cell "on file" Home "on file"

Outside Contractors and Suppliers

Vince Carrillo	(916) 354-2581	Cell	(916) 716-8988
Pac Machine	(916) 387-1336		
4-Men Electric	(916) 933-0459		
Ace Hardware	(916) 354-1970		

Effluent Exceeding Limitation Response Evaluation

(Page 1 of 4)

Rancho Murieta Community Services District

Source of incident (check one): Chlorine Residual Coliform pH Turbidity
 Overflow

Incident Started: (Date/Time) _____ / _____

Incident Ended: (Date/Time) _____ / _____

Estimated Duration (Time) _____

First knowledge of incident: (Date/Time) _____ / _____

Estimated volume of incident of _____ gallons. Show rationale for volume.

Did incident reach surface waters? Yes No (If Yes, please list the following)

Volume reaching surface waters _____ gallons

Name of surface water _____

Did incident result in a fish kill? Yes No

If yes, what is the estimated number of fish killed? _____

If spill is ongoing, please notify Office of Emergency Services and Regional Water Quality Control Board on a daily basis until spill can be stopped.

The California Office of Emergency Services needs to be called only if there is an overflow of reclaimed water.

Reported to: California Office of Emergency Services (Date/time) _____

Name of person _____

Reported to: California Regional Water Quality Control Board (Date/time) _____

Name of person _____

Weather conditions: _____

Effluent Exceeding Limitation Response Evaluation

(Page 2 of 4)

Please provide the following information:

1. Location and type of incident: _____

2. Cause of incident: _____

3. Did you have personnel available to perform initial assessment 24 hours/day (including weekends and holidays)?

Yes _____ No _____

4. How long did it take to make an initial assessment of the incident after first knowledge?

_____ Hours _____ Minutes

How long did it take to get a repair crew onsite?

_____ Hours _____ Minutes

Please explain the time taken to make initial assessment: _____

Effluent Exceeding Limitation Response Evaluation

(Page 3 of 4)

5. Action taken to contain the incident and/or remediation of the site: _____

6. Were the equipment and parts needed to make repairs readily available?

Yes _____ No _____ If no, please explain why: _____

7. Did the monitoring equipment function at the time of the incident? Yes _____ No _____ if not, please explain why: _____

Effluent Exceeding Limitation Response Evaluation

(Page 4 of 4)

8. Repairs made are: Permanent _____ Temporary _____

Please describe what repairs were made. If the repairs are temporary, please indicate a date by which permanent repairs will be completed, and notify the Regional Office within 7 days of the permanent repair: _____

9. What actions have been made to prevent this discharge from occurring again in the future?

10. Comments: _____

Other agencies notified: _____

Person reporting incident: _____ Phone Number: _____

Signature _____ Date: _____

Post Effluent Exceeding Limitation Assessment

Soon after the problem has been corrected, any repairs have been made, and all notifications and reports submitted, the staff that was involved with the incident, and management will meet to assess the cause of the incident and their response to it.

Using the filled out Effluent Exceeding Limitation Response Evaluation the cause of the incident will be looked at to see if there is something that we could implement or install to reduce the chances of that type of incident occurring again. The time it took to respond, our response to the incident, and any corrective action we took will be looked at to see if there is anything that we can improve on for the next time. Also we will check to see if there were any trends that were monitored that indicated a problem. We will also see if there is any equipment that we do not own which could have aided in our correcting the situation. If the problem was caused by mechanical failure then the alarm system and equipment reliability will be looked at to see if there is anything that can be modified to alleviate the situation.

Appendix F – Golf Course Irrigation Drawings

PLANS FOR IMPROVEMENTS OF RANCHO MURIETA WASTEWATER RECLAMATION NORTH GOLF COURSE IRRIGATION SYSTEMS SACRAMENTO COUNTY, CALIFORNIA.

IRRIGATION SYSTEM DEMAND

CONTROLLER	8 PM	9 PM	10 PM	11 PM	12 MN	1 AM	2 AM	3 AM	4 AM	5 AM	6 AM	
FAIRWAY 1&2	130	132	138	132	132	132	110	175	181			
3	88	132	163	175	154	132	138	138	97	110		
4								88	175	132	132	
5	110	132	132	132	132	154	66	132	110			
6	110	132	88	66	132	110	132	176	88	88		
7												
8	110	132	110	154	154	110	110	176	132	154	132	
9									110	110	88	
10	40	88	88	132	132	132	176	176	176	132	110	
11	132	154	142	132	132	110	110	176	132	132	110	
12												
13	110	110	110	132	110	176	132	132	110	110	110	
14										164	132	
15	120	132	132	132	154	154	174	132	132	132	110	
16										110	176	
17												
FAIRWAY 18									176	88	132	
GREENS 1-4	66	GREENS 1-4				66	66	LODGE				66
5-9	66	GREENS 5-9				66	66	LODGE				66
10-14	66	GREENS 10-14				66	66	CLUBHOUSE				66
GREENS 15-18	66	GREENS 15-18				66	66	CLUBHOUSE				66
DRIVING RANGE										132	154	
PARK	540	COMMUNITY PARK				540	540	540	540	540	540	
TOTAL FLOW	220	1798	1904	1885	2057	2014	2036	2012	2086	1932	2044	
		1887	1662	1884	1816	1838	2124	2002	2058	1936	1866	

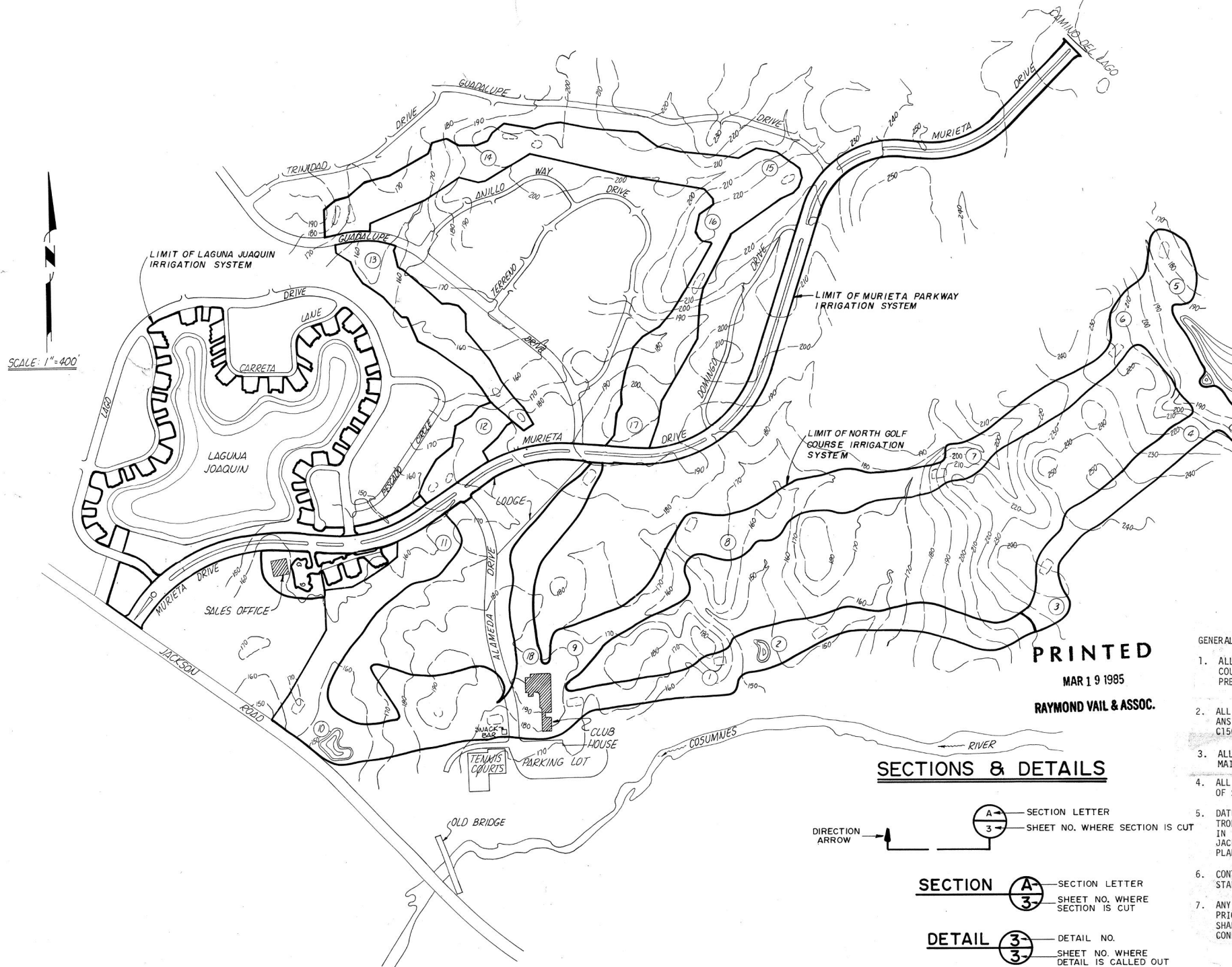

INDEX OF DRAWINGS

SHEET N ^o	TITLE
1.	TITLE SHEET
2.	IRRIGATION PLAN
3.	PIPING CONNECTION AT FAIRWAY 10
4.	PIPING CONNECTION AT BASS LAKE
5.	DETAILS

GENERAL NOTES

1. ALL PROPOSED WATER AND IRRIGATION MAIN PIPING, FITTINGS, VALVES, FLANGE COUPLING ADAPTORS AND SPECIALTIES SHALL BE RATED FOR 150 PSI WORKING PRESSURE. 30" MINIMUM COVER REQUIRED AT ALL TIMES.
2. ALL PROPOSED PIPE AND FITTINGS SHALL BE DUCTILE IRON, CONFORMING TO ANSI SPECIFICATIONS A21.50, A21.51, A21.4, A21.11, A21.10 AND ANWA C150-76.
3. ALL BACKFLOW PREVENTER PITS SHALL BE PROVIDED WITH PADLOCKS KEYPED TO MAINTENANCE PERSONNEL KEYS.
4. ALL CONSTRUCTION AND MATERIALS SHALL BE IN ACCORDANCE WITH THE COUNTY OF SACRAMENTO BUILDING DEPARTMENT REQUIREMENTS.
5. DATUM: THE VERTICAL DATUM FOR THIS PROJECT WAS ESTABLISHED FROM CONTROL POINT R-507 ELEVATION 198.07 SET BY GEORGE S. NOLTE & ASSOCIATES IN 1969. LOCATED SOUTH 4780' AND EAST 3610' FROM THE INTERSECTION OF JACKSON HIGHWAY AND MURIETA PARKWAY, UNLESS OTHERWISE SHOWN ON THE PLANS.
6. CONTRACTOR SHALL NOTIFY OWNER'S REPRESENTATIVE 48 HOURS PRIOR TO STARTING OR RESTARTING CONSTRUCTION.
7. ANY EXISTING UTILITY TO BE EXTENDED SHALL BE EXPOSED BY THE CONTRACTOR PRIOR TO THE STAKING OF SUCH UTILITIES. THE ENGINEER SHALL THEN VERIFY THE EXISTING LOCATION AND/OR ELEVATION FOR POSSIBLE CONFLICTS WITH PLANS.

8. ALL WATER AND SEWER SYSTEM CONSTRUCTION SHALL CONFORM TO EL DORADO IRRIGATION DISTRICT (E.I.D.) SPECIFICATIONS AND DRAWINGS AS APPLICABLE.
9. EXISTING FACILITIES INCLUDING BUT NOT RESTRICTED TO CULVERTS, PIPING, VALVES, AND FITTINGS WHICH ARE REMOVED BUT NOT REUSED SHALL BE SALVAGED AND RELOCATED TO AN AREA ON RANCHO MURIETA PROPERTIES AS INDICATED BY THE ENGINEER. EXISTING WATER AND SEWER FACILITIES ARE THE PROPERTY OF E.I.D.
10. THE CONTRACTOR SHALL EXPOSE EXISTING UTILITIES AT CROSSINGS OF EXISTING AND PROPOSED UTILITIES PRIOR TO THE STAKING OF THE PROPOSED UTILITIES BY THE ENGINEER. THE ENGINEER SHALL VERIFY THAT NO GRADE CONFLICTS OCCUR. IF IN THE OPINION OF THE ENGINEER A GRADE CONFLICT DOES OCCUR, THE ENGINEER SHALL MAKE ANY GRADE ADJUSTMENT NECESSARY TO RESOLVE THE GRADE CONFLICT. NO ADJUSTMENT IN BID PRICES WILL BE ALLOWED AS A RESULT OF SUCH GRADE ADJUSTMENTS.
11. THE TYPES, LOCATIONS, SIZES, AND DEPTHS OF EXISTING UNDERGROUND UTILITIES AS SHOWN ON THESE IMPROVEMENT PLANS WERE OBTAINED FROM SOURCES OF VARYING RELIABILITY. A REASONABLE EFFORT HAS BEEN MADE TO LOCATE AND DELINEATE ALL KNOWN UNDERGROUND UTILITIES. HOWEVER, THE ENGINEER CAN ASSUME NO RESPONSIBILITY FOR THE COMPLETENESS OR ACCURACY OF ITS DELINEATION OF SUCH UNDERGROUND UTILITIES NOR FOR THE EXISTENCE OF OTHER BURIED OBJECTS OR UTILITIES WHICH MAY BE ENCOUNTERED BUT WHICH ARE NOT SHOWN ON THESE DRAWINGS. THE CONTRACTOR SHALL BE RESPONSIBLE FOR DETERMINING THE EXACT LOCATIONS OF THOSE UTILITIES SHOWN AND ANY WHICH MAY EXIST AND ARE NOT SHOWN PRIOR TO COMMENCEMENT OF ANY WORK. THE CONTRACTOR SHALL EXPOSE ALL UNDERGROUND FACILITIES THAT ARE TO BE CONNECTED TO OR THAT ARE IN THE PATH OF THE PROPOSED IMPROVEMENTS FOR VERIFICATIONS OF LOCATION AND ELEVATION PRIOR TO COMMENCING CONSTRUCTION.
12. THE CONTRACTOR IS ADVISED THAT CONFORMANCE TO MINIMUM COVER REQUIREMENTS PER PLANS AND SPECIFICATIONS OVER UNDERGROUND PIPING SHALL BE STRICTLY ENFORCED. DESIGN GRADES FOR PIPING INSTALLATION SHALL BE STRICTLY ENFORCED.
13. FOR LOCATION OF UTILITIES, CALL U.S.A. (800) 642-2444 2 DAYS PRIOR TO CONSTRUCTION.
14. ONLY LIGHT WEIGHT CONSTRUCTION EQUIPMENT SHALL BE ALLOWED IN TURFED AND FAIRWAY AREAS. THE OWNER WILL REMOVE AND REPLACE THE TURF IN THE IMMEDIATE VICINITY OF THE WORK TO PROVIDE THE CONTRACTOR WITH REASONABLE WORKING SPACE.
15. FIRE PROTECTION TO CLUBHOUSE SHALL NOT BE INTERRUPTED FOR MORE THAN 6 HOURS. COORDINATE WITH LOCAL FIRE DEPARTMENT.

NOTES CONTINUED ON SHEET 2

SECTIONS & DETAILS

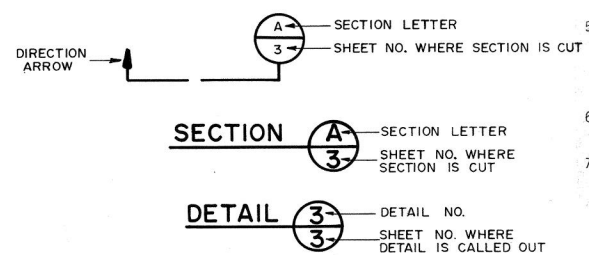

PRINTED
MAR 19 1985
RAYMOND VAIL & ASSOC.

DRAWN BY: MDH.	DESIGN BY: EAL	REVISION	DATE	DESCRIPTION
CHECK BY: KCG				3/25/85 FINAL "AS-BUILT" WORK DONE IN 1983
BY:				

RAYMOND VAIL AND ASSOCIATES
ENGINEERING • PLANNING • SURVEYING
SACRAMENTO, CALIFORNIA 1410 Ethan Way 95825

PROPOSED IMPROVEMENTS FOR
NORTH GOLF COURSE IRRIGATION SYSTEMS
TITLE SHEET

DATE: FEB 1983
SCALE: 1" = 400'
HORIZONTAL
VERTICAL
W.O. NO. 1205.18Y

SHEET
1 OF **5**
SHEETS

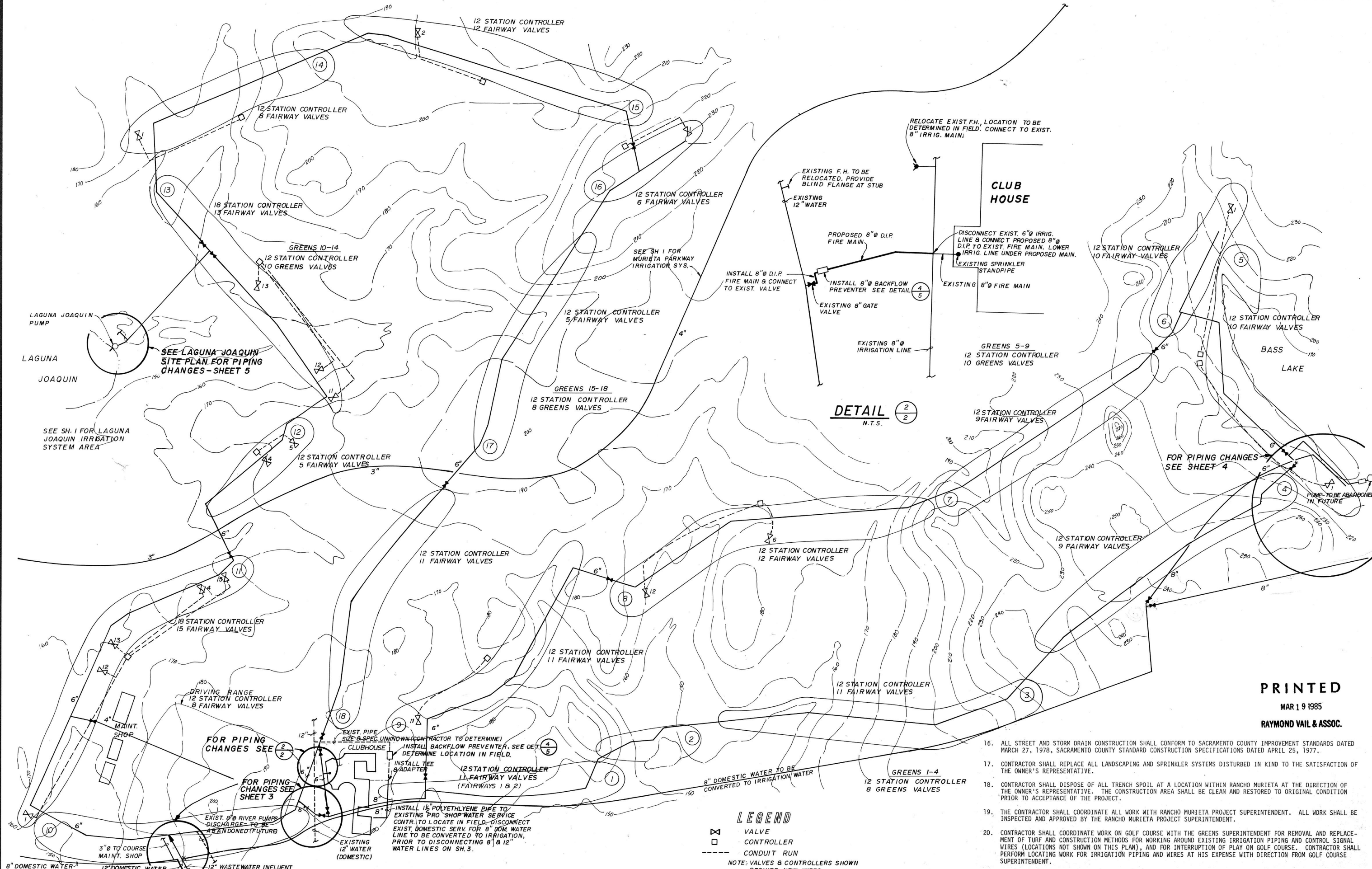

DETAIL 2/2
N.T.S.

LEGEND
 X VALVE
 □ CONTROLLER
 --- CONDUIT RUN
 NOTE: VALVES & CONTROLLERS SHOWN REQUIRE NEW WIRES

CLUB HOUSE

PRINTED
 MAR 19 1985
 RAYMOND VAIL & ASSOC.

16. ALL STREET AND STORM DRAIN CONSTRUCTION SHALL CONFORM TO SACRAMENTO COUNTY IMPROVEMENT STANDARDS DATED MARCH 27, 1978, SACRAMENTO COUNTY STANDARD CONSTRUCTION SPECIFICATIONS DATED APRIL 25, 1977.
17. CONTRACTOR SHALL REPLACE ALL LANDSCAPING AND SPRINKLER SYSTEMS DISTURBED IN KIND TO THE SATISFACTION OF THE OWNER'S REPRESENTATIVE.
18. CONTRACTOR SHALL DISPOSE OF ALL TRENCH SPOIL AT A LOCATION WITHIN RANCHO MURIETA AT THE DIRECTION OF THE OWNER'S REPRESENTATIVE. THE CONSTRUCTION AREA SHALL BE CLEAN AND RESTORED TO ORIGINAL CONDITION PRIOR TO ACCEPTANCE OF THE PROJECT.
19. THE CONTRACTOR SHALL COORDINATE ALL WORK WITH RANCHO MURIETA PROJECT SUPERINTENDENT. ALL WORK SHALL BE INSPECTED AND APPROVED BY THE RANCHO MURIETA PROJECT SUPERINTENDENT.
20. CONTRACTOR SHALL COORDINATE WORK ON GOLF COURSE WITH THE GREENS SUPERINTENDENT FOR REMOVAL AND REPLACEMENT OF TURF AND CONSTRUCTION METHODS FOR WORKING AROUND EXISTING IRRIGATION PIPING AND CONTROL SIGNAL WIRES (LOCATIONS NOT SHOWN ON THIS PLAN), AND FOR INTERRUPTION OF PLAY ON GOLF COURSE. CONTRACTOR SHALL PERFORM LOCATING WORK FOR IRRIGATION PIPING AND WIRES AT HIS EXPENSE WITH DIRECTION FROM GOLF COURSE SUPERINTENDENT.

DRAWN BY: RAW DESIGN BY: EAL
 CHECK BY: KCG
 BY:

REVISION	DATE	DESCRIPTION

RVA RAYMOND VAIL AND ASSOCIATES
 ENGINEERING • PLANNING • SURVEYING
 SACRAMENTO, CALIFORNIA 1410 Ethan Way 95825

PROPOSED IMPROVEMENTS FOR
 NORTH GOLF COURSE IRRIGATION SYSTEMS
 IRRIGATION PLAN

DATE FEB 83 SHEET
 SCALE: 2 OF 5
 HORIZONTAL 1"=200'
 VERTICAL
 W/O NO. 1205.18V SHEETS

RANCHO MURIETA

CALIFORNIA

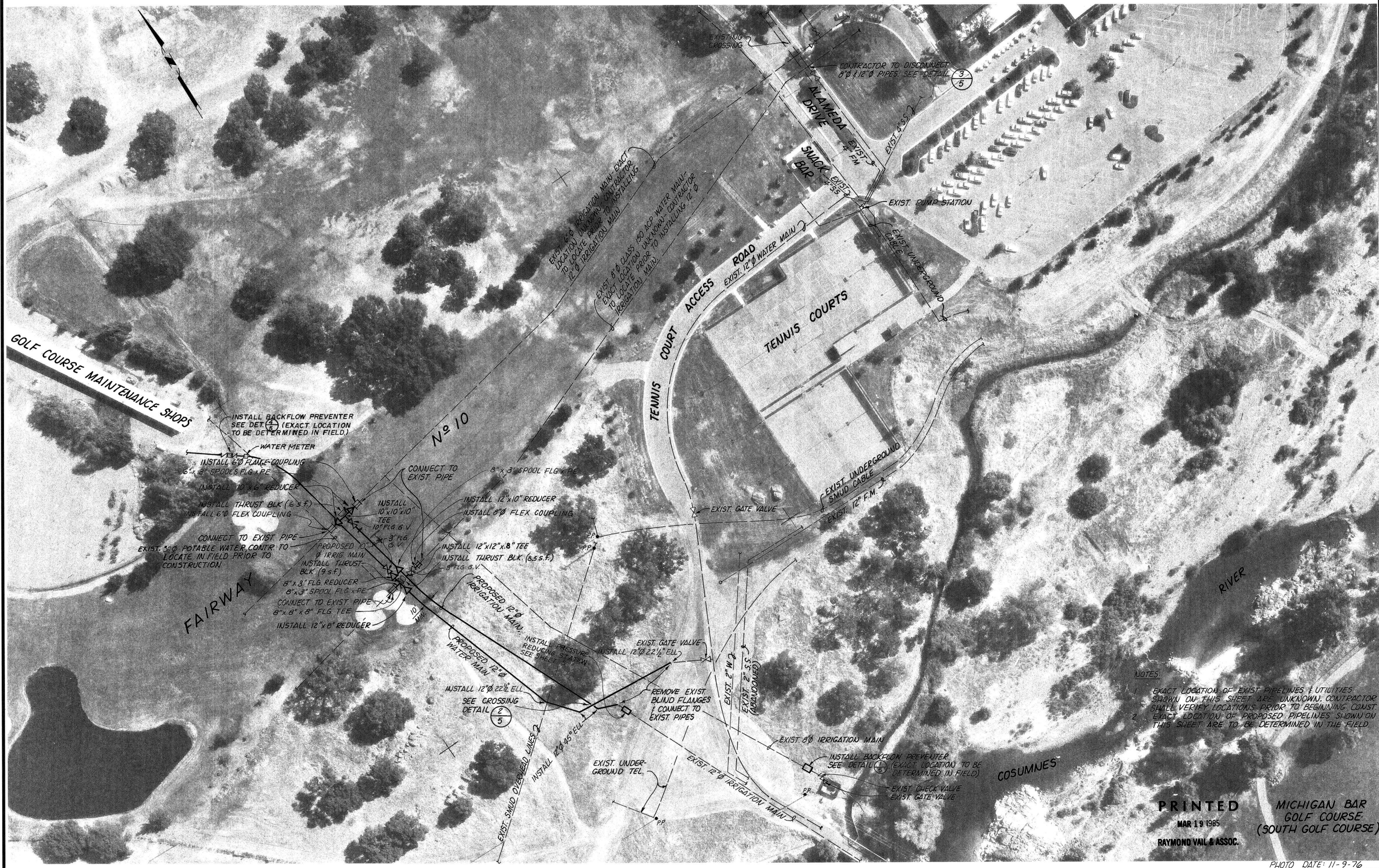

NOTES:
 1. EXACT LOCATION OF EXIST PIPELINES & UTILITIES SHOWN ON THIS SHEET ARE UNKNOWN. CONTRACTOR SHALL VERIFY LOCATIONS PRIOR TO BEGINNING CONST.
 2. EXACT LOCATION OF PROPOSED PIPELINES SHOWN ON THIS SHEET ARE TO BE DETERMINED IN THE FIELD.

PRINTED
 MAR 19 1985
 RAYMOND VAIL & ASSOC.
 MICHIGAN BAR GOLF COURSE (SOUTH GOLF COURSE)

PHOTO DATE: 11-9-76

DRAWN BY: MDH DESIGN BY: EAL
 CHECK BY: KCG
 BY:

REVISION	DATE	DESCRIPTION
7	4-13-83	REALIGN 12" IRRIGATION AND 12" WATER MAINS
	2-85	VALVE ASSEMBLYS ETC UPDATED AS BUILT

RVA RAYMOND VAIL AND ASSOCIATES
 ENGINEERING • PLANNING • SURVEYING
 SACRAMENTO, CALIFORNIA 1410 Ethan Way 95825

PROPOSED IMPROVEMENTS FOR
 NORTH GOLF COURSE IRRIGATION SYSTEMS
PIPING CONNECTION AT FAIRWAY 10
 RANCHO MURIETA CALIFORNIA

DATE FEB, 1983 SHEET
 SCALE 1"=50'
 HORIZONTAL
 VERTICAL
 W.O. NO. 1205.18 V SHEETS

3 OF 5



BASS LAKE

- NOTES
1. EXACT LOCATION OF EXIST. PIPELINES & UTILITIES SHOWN ON THIS SHEET ARE UNKNOWN. CONTRACTOR SHALL VERIFY LOCATIONS PRIOR TO BEGINNING CONST.
 2. EXACT LOCATION OF PROPOSED PIPELINES SHOWN ON THIS SHEET ARE TO BE DETERMINED IN THE FIELD.

PRINTED
MAR 19 1985
RAYMOND VAIL & ASSOC.

PHOTO DATE: 11-9-76

DRAWN BY: MDH DESIGN BY: EAL
CHECK BY: KCG
BY:

REVISION	DATE	DESCRIPTION
	4-11-83	AS-BUILT INFORMATION
	2-85	VALVE ASSEMBLYS ETC. UPDATED - AS BUILT

RVA RAYMOND VAIL AND ASSOCIATES
ENGINEERING • PLANNING • SURVEYING
SACRAMENTO, CALIFORNIA 1410 Ethan Way 95825

PROPOSED IMPROVEMENTS FOR
NORTH GOLF COURSE IRRIGATION SYSTEMS
PIPING CONNECTION AT BASS LAKE

DATE FEB. 1983 SHEET
SCALE: 1" = 50'
HORIZONTAL
VERTICAL
W.O. NO. 1205.18V SHEETS

4 OF 5

RANCHO MURIETA CALIFORNIA

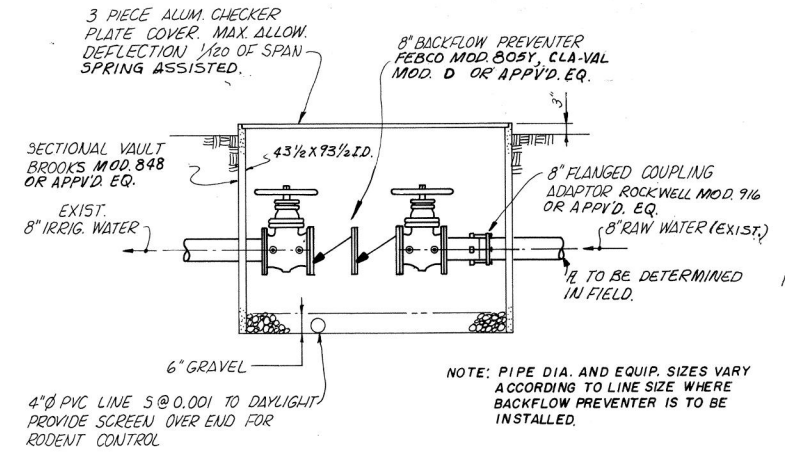

BACKFLOW PREVENTER DETAIL 1
NO SCALE

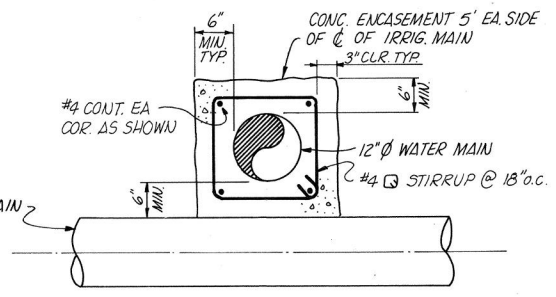

CROSSING DETAIL 2
NO SCALE

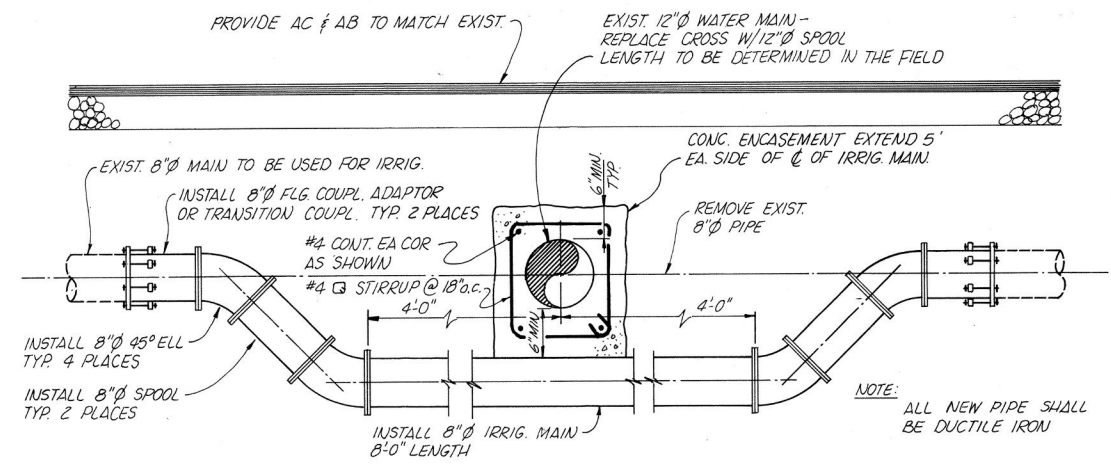

CROSSING DETAIL 3
NO SCALE

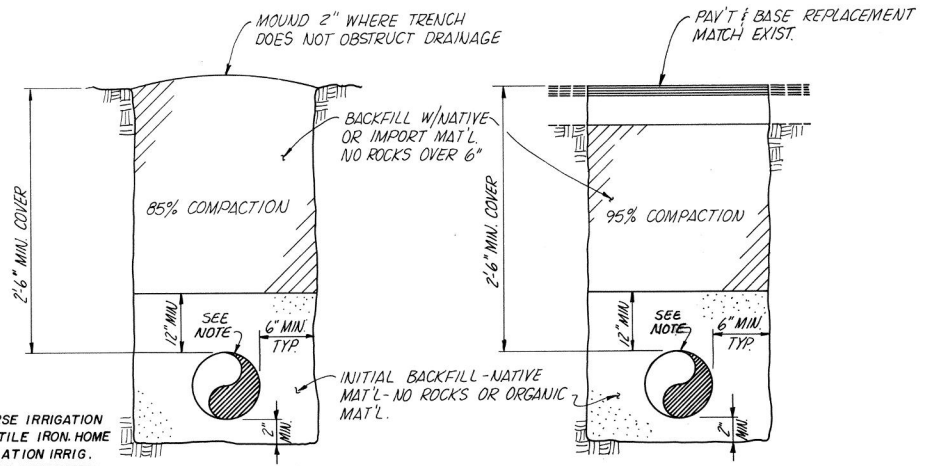

TRENCH DETAILS
NO SCALE

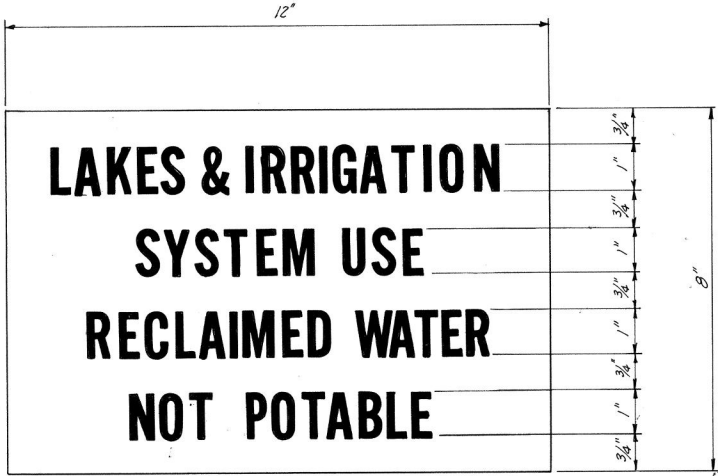

SPECIFICATIONS:
 SIZE.....8"x12"
 COLOR.....#12 RED BACKGROUND W/WHITE COPY.
 FINISH.....FUSED PORCELAIN CERAMIC.
 MOUNTING.....FOUR GROMMETED HOLES FOR #10 FASTENER.
 END USE.....EXTERIOR.
 STEEL.....18 GAGE VITREOUS ENAMELING STOCK.
 MFR.....FERRO ENAMELING CO. OR EQ.
 NOTE: MADE IN ACCORDANCE WITH PORCELAIN ENAMEL INSTITUTE SIGN SPEC. PEI: S-103 CURRENT EDITION.

SIGN DETAIL
1/2" = 1'-0"

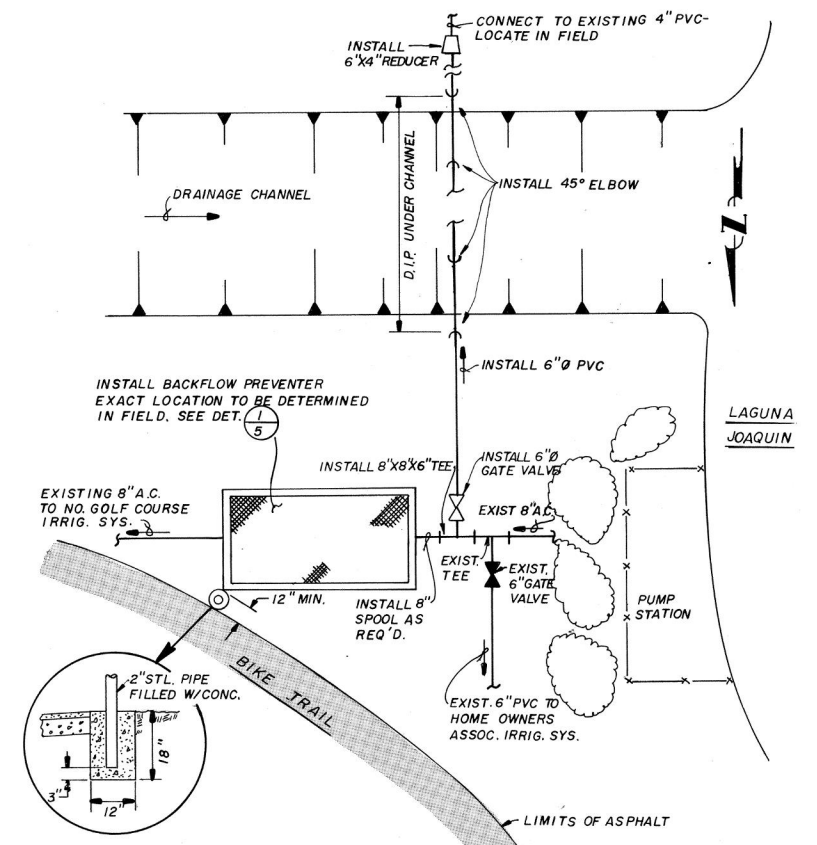

LAGUNA JOAQUIN SITE PLAN
1/4" = 1'-0"

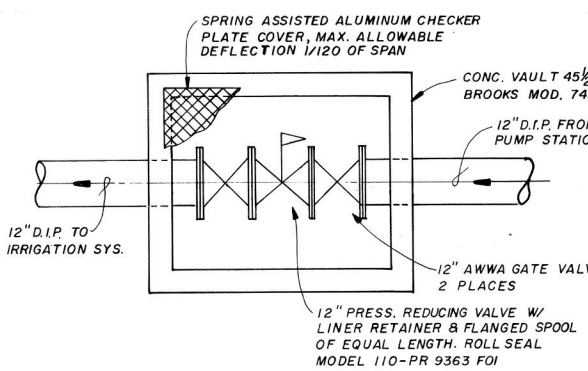

PRESSURE REDUCING STATION
1/2" = 1'-0"

DIAMETER OF PIPE	22 1/2°			45°			90°			TEE & DEAD ENDS		
	HORIZONTAL SURFACE AREA	VERTICAL SURFACE AREA	WEIGHT	HORIZONTAL SURFACE AREA	VERTICAL SURFACE AREA	WEIGHT	HORIZONTAL SURFACE AREA	VERTICAL SURFACE AREA	WEIGHT	HORIZONTAL SURFACE AREA	VERTICAL SURFACE AREA	WEIGHT
IN.	SQ. FT.	SQ. FT.	IN. LBS.	SQ. FT.	SQ. FT.	IN. LBS.	SQ. FT.	SQ. FT.	IN. LBS.	SQ. FT.	SQ. FT.	IN. LBS.
4	1	1	1,000	1	1	1,000	2	2	2,000	2	2	2,000
6	1	1	1,700	2	2	3,400	3	3	5,100	3	3	5,100
8	1.5	1.5	2,400	3	3	4,800	5	5	10,000	5	5	10,000
10	2	2	3,400	4	4	6,800	8	8	17,000	8	8	17,000
12	3	3	5,100	6	6	10,200	12	12	24,000	12	12	24,000
14	4.5	4.5	9,000	9	9	18,000	18	18	41,700	18	18	41,700
16	6	6	11,800	12	12	23,600	24	24	52,300	24	24	52,300
18	7.5	7.5	14,800	15	15	29,600	27	27	66,800	27	27	66,800

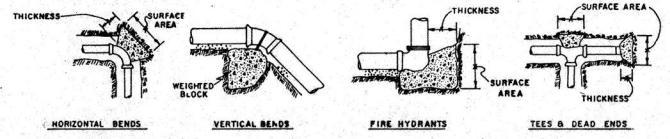

NOTE: ALL VALUES SHOWN ARE MINIMUM FOR A HYDROSTATIC PRESSURE OF 150 PSI AND A SOIL RESISTANCE OF 2,000 LBS./SQ. FT. WITH PIPELINE & MINIMUM OF 2 FEET OF COVER.
 2. GRAVITY LINES, ALL SIZES, 10 PSI OR LESS, USE THE 4" DIMENSION ABOVE.

THRUST BLOCK DIMENSIONS

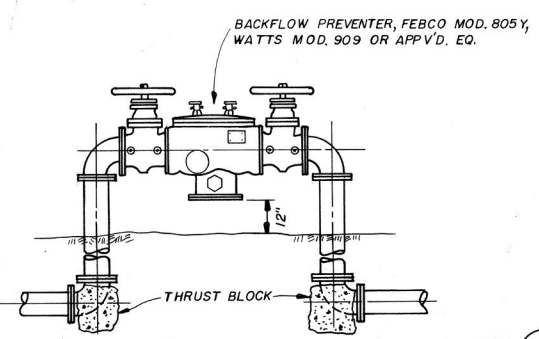

ABOVE GROUND BACKFLOW PREVENTER
N.T.S.

DRAWN BY: MDH DESIGN BY: EAL
 CHECK BY: KCG
 BY:

REVISION	DATE	DESCRIPTION

RVA RAYMOND VAIL AND ASSOCIATES
 ENGINEERING • PLANNING • SURVEYING
 SACRAMENTO, CALIFORNIA 1410 Ethan Way 95825

PROPOSED IMPROVEMENTS FOR
NORTH GOLF COURSE IRRIGATION SYSTEMS
DETAILS
 RANCHO MURIETA CALIFORNIA

DATE: FEB. 1983 SHEET: 5 OF 5
 SCALE: AS NOTED
 HORIZONTAL: AS NOTED
 VERTICAL: AS NOTED
 W.O. NO. 1205.IBV SHEETS

PRINTED
 MAR 19 1985
 RAYMOND VAIL & ASSOC.

PLANS FOR IMPROVEMENTS
OF
RANCHO MURIETA WASTEWATER RECLAMATION
SOUTH GOLF COURSE IRRIGATION SYSTEMS
SACRAMENTO COUNTY, CALIFORNIA.

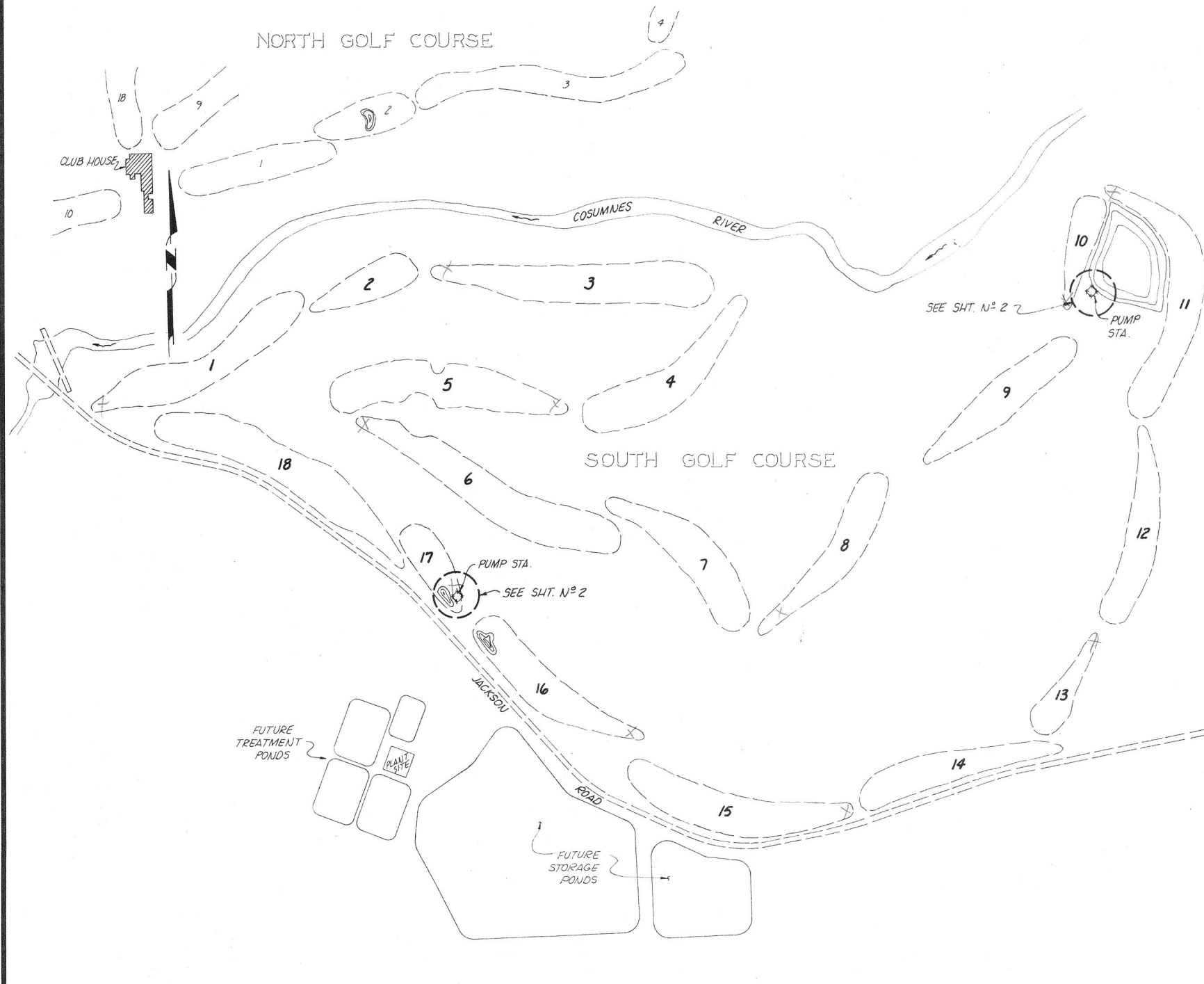

GENERAL NOTES

1. ALL PROPOSED IRRIGATION MAIN PIPING, FITTINGS, VALVES AND SPECIALTIES SHALL BE RATED FOR 150 PSI WORKING PRESSURE - 30 INCHES MINIMUM COVER REQUIRED AT ALL TIMES.
2. ALL PROPOSED PIPE AND FITTINGS SHALL BE DUCTILE IRON, CONFORMING TO ANSI SPECIFICATIONS A21.50, A21.51, A21.4, A21.11, A21.10 AND AWWA C150-76.
3. CORNELL PUMP AND VERTICAL MOTOR SHOWN IN SCHEMATIC ③ SHALL BE SALVAGED FROM STORAGE AT THE EXISTING WASTEWATER TREATMENT PLANT YARD. THE MOTOR SHALL BE SENT TO AN AUTHORIZED MOTOR REPAIR DEALER FOR A BASIC REPAIR CONSISTING OF THE FOLLOWING:
 - A) TEST RUN MOTOR TO CHECK FOR VIBRATIONS
 - B) CHECK BEARING FITS
 - C) REPLACE BEARINGS
 - D) STEAM CLEAN
 - E) BAKE UNTIL DRY
 - F) DIP IN VARNISH - ONE COAT
 - G) BAKE AGAIN UNTIL DRY
 - H) TEST OPERATE
 - I) REPAINT MOTOR

IN ADDITION, THE PUMP SHALL BE PROVIDED WITH NEW BEARINGS AND MECHANICAL SEAL. THE PLANT MANAGER SHALL DETERMINE WHICH PUMP AND MOTOR IS TO BE SALVAGED. NOTIFY ENGINEER IF DURING BASIC REPAIR ANY OTHER REPAIR WORK IS REQUIRED.

4. ALL CONSTRUCTION AND MATERIALS SHALL BE IN ACCORDANCE WITH THE COUNTY OF SACRAMENTO BUILDING DEPARTMENT REQUIREMENTS.
5. DATUM: THE VERTICAL DATUM FOR THIS PROJECT WAS ESTABLISHED FROM CONTROL POINT R-507 ELEVATION 198.07 SET BY GEORGE S. NOLTE & ASSOCIATES IN 1969. LOCATED SOUTH 4780' AND EAST 3610' FROM THE INTERSECTION OF JACKSON HIGHWAY AND MURIETA PARKWAY, UNLESS OTHERWISE SHOWN ON THE PLANS.

6. CONTRACTOR SHALL NOTIFY OWNER'S REPRESENTATIVE 48 HOURS PRIOR TO STARTING OR RESTARTING CONSTRUCTION.
7. EXISTING FACILITIES INCLUDING BUT NOT RESTRICTED TO CULVERTS, PIPING, VALVES, AND FITTINGS WHICH ARE REMOVED BUT NOT REUSED SHALL BE SALVAGED AND RELOCATED TO AN AREA ON RANCHO MURIETA PROPERTIES AS INDICATED BY THE ENGINEER.

8. THE TYPES, LOCATIONS, SIZES, AND DEPTHS OF EXISTING UNDERGROUND UTILITIES AS SHOWN ON THESE IMPROVEMENT PLANS WERE OBTAINED FROM SOURCES OF VARYING RELIABILITY. A REASONABLE EFFORT HAS BEEN MADE TO LOCATE AND DELINEATE ALL KNOWN UNDERGROUND UTILITIES. HOWEVER, THE ENGINEER CAN ASSUME NO RESPONSIBILITY FOR THE COMPLETENESS OR ACCURACY OF ITS DELINEATION OF SUCH UNDERGROUND UTILITIES NOR FOR THE EXISTENCE OF OTHER BURIED OBJECTS OR UTILITIES WHICH MAY BE ENCOUNTERED BUT WHICH ARE NOT SHOWN ON THESE DRAWINGS. THE CONTRACTOR SHALL BE RESPONSIBLE FOR DETERMINING THE EXACT LOCATIONS OF THOSE UTILITIES SHOWN AND ANY WHICH MAY EXIST AND ARE NOT SHOWN PRIOR TO COMMENCEMENT OF ANY WORK. THE CONTRACTOR SHALL EXPOSE ALL UNDERGROUND FACILITIES THAT ARE TO BE CONNECTED TO OR THAT ARE IN THE PATH OF THE PROPOSED IMPROVEMENTS FOR VERIFICATIONS OF LOCATION AND ELEVATION PRIOR TO COMMENCING CONSTRUCTION.

9. FOR LOCATION OF UTILITIES, CALL U.S.A. (800) 642-2444 2 DAYS PRIOR TO CONSTRUCTION.

10. ALL STREET AND STORM DRAIN CONSTRUCTION SHALL CONFORM TO SACRAMENTO COUNTY IMPROVEMENT STANDARDS DATED MARCH 27, 1978, SACRAMENTO COUNTY STANDARD CONSTRUCTION SPECIFICATIONS DATED APRIL 25, 1977.

11. CONTRACTOR SHALL REPLACE ALL LANDSCAPING AND SPRINKLER SYSTEMS DISTURBED IN KIND TO THE SATISFACTION OF THE OWNER'S REPRESENTATIVE.

12. CONTRACTOR SHALL DISPOSE OF ALL TRENCH SPOIL AT A LOCATION WITHIN RANCHO MURIETA AT THE DIRECTION OF THE OWNER'S REPRESENTATIVE. THE CONSTRUCTION AREA SHALL BE CLEAN AND RESTORED TO ORIGINAL CONDITION PRIOR TO ACCEPTANCE OF THE PROJECT.

13. THE CONTRACTOR SHALL COORDINATE ALL WORK WITH RANCHO MURIETA PROJECT SUPERINTENDENT. ALL WORK SHALL BE INSPECTED AND APPROVED BY THE RANCHO MURIETA PROJECT SUPERINTENDENT.

14. CONTRACTOR SHALL COORDINATE WORK ON GOLF COURSE WITH THE GREENS SUPERINTENDENT FOR REMOVAL AND REPLACEMENT OF TURF AND CONSTRUCTION METHODS FOR WORKING AROUND EXISTING IRRIGATION PIPING AND CONTROL SIGNAL WIRES (LOCATIONS NOT SHOWN ON THIS PLAN), AND FOR INTERRUPTION OF PLAY ON GOLF COURSE. CONTRACTOR SHALL PERFORM LOCATING WORK FOR IRRIGATION PIPING AND WIRES AT HIS EXPENSE WITH DIRECTION FROM GOLF COURSE SUPERINTENDENT.

INDEX OF DRAWINGS

SHEET N°	TITLE
1.	TITLE SHEET
2.	PUMP STATIONS AT FAIRWAYS 10 & 17
3.	DETAILS

SECTIONS & DETAILS

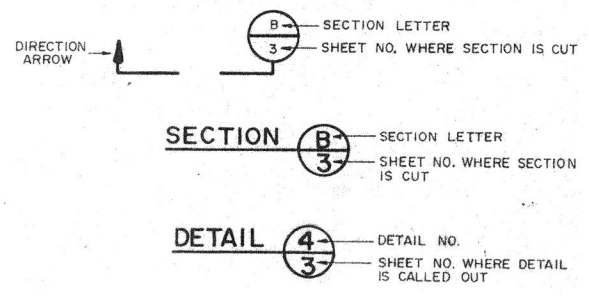

DRAWN BY: MDH DESIGN BY: EAL
CHECK BY: KCG
BY: _____

REVISION	DATE	DESCRIPTION

RVA RAYMOND VAIL AND ASSOCIATES
ENGINEERING • PLANNING • SURVEYING
SACRAMENTO, CALIFORNIA 1410 Ethan Way 95825

PROPOSED IMPROVEMENTS FOR
SOUTH GOLF COURSE IRRIGATION SYSTEMS
TITLE SHEET

RANCHO MURIETA CALIFORNIA

DATE: FEB 1983
SCALE: HORIZONTAL 1" = 400'
VERTICAL _____
W.O. NO. 1205.11T

SHEET
1 OF **3**
SHEETS

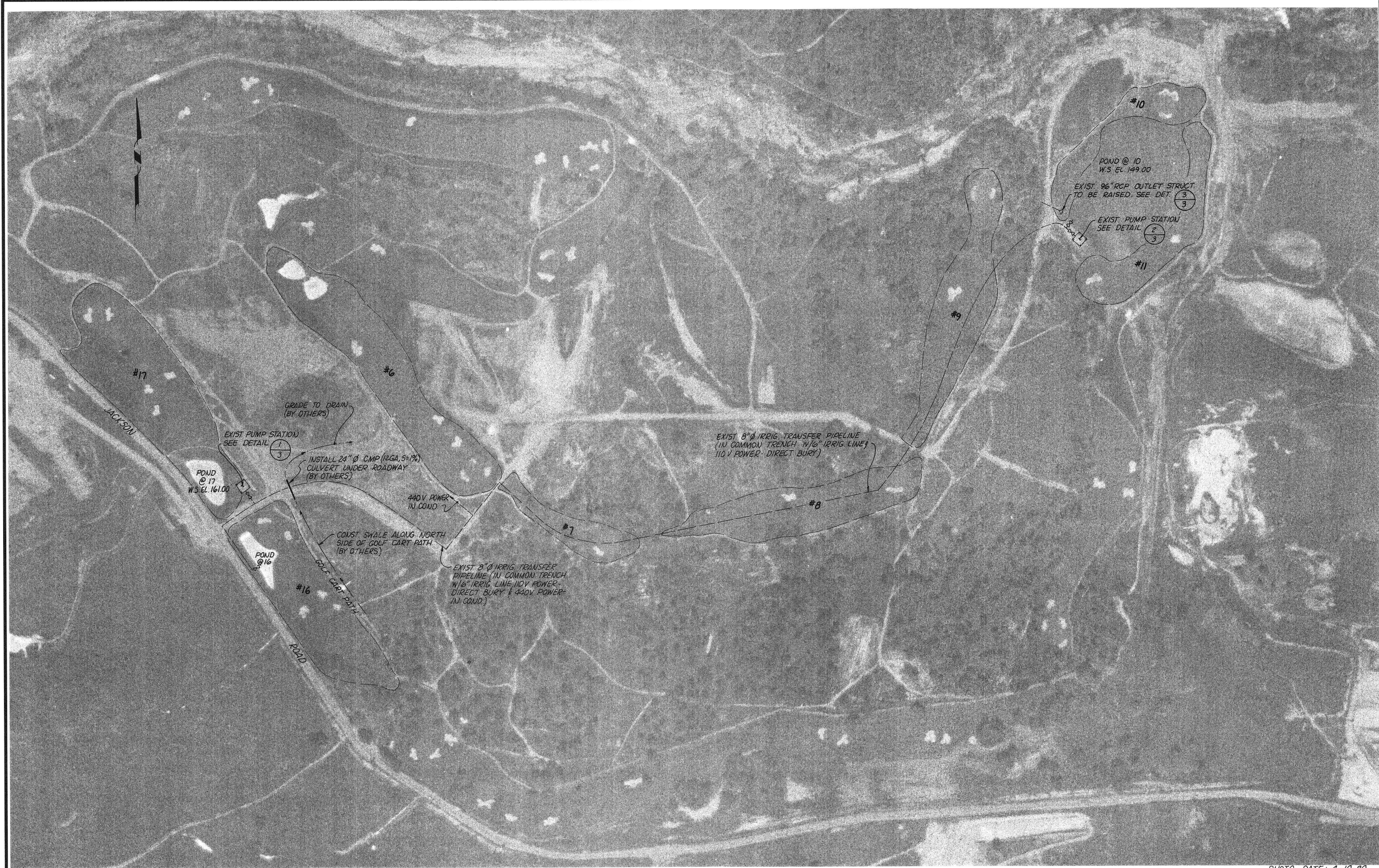

PHOTO DATE: 4-10-80

DRAWN BY: M D H DESIGN BY: E A L
 CHECK BY: K C G
 BY: _____

REVISION	DATE	DESCRIPTION

RVA RAYMOND VAIL AND ASSOCIATES
 ENGINEERING • PLANNING • SURVEYING
 SACRAMENTO, CALIFORNIA 1410 Ethan Way 95825

PROPOSED IMPROVEMENTS FOR
 SOUTH GOLF COURSE IRRIGATION SYSTEMS
PUMP STATIONS AT FAIRWAYS 10 & 17
 RANCHO MURIETA CALIFORNIA

DATE: FEB 1983 SHEET
 SCALE: 1" = 200'
 HORIZONTAL: _____
 VERTICAL: _____
 W.O. NO. 1205.11T SHEETS
2 OF **3**

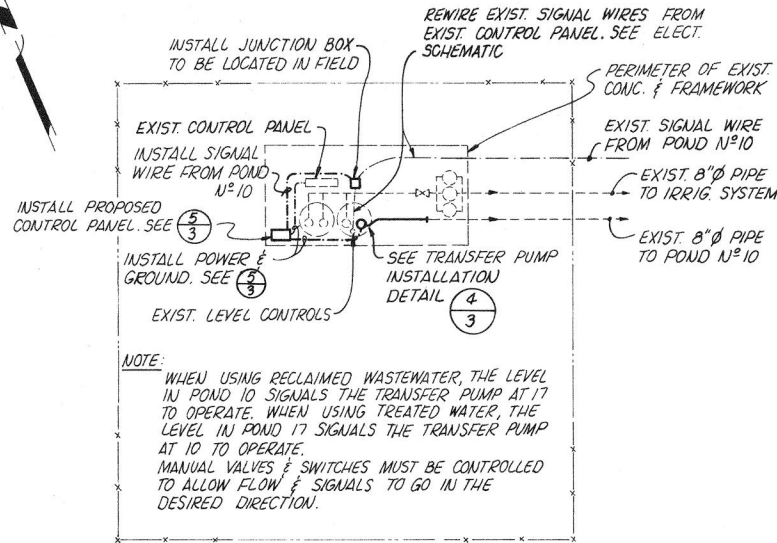

NOTE:
WHEN USING RECLAIMED WASTEWATER, THE LEVEL IN POND 10 SIGNALS THE TRANSFER PUMP AT 17 TO OPERATE. WHEN USING TREATED WATER, THE LEVEL IN POND 17 SIGNALS THE TRANSFER PUMP AT 10 TO OPERATE.
MANUAL VALVES & SWITCHES MUST BE CONTROLLED TO ALLOW FLOW & SIGNALS TO GO IN THE DESIRED DIRECTION.

PUMP STATION SCHEMATIC @ POND 17
SCALE: 1"=10'

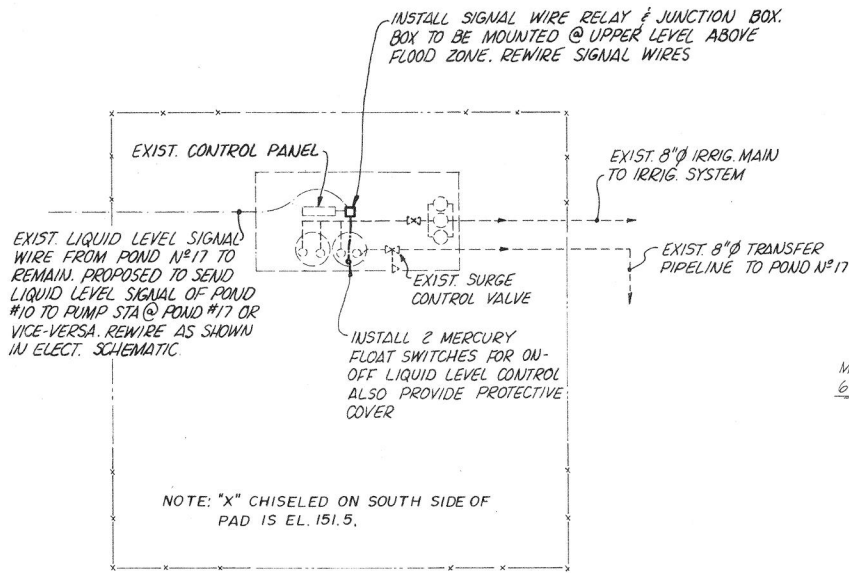

NOTE: "X" CHISELED ON SOUTH SIDE OF PAD IS EL. 151.5.

PUMP STATION SCHEMATIC @ POND 10
SCALE: 1"=10'

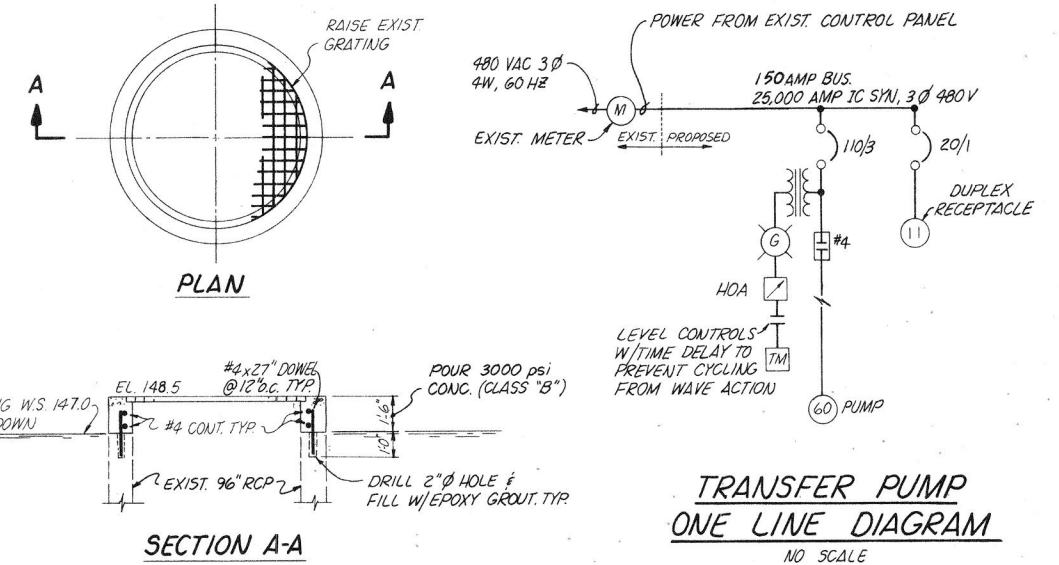

TRANSFER PUMP ONE LINE DIAGRAM
NO SCALE

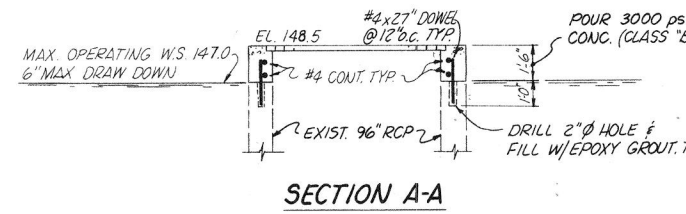

SECTION A-A

DETAIL 3
SCALE: 1/4"=1'

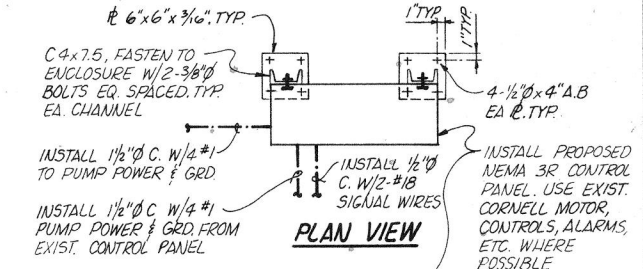

PLAN VIEW

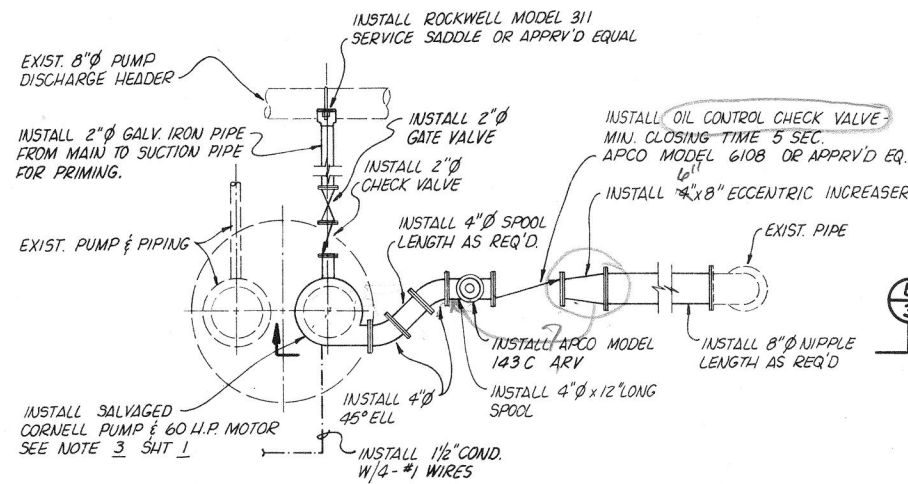

TRANSFER PUMP INSTALLATION DETAIL
SCALE: 1/2"=1'

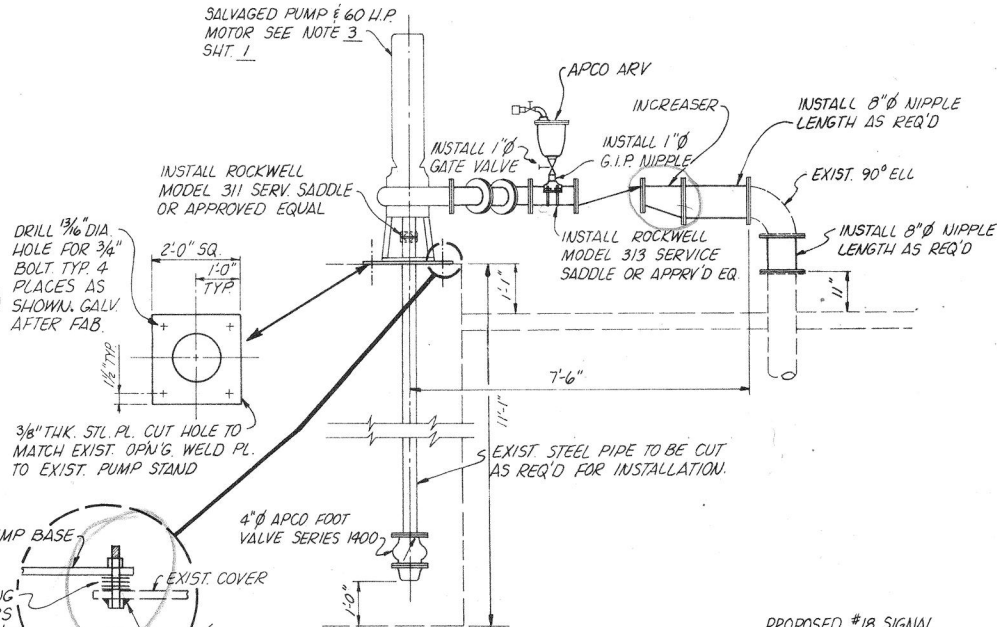

SECTION B
SCALE: 1/2"=1'

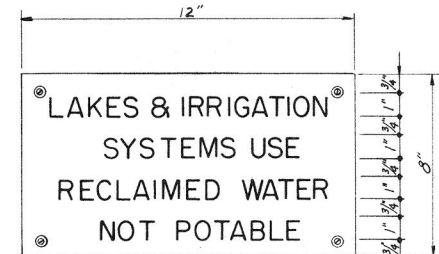

SPEC'S
SIZE: 8" x 12"
COLOR: #12 RED BACKGROUND W/WHITE COPY
FINISH: FUSED PORCELAIN CERAMIC
MOUNTING: FOUR GROMMETED HOLES FOR #10 FASTENER
END USE: EXTERIOR
STEEL: 18 GAGE VITREOUS ENAMELING STOCK
MFR: FERRO ENAMELING CO. OR EQ.

NOTE: MADE IN ACCORDANCE W/PORCELAIN ENAMEL INSTITUTE SIGN SPEC. PEI: 5-103 CURRENT EDITION.

SIGN DETAIL
NO SCALE

NOTE: KEY INTERLOCK-
ONLY ONE SWITCH HANDLE SHALL BE PROVIDED, & KEYED SUCH THAT THE HANDLE CAN ONLY BE REMOVED IN THE LEVEL CONTROL POSITION. THIS INTERLOCK IS REQ'D SO THAT THE TWO MOTOR CONTROL CIRCUITS CAN NOT BE INTERRIED

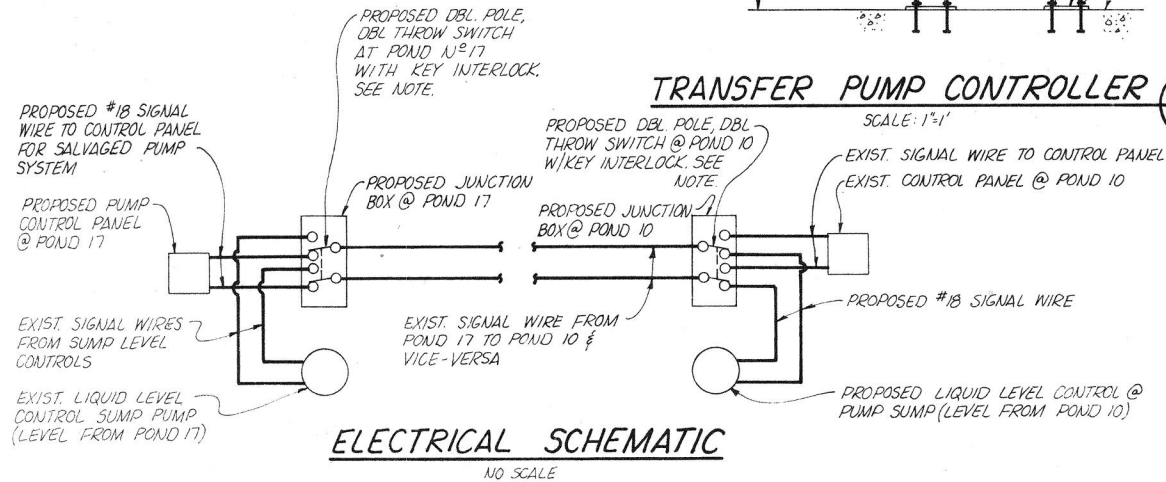

ELECTRICAL SCHEMATIC
NO SCALE

TRANSFER PUMP CONTROLLER
SCALE: 1"=1'

DRAWN BY: MDH DESIGN BY: EAL

CHECK BY: KCG

BY:

REVISION	DATE	DESCRIPTION

RVA RAYMOND VAIL AND ASSOCIATES
ENGINEERING • PLANNING • SURVEYING
SACRAMENTO, CALIFORNIA 1410 Ethan Way 95825

PROPOSED IMPROVEMENTS FOR
SOUTH GOLF COURSE IRRIGATION SYSTEMS
DETAILS

DATE: FEB. 1983 SHEET: 3 OF 3
SCALE: AS NOTED
HORIZONTAL: AS NOTED
VERTICAL: AS NOTED
W.O. NO. 1205.11T SHEETS: 3

Appendix G – Dust Control Guidelines



Rancho Murieta Community Services District (District)

Dust Control Guidelines

ALLOWED USE
The California Code of Regulations, Title 22 Section 60307(b) (6) allows for the use of recycled water for dust control on streets and roads. In addition, this Dust Control Guideline has been approved by the California Department of Public Health (pending CDPH approval) for dust control. Recycled water is NOT allowed for drinking, washing, or animal water supply.
REQUIREMENTS FOR USE
Vehicles used for collecting and distributing recycled water for dust control shall: <ul style="list-style-type: none">• Have an adequate tank and plumbing system to ensure that leaks and ruptures will not occur due to normal use.• Be equipped with either two risers, one for potable water and one for recycled water, or each tank used shall be equipped with a District-approved air-gap separation between the filler tube and the tank.• Have color-coded risers, hoses, and fittings; blue for potable water and purple for recycled water.• Be equipped with uniquely sized fittings to prevent accidental connection between the potable water and recycled water systems.• Be equipped with spray heads/nozzles configured to minimize runoff, ponding, and drift.• Be equipped with control valves configured such that recycled water can be applied in a controlled fashion on the site and completely retained during transit.• Be clearly labeled as specified in the "Signage Requirements."• Prior to use, the District will inspect the Users' vehicles to ensure compliance with the requirements listed above.• Each vehicle tank used to store and/or transport recycled water must be flushed and disinfected prior to storage and/or transport of potable water or recycled water of higher quality.• User must maintain a log recording details of all recycled water deliveries (date, location, volume, and end use).• Any storage facility containing recycled water for reuse applications shall be managed in a manner to control odor.• Sites shall be designed and operated using Best Management Practices (BMPs) as stated below, or as revised by the District to prevent recycled water spray, mist, or surface flow from either leaving the site or reaching:<ol style="list-style-type: none">1. Any storm drain or surface water with year-round flow located adjacent to the site;2. Areas with public access (e.g., dwellings, designated outdoor eating areas, or food handling facilities); and3. Drinking fountains, unless specifically protected with a shielding device.
BEST MANAGEMENT PRACTICES
<ul style="list-style-type: none">• For dust control adjacent to surface waters, install runoff barriers, such as vegetative strips, collection system, or 100-foot buffers.• Maintain distance buffers if applying recycled water near sensitive land uses.• Do not apply recycled water for dust control during strong winds.• The application method must not cause ponding of water. For example, avoid excessive application volumes, use after heavy rains, or application to excessively uneven (sloped) areas.

- Recycled water must not run off the site where it is intended to be applied. Conduct visual inspections to determine the necessary delivery rates and volumes. If runoff cannot be restricted by application method (for example, if the ground surface is sloped or the soil has low water permeability), runoff needs to be collected via a drainage system and reapplied.
- If hand washing is used, keep the hose low to the ground and point it in the direction of the wind to prevent spray drift.
- Signage should be displayed at site of storage, during watering, and while the area is still wet (see "Signage Requirements" on next page).
- When watering is completed, drain hose and return hose to secure position. Ensure that there is no risk that recycled water may be used for drinking purposes or animal water supply.

HEALTH AND SAFETY GUIDELINES

- All workers that are likely to be present during dust control activities are required to have training in the proper use of recycled water. Supervisory personnel and Site Supervisors shall be held accountable for ensuring that employees are using recycled water properly.
- It is the responsibility of the User to train all operations personnel so they are familiar with the proper use of recycled water. Training for operations personnel should include, but not be limited to, awareness of the following:
 1. Working with recycled water IS SAFE if common sense is used and if appropriate regulations are followed.
 2. Recycled water, although highly treated, is non-potable.
 3. Conditions such as ponding and runoff are not allowed.
 4. Good personnel hygiene must be followed (e.g., wash hands immediately after working with recycled water, do not consume food or drink while working with recycled water, cover wounds to prevent contact with recycled water).
 5. Cross-connections between the recycled water system and the potable water system must not be allowed to exist at any time.

Report any accidental spills of recycled water or personnel hygiene issues that have received medical attention to the Rancho Murieta Community Services District for action and record keeping. RMCSD will initiate normal incident management procedures.

SIGNAGE REQUIREMENTS

Vehicle Mounted Recycled Water Storage Tanks

While using vehicle-mounted recycled water for dust control, the User must install, maintain, and keep in place three magnetic signs (on both sides and the rear of each vehicle, at the outlet) indicating that recycled water is in use. The signs must contain the words: "RECYCLED WATER – DO NOT DRINK" in 2-inch high letters on a purple background and the "Do Not Drink" symbol, as illustrated in Recycled Water Standard Detail RW-16.

Other Equipment and Devices

All stationary pipe, materials, and equipment used to carry recycled water onsite (such as pipes, air vacuum relief valves, pressure reducing valves, pumps, pump control valves, etc.) must be properly identified in accordance with the District's Recycled Water Standards.

USER AGREEMENT

All potential recycled water users in Rancho Murieta must meet the District's requirements and must enter into a written agreement with the RMCSD. RMCSD reserves the right to take any action necessary, with respect to the operation of the User's onsite recycled water operations, in order to safeguard public health and to meet applicable regulations and permits.

MEMORANDUM

Date: November 7, 2013
To: Board of Directors
From: Improvements Committee Staff
Subject: Approve Sacramento Air Quality Management District Generator Permit Fees

RECOMMENDED ACTION

Approve up to \$5,618 to the Sacramento Air Quality Management District for permit fees for a standby diesel generator, funding to come from Water Replacement Reserves. This is part of the Water Treatment Plant Expansion Project.

BACKGROUND

As part of the work necessary to complete the Water Treatment Plant #1 expansion, an Authority to Construct Permit and fees need to be filed with the Sacramento Air Quality Management District (SAQMD). The fee is based on the size of the generator to be installed. Current design has the generator at 1100 kw, however it may be downsized to 750 kw pending HDR revisions. Requirements for fees for a diesel fired standby engine are listed below, copied from the SAQMD website.

308.8 SCHEDULE 7, INTERNAL COMBUSTION ENGINE HORSEPOWER SCHEDULE:

Any equipment using internal combustion engines as a power source shall be assessed a permit fee based on the cumulative total rated horsepower of all internal combustion engines included, in accordance with the following schedule:

Horsepower	Initial Permit Fee	Permit Renewal Fee
Less than 50	\$ 350	\$ 175
50 to 249	\$ 702	\$ 350
250 to 499	\$1,404	\$ 702
500 to 999	\$2,809	\$1,404
1000 or greater	\$5,618	\$2,809

Although the costs are below the General Manager's approval authority, to keep with good accounting practices, all costs related to reserve expenditures must be brought before the Board for approval.

The Improvements Committee recommends approval.

MEMORANDUM

Date: November 11, 2013
To: Board of Directors
From: Paul Siebensohn, Director of Field Operations
Subject: Approve Sacramento Municipal Utilities District New Services Commitment Application Fee

RECOMMENDED ACTION

Approve \$5,000 to Sacramento Municipal Utilities District (SMUD) for a new service commitment. Funding to come from Water Replacement Reserves. This is part of the Water Treatment Plant Expansion Project.

BACKGROUND

As part of the work necessary to complete the Water Treatment Plant Expansion Project, the electrical service from SMUD needs to be increased to accommodate the increase in power. This increase is related to the plant production flow increasing from 1.5 MGD to 6.0 MGD, at full build out, with motors and appurtenances needed to operate the plant.

This cost has already been approved and processed through at General Manager's level in an effort to keep the project on schedule. Attached is a copy of the notice with SMUD's rates. SMUD has received the application, coordinated through HDR Engineering for electrical design, and is in the process design with SMUD.

Although the costs are below the General Manager's approval authority, to keep with good accounting practices, all costs related to reserve expenditures must be brought before the Board for approval.

SERVICE INFORMATION PACKAGE

COPY

June 2, 2009

Thank you for your interest in receiving electric service from SMUD. The following information is provided in an effort to ensure your project is given the best service possible. In order to provide this service, certain requirements must be met to avoid delays and provide a smooth transition from design to construction and the final connection of your new service. Those requirements as well as a summary of the events that will follow are described below.

Electric Service Commitment

Description: A project specific plan, required by local permitting agencies, for electrical service detailing SMUD's requirements and the developer's responsibilities.

A New Services Commitment is dependent on the following:

- 1 A completed "*Customer Application for Service*" form (see attachment A).
- 2 A completed "*Project Information Form*" along with requested information / plans (see attachment B and C).
- 3 A non-refundable design deposit (please see below).

Effective January 1, 1996, SMUD began charging projects served under Rule 16 a nonrefundable design deposit. This includes mixed-use (combinations of commercial and residential) developments. A non-refundable design deposit is required before a commitment will be given and is determined as follows:

Secondary work only	\$5,000
Primary work - basic fee*	\$5,000
Downtown Sacramento	\$10,000
*If non-basic application contact SMUD Designer at 916-732-5700	

Please Note:

SMUD commitments are prioritized based on receipt of the above information and are valid for 12 months. Commitments older than 12 months require review and possible redesign by SMUD. Customer design changes that result in more than one redesign will require an additional non-refundable design deposit and may cause significant delays in design and construction scheduling.

Once a commitment for electric service has been completed for your project you may schedule a pre-construction meeting with a SMUD inspector. At the time of your pre-construction meeting you will need to supply the inspector with a copy of your building permit and a valid electrical service need date. Inspection of SMUD's required civil improvements cannot begin without these items.



SMUD

SACRAMENTO MUNICIPAL UTILITY DISTRICT

The Power To Do More.™

MEMORANDUM

Date: November 14, 2013
To: Board of Directors
From: Edward R. Crouse, General Manager
Subject: Discuss New North Gate Funding Request by Rancho Murieta Association

RECOMMENDED ACTION

Provide direction to staff on how to proceed in relation to negotiations with Rancho Murieta Association (RMA) concerning District funding of barcode scanner, cameras and gate arm equipment for the new North Gate.

BACKGROUND

Following direction from last month's Improvements Committee meeting, I met with Greg Vorster, General Manager, Rancho Murieta Association (RMA), to discuss the District's participation and funding assistance with the New North Gate. Our discussions were fruitful and we reached a mutual understanding of each other's funding constraints and limited assistance.

That said, given recent discussions with the RMA North Gate Committee and John Sullivan and his development team on their vision of the new North Gate design concepts, our discussions were put on hold until a new plan is developed and construction costs are estimated.

It is my opinion that the original budget of \$1.4+ million is sufficient to cover the basic north gate improvements, including the electronic gate access system for the full build out scenario, all inclusive. In addition, and in support of my opinion, it is my understanding the water features are no longer a part of the current project and all ancillary branding features and structures are being paid for by the new developer.

As for our water treatment plant (WTP) road mitigation fee, I sent Greg a suggested method to calculate the fee, but also suggested some Board members opined we should not pay the fee as we have common area and road access rights and maintenance easements from the final maps for all the subdivisions. Since we need to keep funds separate, the District cannot take funds from the Water Department for use in the Security Department, although when the fees are paid to RMA, it is up to their discretion on how to use those funds.

On a similar note, I sent Greg a fee estimate for the future Escuela site, based on projected water demand for a school as a general ball park range of the fee. Ultimately, the final fees will be based on water demand for their final project. Likewise, we cannot barter those fees since they are water fund related.

Chief Remson is re-evaluating the condition of the existing equipment for reuse or replacement at the New North Gate. We will share those results with RMA when they are available.

MEMORANDUM

Date: November 14, 2013
To: Board of Directors
From: Security Committee Staff
Subject: Approve the Surveillance Camera Implementation, Integration, and Expansion Plan

RECCOMENDED ACTION

Approve the 2013 Surveillance Camera Implementation, Integration and Expansion Plan.

BACKGROUND

The Security Department, in an effort to use updated technology throughout the District to enhance public safety, has developed a Surveillance Camera Implementation, Integration, and Expansion Plan. The use of surveillance cameras can help deter criminal acts, unwanted activity, be used for prosecution and restitution, and enhance patrol operations.

Since the draft plan was submitted to the Security Committee for comment on July 5, 2013, Greg has met with various surveillance camera vendors and received suggestions and input from business owners, Board and Committee members, local law enforcement, and other community members. He has also participated in "field trips" to Mule Creek State Prison and the Natomas Park Master Association to observe their surveillance camera systems.

After speaking with five (5) security camera vendors, two (2) submitted proposals for a community wide system. One of the plans was very detailed and expensive, using a microwave system. One was a standard system using Rancho Murieta Association (RMA) cable and wireless to cover areas without power, telephone or cable.

The District presently intends to provide cameras only on District owned property and facilities. There are streets that are open to the public, including Murieta Drive, Cantova Way, and Lone Pine Drive that would benefit from surveillance cameras. These cameras could be located on District property, including lift stations and the Lone Pine water tank, on street lights, and/or at entrances to business parking lots.

Greg's recent focus has been on getting information and costs on a surveillance camera viewing system that can be used at the North and South gates and the patrol vehicle laptop. This would allow businesses to connect to the District's system to allow surveillance viewing. This would not be a full time monitoring system where the cameras are watched at all times. This viewing system would be used to "spot check" businesses and areas, observe areas when the Security Department is notified of in-progress incidents, and for after the fact viewing of an incident.

Greg has met with three (3) vendors in regards to this and has received two (2) proposals with costs between approximately \$2,000 and \$11,000. He should get the third proposal in the next two weeks. These proposals include installing new hardware at the gates and on the patrol laptop, which would include new monitors and computers, along with new software to view the surveillance video. Since there are multiple systems in the community, some systems may require additional hardware (encoders) and software to allow viewing by the Security Department. The vendors are putting together a “standard” for cameras that would allow seamless integration between the various systems and the District’s system.

The cost for the District only viewing system is estimated to be \$25,000 to \$30,000.

Presently, the District has not budgeted for a surveillance camera system. Funding options could include using operating expenses and future Security Impact Fees.

Each separate entity would be responsible for acquiring, operating, and maintaining their individual surveillance camera systems that would be compatible with the District’s viewing system. The District would have no responsibility or guarantee for 24 hour monitoring, recording of video, camera operation, vandalism to equipment, or incidents that occur under a surveillance camera view.

The next step for the District is to finalize the Surveillance Camera Implementation, Integration and Expansion Plan, determine a budget to implement a viewing system, get Board approval for the expenditures, and install the viewing system.

The Security Committee recommends approval.



“Serving Our Community”

Rancho Murieta Community Services District
Rancho Murieta Security Department

**Preliminary
(DRAFT)**

**Surveillance Camera
Implementation, Integration and Expansion Plan**

November 2013

Table of Contents

1. Executive Summary
2. Issues/Problems
3. Goal
4. Solutions
5. Evaluation of Pros and Cons of Solutions
6. Present Surveillance Camera Locations
7. Proposed Surveillance Camera Locations
8. Power/Infrastructure Needs
9. Vendor Selection
10. Monitoring Option
11. Costs/Responsibilities of Solutions
12. Policy and Procedures
13. Budget
14. Funding
15. Schedule

DRAFT

Surveillance Camera Implementation, Integration and Expansion Plan

Preliminary

1. Executive Summary

Security and law enforcement continually seek new and updated technology to enhance public safety. In that effort, technology, specifically surveillance cameras, can be used throughout the Rancho Murieta Community Services District (District) to act as a deterrent to crime and unwanted activity and to use in the prosecution of and/or restitution by those responsible. The use of surveillance cameras is part of the District's Security Strategic Plan.

The public use of surveillance cameras can deter criminal acts and other unwanted activity if the public knows that they are being watched and there is the possibility of identification and apprehension. An additional benefit is the law abiding public may feel safer and more comfortable using parks, streets, and other public areas.

Security Patrol Officers and local law enforcement cannot be in all areas at all times within the District. The Security Department will use surveillance cameras to enhance the patrol operations with the ability to monitor multiple areas within the District and use the patrol resources more effectively. The use of surveillance cameras helps keep the community a safe and comfortable place to live, work, and play.

In discussions with local law enforcement, including the Sacramento County Sheriff's Department Patrol Supervisor and Crime Prevention Specialist for the Rancho Murieta area, they support the use of surveillance cameras and alarms for residences and businesses. The footage is used for identification, restitution and prosecution. There is a consensus that surveillance cameras are a good tool, they should be monitored for quick law enforcement/security response, and the video can be used as evidence in court. Video quality is thought to be very important. For example, less expensive camera systems may only show a grainy shot of someone in a white shirt, when a high quality system can show much more detail of a person, vehicle, or event.

Presently, surveillance cameras are located at the North and South Gates, Stonehouse Park, Riverview Park, Water Treatment Plant, Wastewater Reclamation Plant, Rancho Murieta Country Club (RMCC), and some commercial properties.

Additional areas for the future use of surveillance cameras include Clementia Park, Bass Lake, Granlees Beach, Murieta Plaza, Murieta Village, Equestrian Center, streets, intersections and other businesses in the community.

2. Issues/Problems

Unwanted activities, including rule violations and crimes such as vandalism, theft and malicious mischief have been occurring within the District. The vast majority of these incidents have occurred within the main residential areas, but unwanted activity also occurs District wide. Security Patrol Officers, along with Sacramento Sheriff's Deputies (SSD), strive to prevent and deter these issues by patrolling the District in marked, visible patrol vehicles. When unwanted activities, rule violations and crimes occur, District Security and SSD strive to hold those responsible for the acts.

3. Goal

To decrease crime and unwanted activities within the District by the increased use of surveillance cameras. The use of surveillance cameras can act as a deterrent and assist the District's Security Department and outside law enforcement in identifying those responsible for crimes and unwanted activities. To achieve this goal, additional surveillance cameras and equipment are needed. Surveillance cameras have been used in the past to identify suspects who have committed crimes and rule violations. They have been used recently at Riverview Park, Stonehouse Park and the Water Treatment Plant. This has been after the fact viewing of surveillance video.

4. Solutions

1. Add additional surveillance cameras throughout the District. Implement a system that allows viewing of surveillance video by Security Patrol Officers in the field and in the North and South Gates. This would aid Security Patrol Officers and Security Gate Officers in viewing areas for unwanted activity and allow better use of patrol resources.
2. Increase video viewing at the North and South Gates and Security Patrol laptop. The Gate Officers' primary duty is to follow the RMA Gate Policy. This, along with other requirements, does not allow the Officers to constantly monitor surveillance video. To assist the Patrol and Gate Officers, an offsite, third party monitoring and alert or notification system could be in place to notify Patrol and Gate Officers of any activity caught by a surveillance camera. This could be accomplished by a flashing screen or beeping notification to alert the Gate and Patrol Officers for response.
3. Integrate new and existing systems throughout the District. This would include the ability to view surveillance video at the North and South Gates and the Security Patrol laptop computer. Some new and existing systems have proprietary software. These will need to be integrated with the Gate and Patrol computers to allow a seamless and easy to use system. This will provide event-driven surveillance video, reducing the need for Patrol and Gate Officers to constantly monitor video screens, to be used in concert with third party monitoring.

5. Evaluation of Pros and Cons of Solutions

- Pros
 - The ability to monitor areas throughout the District for crimes, rule violations, and unwanted behavior.
 - To act as a deterrent and to have video evidence for prosecution and restitution.
 - To assist Security Patrol Officers to more efficiently patrol the District by having the ability to view areas for activity, without having to drive to these areas. This may reduce staffing needs.
- Cons
 - The “Big Brother” effect of having the Security Department and others watch people and areas as they go about their lives in public places.
 - The implementation, operations and maintenance costs are presently unknown, and can take funds away from other budget areas.
 - Monitoring- the possibility of delayed response and after the fact response due to the Patrol and Gate Officers not monitoring surveillance video screens full time.

6. Present Surveillance Camera Locations

- District
 - North and South Gates- Murieta Parkway and Murieta South Parkway
 - Water Treatment Plant- Lake Clementia
 - Wastewater Reclamation Plant- Jackson Road behind District office
 - District Office- 15160 Jackson Road
- Rancho Murieta Association
 - Stonehouse Park- Escuela Drive, North residential
 - Riverview Park- Reynosa Drive, South residential
 - Laguna Joaquin Park- Gazebo, North residential
 - Camera presently inoperable
- Rancho Murieta Airport- Murieta Drive
- Rancho Murieta Country Club- Alameda Drive
- Rancho Murieta Country Store- Murieta Drive
- OE3 Joint Apprenticeship- Cantova Way
- Various commercial businesses
 - Some commercial properties have been contacted regarding their use and needs
 - Most have “stand alone” systems that allow IP viewing
 - Most have their own camera vendors
 - Some are ready to upgrade their systems

- Some are not interested at this time due to lack of issues/problems/funds

7. Proposed Surveillance Camera Locations

These new locations are properties and facilities that are susceptible to theft and vandalism. Additional areas are parks and public areas that are not only susceptible to theft and vandalism, but also where public safety issues can be monitored.

- District
 - Cosumnes River Pump Station- Cosumnes River at Granlees Dam
 - Water Tank- Lone Pine Drive
 - Water Tank- Van Vleck Ranch
 - North & South Gate upgrades
- Rancho Murieta Association
 - Laguna Joaquin Park- Gazebo, North residential
 - Clementia Park- Lake Clementia
 - Granlees Beach- Cosumnes River
 - Office- Murieta Parkway
 - Maintenance Yard- Escuela Drive
 - Lake Calero/Chesbro/Bass Lake- North back area
 - Pedestrian Bridge- Cosumnes River, 2nd Green North & 2nd Fairway South
- Commercial businesses
 - Primarily outside locations
- Street Light Poles
 - To provide street view- Murieta Drive/Lone Pine Drive/Cantova Way
- Portable/Moveable Cameras
 - Street light poles
 - Trees
 - Streets/intersections
 - Parks
- Existing surveillance camera locations may be enhanced by additional cameras and/or upgraded cameras.

8. Power/Infrastructure Needs

- Power/telephone/cable is not available at all sites.
 - These sites include
 - Cosumnes River Pump Station- power only
 - Water Tank-Lone Pine Drive- power only
 - Water Tank-Van Vleck Ranch- power only
 - Clementia Park- power only
 - Granlees Beach- power only (from Cosumnes River Pump Station)

- Lake Calero/Chesbro/Bass Lake- power only
 - Pedestrian Bridge- no power/telephone/cable
- To provide power/telephone/cable
 - Cable installation
 - Solar installation
 - Wireless systems
- Internet and cable needs should be addressed
 - Present District internet will not support constant surveillance video stream
 - District needs to use RMA broadband to allow for potential high video stream viewing
- To overcome these deficiencies, the camera system should be compatible with wireless connectivity and future cable connectivity.

9. Vendor Selection

Five (5) vendors have been provided with basic information on the desire to increase surveillance video use. Included was the purpose, problems/issues, solutions, present cameras locations, the commercial properties, proposed camera locations, types of cameras, infrastructure needs, monitoring, cost as well as a site tour. Proposals were requested for, at a minimum, site and product recommendations, system proposals, equipment location, and network recommendations.

10. Monitoring Options

- An outside company could be used to monitor surveillance video
 - Guidelines would be put in place to allow notification
 - Cost would be divided between those using the system
- An additional Security Officer could be hired to monitor surveillance video
 - Cost would be divided between those using the system

11. Costs/Responsibilities of Solutions

Each separate entity would be responsible for acquiring, operating and maintaining their individual systems that would be compatible with the District's viewing system. The District would have no responsibility or guarantee for monitoring, recording, camera operation, vandalism to equipment, or incidents that occur under surveillance camera view.

12. Policy and Procedures

Policy and Procedures will be written to address use, viewing, and access. These areas include storage and deletion. Since public areas may be viewed, a policy should be in place to address these areas to ensure the video is used for the intended purpose.

13. Budget

- Based on proposals received, the cost for the District's viewing system is approximately \$25,000, to account for software, hardware, monitors and unknowns.
- Additional cameras for District would include the Cosumnes River Pump Station, the water tanks on Lone Pine Drive and Van Vleck Ranch, and various lift stations at a cost of \$20,000 to \$30,000, depending on the number of cameras and their capabilities.
- Operation and maintenance costs could be \$5,000 to \$10,000 for upgrades and replacement.

14. Funding

- No funds have been identified or budgeted. Options could be using the operating budget and future Security Impact Fees.

15. Schedule

- Irrespective of funding, acquisition and installation of the District's viewing system is about 1-2 months.

MEMORANDUM

Date: November 14, 2013
To: Board of Directors
From: Edward R. Crouse, General Manager
Subject: Report Back on the 670 Financing and Services Agreement

RECOMMENDED ACTION

Receive staff update on the 670 Financing and Services Agreement.

BACKGROUND

In late October Jon Hobbs prepared language revisions suggested by the Board which were forwarded to Les Hock for the group's review.

The 670 Group generally disagreed with the suggested language. We are working on resolving their concerns, to the extent more dialogue is successful.

We will brief the Board in Closed Session in more detail regarding our discussions and progress.

MEMORANDUM

Date: November 15, 2013
To: Board of Directors
From: Darlene Gillum, Assistant General Manager
Subject: Discuss Water Treatment Plant Expansion Financing Alternatives

RECOMMENDED ACTION

Authorize District staff to enter into negotiations with US Bank for a loan of up to \$3,000,000 for a 7 year term, principal payment amortized over 15 years and a balloon payment of \$1,600,000 at the end of the loan term (Option #2).

BACKGROUND

We have been working with representatives from CSDA Finance Corporation and US Bank on financing alternatives for the Districts portion of the cost for the Water Treatment Plant (WTP) Expansion and Upgrade Project. Wells Fargo is still interested in presenting financing options which will hopefully be provided before the November Board meeting.

Since the total actual cost of the project is yet to be determined (based on the competitive bid process results), and based on recommendation from the Finance Committee: 1) the principal loan amount used in this comparison has been selected at \$3,000,000; and 2) while it is expected that some portion of available reserves will be used toward payment of the debt incurred by the District, that amount is not being considered in this analysis. Once the final cost is determined, the Board will have the opportunity to approve the best use (i.e., use 100% up front as down payment, use throughout the term of the loan to cover payment shortage, use to pay the balloon at the end of the loan term, etc.) and the amount of reserves to be used.

The following chart is a summary of the financing options currently being reviewed. There are four (4) options for consideration:

CSDA Finance Corporation

Option #1 – CSDA Finance Corporation is offering a Lease-Purchase type loan for a 20 year term with a fixed interest rate of 4.15%. There is an early purchase option available at the end of year seven of \$2,268,340, which reduces the total interest paid from \$1.47m to \$834,150; a savings of \$635, 850. Total cost, if the purchase option is exercised in year seven, is \$3,834,150.

US Bank

Option #2 – US Bank is offering a Non-revolver type loan. The Non-revolver works similar to a Construction Loan where the District would make draws against the approved principal of \$3,000,000 throughout the construction period. At the end of construction, the loan principal would be capped at the amount drawn and interest would then be paid on that amount. The loan term is for 7 years with the principal

payment amortized over a 15 year period which reduces the annual payments but results in a balloon payment at the end of the loan term of \$1,600,000. It has a variable rate of 2.6% adjusted by either the Prime or Libor. The annual adjustment would be capped. There is no prepayment penalty.

Option #3 – This loan is for a 7 year term with a variable rate of 2.6%, adjusted by either the Prime or Libor. The annual adjustment would be capped. There is no pre-payment penalty. This option amortizes the principal payment over the original 7 year term.

Option #4 – This loan is for a 7 year term with a variable rate of 2.6%, adjusted by either the Prime or Libor. The annual adjustment would be capped. There is no pre-payment penalty. This option is interest only with a balloon at the end of the loan term of \$3,000,000.

	Option #1	Option #2	Option #3	Option #4
	CSDA Finance Corporation	US Bank	US Bank	US Bank
Funding Type	Lease - Purchase	Non-Revolver	Non-Revolver	Non-Revolver
Principal Amount	\$3,000,000	\$3,000,000	\$3,000,000	\$3,000,000
Interest Rate	4.15%	2.60%	2.60%	2.60%
	Fixed	Variable	Variable	Variable
Term	20 years	7 years	7 years	7 years
Amortization Period		180 months	84 months	84 months
Average Annual Payment	\$223,687.21	\$262,400	\$473,143	\$78,000
Balloon Payment		\$1,600,000	\$0	\$3,000,000
Total Interest Paid	\$1,473,744.20	\$436,800.00	\$312,000.00	\$546,000.00
Required Monthly Charge for repayment	\$7.21	\$8.46	\$15.77	\$16.89
Current Charge for Debt Prefunding (avg base and usage in 2013-2014)	\$4.64	\$4.64	\$4.64	\$4.64
Variance	\$2.57	\$3.82	\$10.61	\$12.25
Anticipated rate per the Debt Service Prefunding Plan as modified in 2013 - 2014 Budget process	\$7.09	\$7.09	\$7.09	\$7.09
Variance	\$0.12	\$1.37	\$8.16	\$9.80

June 20, 2014 Estimated Balances

Debt Service Reserves \$ 285,000.00
 Water Capital Replacement Reserves \$2,866,860.00

Recommendation to use \$1.5m from Reserves

The options highlighted in blue above were selected as the two (2) best alternatives for consideration. Options 3 and 4 were not selected for the following reasons:

Option #3 was not selected because the required monthly rate charged to residents in order to make the annual debt service payment is estimated to be around \$15.77.

Option #4 was not selected because the required monthly rate charged to residents in order to pay the annual interest payment and the balloon of \$3,000,000 would need to be \$16.89.

The attached chart shows the estimated impact to the monthly bill for both options 1 and 2. There are two estimates for each option: the first estimate shows the impact of the current debt service prefunding amount being replaced by the required debt service charge; the second estimate shows, in addition to the replacement of the debt service prefunding charge by the debt service charge, the impact of the elimination of the Sewer Debt Service Prefunding for the VVR Permanent Irrigation Fields (this monthly charge may be eliminated if the District is successful in obtaining a Master Reclamation Permit but this will not be known until late 2014).

Staff is recommending Option #2 be approved by the Board for financing of the WTP1 Expansion and Upgrade. This option is being recommended because the overall cost to the District is less than Option #1, \$3,436,800 versus \$4,473,744 respectively, and there is no prepayment penalty at any time during the loan term which allows the District to take advantage of the best timing and use of available reserves. The chart below shows the historical trends of the Prime and Libor rates since January 2001. The LAIF interest rate is also shown as an indicator of returns earned during the same time frame. Staff feels that there is low risk at the current time of a variable rate.

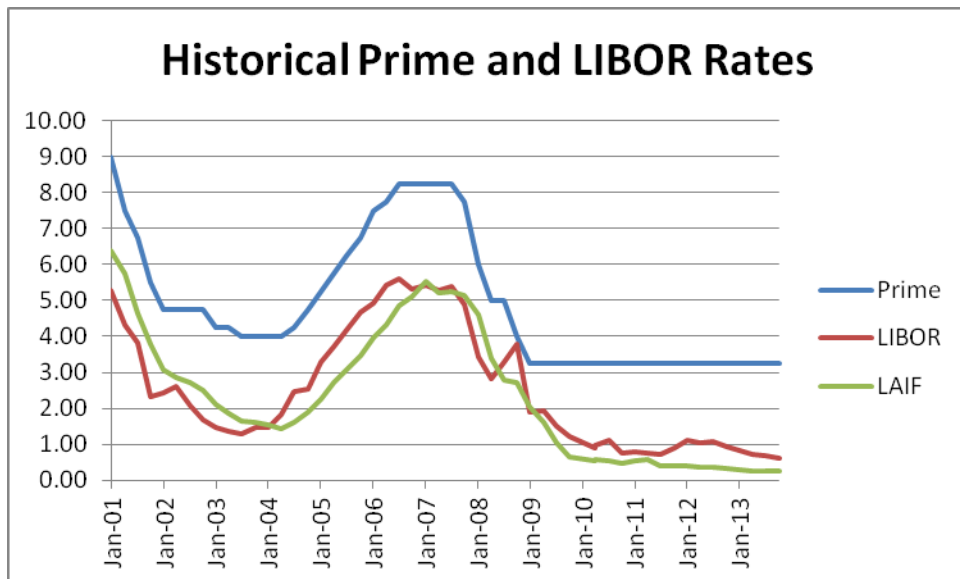

Even though staff is recommending option #2, if the Board is uncomfortable with a variable rate loan or if the Board feels the estimated monthly rate of \$8.46 is too high, Option #1 would be the recommended choice.



RANCHO MURIETA COMMUNITY SERVICES DISTRICT
WTP1 Financing Alternatives - estimated impact to monthly bill

Lease-Purchase (CSDA Finance Corp)
 \$3.0mm, 4.15% fixed, 20 yr term
 Pre-payment allowed in yr 7

Non-Revolver (US Bank)
 \$3.0mm, 2.6% variable, 7 yr term, Balloon of \$1.6mm
 No pre-pymt penalty, Adjusted by LIBOR or Prime

Average Monthly Customer Bill		Current Monthly Rates July 1, 2013	Estimated Rates	Change	Estimated Rates	Change	Estimated Rates	Change	Estimated Rates	Change
Residential Metered Lot										
Water	CF									
Average Usage in CF	1957									
Residential Usage										
Usage Charge (\$.0140 per CF)		27.40	27.40	-	27.40	-	27.40	-	27.40	-
Debt Service Prefunding (\$.0012 per CF)		2.35	0.00	(2.35)	0.00	(2.35)	0.00	(2.35)	0.00	(2.35)
Residential Base										
Residential Base		28.53	28.53	-	28.53	-	28.53	-	28.53	-
Debt Service Prefunding		2.25	0.00	(2.25)	0.00	(2.25)	0.00	(2.25)	0.00	(2.25)
Reserve Contribution		6.39	6.39	-	6.39	-	6.39	-	6.39	-
Debt Service Payment		0.00	7.21	7.21	7.21	7.21	8.46	8.46	8.46	8.46
Water Total		66.92	69.53	2.61	69.53	2.61	70.78	3.86	70.78	3.86
Sewer										
Residential Base		37.59	37.59	-	37.59	-	37.59	-	37.59	-
Debt Service Prefunding - Perm Irrig Fields		3.15	3.15	-	0.00	(3.15)	3.15	-	0.00	(3.15)
Reserve Contribution		6.81	6.81	-	6.81	-	6.81	-	6.81	-
CDO Reimbursement		1.92	1.92	-	1.92	-	1.92	-	1.92	-
Sewer Total		49.47	49.47	-	46.32	(3.15)	49.47	-	46.32	(3.15)
Solid Waste (avg. 64 Gallon Container)		20.30	20.30	-	20.30	-	20.30	-	20.30	-
Security Tax (Maximum Tax Ceiling \$24.87)		25.93	25.93	-	25.93	-	25.93	-	25.93	-
Drainage Tax (Maximum Tax Ceiling \$4.37)		4.64	4.64	-	4.64	-	4.64	-	4.64	-
		\$167.26	\$169.87	2.61	\$166.72	(0.54)	\$171.12	3.86	\$167.97	0.71
				1.56%		-0.32%		2.31%		0.42%

* Assumes that the District is successful in obtaining the Master Reclamation Permit, which eliminates the need to continue the collection of Sewer debt service prefunding
 This is the ultimate goal of the District, however, it will not be known until late 2014 if we are successful.

Murieta Village Lot

Water	CF									
Average Usage in CF	518									
Residential Usage										
Usage Charge (\$.0140 per CF)		7.25	7.25	-	7.25	-	7.25	-	7.25	-
Debt Service Prefunding (\$.0012 per CF)		0.62	0.00	(0.62)	0.00	(0.62)	0.00	(0.62)	0.00	(0.62)
Residential Base										
Residential Base		28.53	28.53	-	28.53	-	28.53	-	28.53	-
Debt Service Prefunding		2.25	0.00	(2.25)	0.00	(2.25)	0.00	(2.25)	0.00	(2.25)
Reserve Contribution		6.39	6.39	-	6.39	-	6.39	-	6.39	-
Debt Service Payment		0.00	7.21	7.21	7.21	7.21	8.46	8.46	8.46	8.46
Water Total		45.04	49.38	4.34	49.38	4.34	50.63	5.59	50.63	5.59
Sewer										
Residential Base		37.59	37.59	-	37.59	-	37.59	-	37.59	-
Debt Service Prefunding - Perm Irrig Fields		3.15	3.15	-	0.00	(3.15)	3.15	-	0.00	(3.15)
Reserve Contribution		6.81	6.81	-	6.81	-	6.81	-	6.81	-
CDO Reimbursement		1.92	1.92	-	1.92	-	1.92	-	1.92	-
Sewer Total		49.47	49.47	-	46.32	(3.15)	49.47	-	46.32	(3.15)
Solid Waste (avg. 64 Gallon Container)		20.30	20.30	-	20.30	-	20.30	-	20.30	-
Security Tax (Maximum Tax Ceiling \$6.00)		6.24	6.24	-	6.24	-	6.24	-	6.24	-
Drainage Tax (Maximum Tax Ceiling \$2.92)		3.10	3.10	-	3.10	-	3.10	-	3.10	-
		\$124.15	\$128.49	4.34	\$125.34	1.19	\$129.74	5.59	\$126.59	2.44
				3.50%		0.96%		4.50%		1.97%

* Assumes that the District is successful in obtaining the Master Reclamation Permit, which eliminates the need to continue the collection of Sewer debt service prefunding
 This is the ultimate goal of the District, however, it will not be known until late 2014 if we are successful.

MEMORANDUM

Date: November 7, 2013
To: Board of Directors
From: Finance Committee Staff
Subject: Approve Transfers to Reserve Funds

RECOMMENDED ACTION

Approve the transfer of \$50,000 of Working Capital to Capital Replacement Reserves for the Drainage Fund and the Security Fund. And approve the transfer of \$38,380 of Working Capital to Admin Replacement Reserves allocated by fund as indicated:

	WATER	SEWER	DRAINAGE	SOLID WASTE	SECURITY
Recommended Reserve Transfer			\$ 50,000		\$50,000
Recommended Admin Reserve (by fund)	\$ 14,930	\$ 11,399	\$ 2,341	\$ 1,919	\$7,791

BACKGROUND

Periodically, every one (1) to two (2) years, the District reviews the amount of working capital on hand to determine if there is available undesignated cash to be transferred into District reserves. District Policy 2012-07, District Operating Fund and Reserve Fund Policy, specifies that the target balance for the District Operating Fund is to be a minimum of six (6) months of cash to fund District expenditures. Government Code 53646(b)(3), which requires the District to have sufficient cash flow to meet the next six (6) months of budgeted expenditures, allows the next six (6) months of projected cash revenues to be included as a source of cash flow to meet this requirement.

The chart below shows the analysis of the level of working capital as of June 30, 2013. As the working capital coverage in Water, Sewer and Solid Waste ranges from 1.9 months to 3.3 months, it is recommended that no transfer of undesignated funds be made to those funds reserve accounts. Drainage has working capital coverage of 6.6, which means that cash and accounts receivable as of June 30, 2013 will cover 6.6 months of expenditures. Security has working capital coverage of 4.9 months. Staff feels that maintaining the working capital coverage to 3 to 4 months in each fund is prudent in maintaining adequate cash flow to cover District expenses. Therefore, staff is recommending that \$50,000 be transferred to reserves in both the Drainage and Security funds (after the transfer, the working capital coverage for Drainage is 3.3 and Security is 4.4). In addition, staff is recommending that the cost savings of \$38,300 achieved in the Administration Department be transferred into Admin Reserves by fund for future Administration Capital Replacement projects.

	WATER	SEWER	DRAINAGE	SOLID WASTE	SECURITY
Cash & Investments	\$ 262,142	\$ 265,458	\$ 81,347	\$ 206,764	\$353,161
AR	\$ 84,361	\$ 220,550	\$ 32,010	\$ 66,004	\$210,971
Subtotal Current Cash	\$ 546,503	\$ 486,008	\$ 113,357	\$ 272,768	\$564,132
Current Liabilities	\$(192,979)	\$(126,920)	\$ (8,848)	\$ (99,488)	\$(32,821)
OPEB	\$ (15,175)	\$ (10,321)	\$ (1,901)	\$ (464)	\$(14,452)
Other Liabilities	\$ (41,550)	\$ (5,582)	\$ (1,146)	\$ (940)	\$ (6,047)
Subtotal Liabilities	\$(249,704)	\$(142,823)	\$ (11,895)	\$(100,892)	\$(53,320)
Working Capital before Admin Reserves	\$ 296,799	\$ 343,185	\$ 101,462	\$ 171,876	\$ 510,812
	38.9%	29.7%	6.1%	5.0%	20.3%
Admin Cost Savings	\$ (14,930)	\$ (11,399)	\$ (2,341)	\$ (1,919)	\$ (7,791)
Working Capital after Admin Reserves	\$ 281,869	\$ 331,786	\$ 99,121	\$ 169,957	\$ 503,021
2013-14 Avg Monthly Budget Expenditures	\$ 149,928	\$104,492	\$ 15,041	\$ 51,792	\$ 102,474
Working Capital Coverage (months) =	1.9	3.2	6.6	3.3	4.9

The Finance Committee recommends approval.

MEMORANDUM

Date: November 14, 2013
To: Board of Directors
From: Edward R. Crouse, General Manager
Subject: Adopt Resolution 2013-04 Prequalification of Bidders on Public Works Contracts;
Provide Direction Concerning Prequalification on Water Treatment Plant Expansion

RECOMMENDED ACTION

1. Adopt Resolution 2013-04, authorizing prequalification of prospective bidders for public works projects.
2. Should the Resolution be adopted, staff further requests that the Board provide direction as to whether to use the prequalification procedures on the proposed Water Treatment Plant Expansion Project, at the discretion of the District General Manager in consultation with Roebbelen CMS and legal counsel.

BACKGROUND

California Public Contract Code section 20682 requires competitive bidding by the District for public works projects exceeding a cost of \$25,000. California Public Contract Code section 20101 authorizes the District to adopt a system of prequalification of bidders on particular public works projects. With such a system in place, only those bidders prequalified for a project would be eligible to bid on it.

Attached is a proposed resolution authorizing prequalification of bidders on a project-by project basis. Also attached is the State of California, Department of Industrial Relations model forms for prequalification of bidders. These model forms would serve as the basis for prequalification of bidders should the Board adopt the proposed resolution.

If the Board adopts the proposed resolution, staff requests that the Board provide direction as to whether to use the prequalification procedures on the proposed water treatment plant expansion for any or all of the trades to be bid. For instance, the Board could direct that specific trades be subject to prequalification, such as mechanical and electrical trades, and/or may direct that other trades be subject to a prequalification process. The Board could also direct that trades be subject to prequalification or not, at the discretion of the District General Manager in consultation with Roebbelen CMS and legal counsel.

RESOLUTION NO. 2013-04

A RESOLUTION OF THE BOARD OF DIRECTORS OF THE RANCHO MURIETA COMMUNITY SERVICES DISTRICT AUTHORIZING PREQUALIFICATION OF PROSPECTIVE BIDDERS FOR PUBLIC WORKS PROJECTS

WHEREAS, Public Contract Code section 20101 authorizes public agencies to establish a system for prequalification of prospective bidders on public works projects, which shall include a process to dispute a proposed prequalification rating;

WHEREAS, the District now seeks to establish a prequalification policy and system to be used on District public works projects, as deemed appropriate on a project-by-project basis.

NOW, THEREFORE, BE IT RESOLVED by the Board of Directors of the Rancho Murieta Community Services District that that the District hereby adopts the bidder prequalification system set forth at Exhibit A, attached hereto and incorporated herein by reference, to be used by the District on any public works project for which the District Board of Directors finds prequalification appropriate.

PASSED AND ADOPTED by the Board of Directors of the Rancho Murieta Community Services District at their regular meeting held on this 20th day of November 2013 by the following roll call vote:

Ayes:
Noes:
Absent:
Abstain:

Gerald Pasek, President of the Board
Rancho Murieta Community Services District

[seal]

Attest:

Suzanne Lindenfeld, District Secretary
Rancho Murieta Community Services District

EXHIBIT A

Prequalification of Bidders

A. Purpose.

This public works bidder prequalification policy is adopted pursuant to Section 20101 of the California Public Contract Code, which authorizes the District to establish a system for prequalification of prospective bidders on public works projects.

B. Prequalification of Bidders.

1. The District hereby establishes a system for prequalification of prospective bidders for public works projects. The District may use the prequalification system identified in this section for any District public works project, as determined to be appropriate by the District Board of Directors.
2. As to any prequalification process for any public works project to which this policy is applied, the District shall apply a uniform system of rating bidders for each project based on: a) the requirements of Section 20101 of the California Public Contract Code, and b) the model guidelines and standardized questionnaire created by the State of California Department of Industrial Relations, as may be modified at the District Board of Director's discretion to address the needs of the particular project, or projects, to which they are to be applied.
3. If prequalification of prospective bidders is required by the District for any particular project, the District Board of Directors, with input from the District General Manager or his/her designee, shall determine which bidders are qualified to bid on that project based upon the uniform system of rating bidders. If the District Board of Directors determines any bidder is not qualified to bid a project, the District General Manager shall mail to the bidder(s) written notice that includes the basis for the determination and an identification of any supporting evidence therefore.
4. A copy of all prequalification determinations shall be filed with the District Secretary at least ten (10) days prior to the scheduled bid opening for the particular project.

C. Dispute of Prequalification.

1. Any person or entity aggrieved by a determination made by the District pursuant to this policy ("aggrieved party") may dispute the determination of the District only by complying with the requirements set forth in this section. Without a timely notice of prequalification dispute, as set forth herein, the aggrieved party waives any and all rights to challenge the District's prequalification determinations, whether by administrative process, judicial process, or any other legal process or proceeding.

2. In order to dispute a prequalification determination made by the District, the aggrieved party shall submit a written notice of prequalification dispute to the District Secretary, along with a complete written description of all factual and legal bases for the dispute, no later than ten (10) days after the District General Manager has mailed written notice of the determination made by the District.

3. If the aggrieved party provides a proper and timely notice of prequalification dispute, as provided above, the District Board of Directors shall hear the prequalification dispute. The hearing shall be conducted so that it is concluded no later than five (5) days prior to the last date for the receipt of bids on the project or thirty (30) days following District's receipt of the notice of prequalification dispute, whichever is sooner. The hearing shall be a informal in nature, and the formal rules of evidence and procedure applicable to a civil actions shall not apply.

4. At the hearing, the aggrieved party shall be provided an opportunity to be represented by legal counsel and to present or rebut any evidence bearing upon the issue of the bidders' qualification and/or those in the notice of prequalification dispute. Each party shall bear his, her, its, or their own attorneys' fees, regardless of the outcome of the prequalification dispute.

5. The District Board of Directors shall consider the evidence presented during the hearing and make a determination on the dispute in a reasonably timely fashion. The decision may be oral or in writing, at the District Board of Director's discretion. Failure of the Board of Directors to render a decision by the last date for the receipt of bids on the project shall be deemed a denial of relief to the aggrieved party, and the initial determination(s) shall stand.

6. Any prequalification determinations made by the Board of Directors pursuant to this section shall be final, and there shall be no further right to any administrative appeal with the District.

**PRE-QUALIFICATION OF CONTRACTORS
SEEKING TO BID ON PUBLIC WORKS
PROJECTS:**

*The 1999 State Legislation and the
Model Forms Created by the
Department of Industrial Relations*



TABLE OF CONTENTS

	PAGE
INTRODUCTION AND OVERVIEW OF THE 1999 LAW AND ITS APPLICATION	1
I. Important Provisions Of The 1999 Law.....	2
II. Role of the Department of Industrial Relations.....	2
III. An Overview Of The Documents In This Package.....	3
IV. Appeal Procedure	4
V. Application Of The Public Records Act.....	5
VI. What Are The Law’s Provisions Regarding Prequalification Of Subcontractors.....	5
MODEL PRE-QUALIFICATION QUESTIONNAIRE.....	6
Contact Information	7
Part I: Essential Requirements for Qualification	8
Part II: Organization, History, Organizational Performance, Compliance with Civil and Criminal Laws	10
A. Current Organization And Structure Of The Business	10
B. History of The Business And Organizational Performance	11
C. Compliance With Occupational Safety And Health Laws And With Other Labor Legislation Safety	16
Part III. Recent Construction Projects Completed	19
A LIST OF THE SCORABLE QUESTIONS AND THE SCORING INSTRUCTIONS	21
MODEL INTERVIEW QUESTIONS	35
INSTRUCTIONS FOR PUBLIC AGENCIES RE: INTERVIEW QUESTIONS	38
REQUEST FOR PRE-QUALIFICATION OF BIDDERS COMMENCING WITH FORTHCOMING PUBLIC WORK BID.....	41
ANNOUNCEMENT OF PRE-QUALIFICATION PROCEDURES AND OPEN DATES FOR ANNUAL PRE-QUALIFICATION	45
SOURCES FOR VERIFICATION OF INFORMATION GIVEN BY CONTRACTORS.....	49

**INTRODUCTION AND
OVERVIEW OF THE 1999 LAW
AND ITS APPLICATION**

I. IMPORTANT PROVISIONS OF THE 1999 LAW

In 1999, the Legislature enacted a law that allows many public agencies to require licensed contractors that wish to bid for public works jobs to “pre-qualify” for the right to bid on a specific public works project, or on public works project undertaken by a public agency during a specified period of time. Public Contract Code section 20101 has the relevant provisions; it was enacted as part of Assembly Bill 574.

The law applies to all cities, counties, and special districts but does not apply to K-12 school districts (which have similar authority to create pre-qualification procedures, described in Public Contract Code section 20111.5, which was enacted in 1997).¹

The law does not require any public agency to adopt a pre-qualification system. Instead, it authorizes every public agency to adopt a pre-qualification system, and describes certain requirements that must be met (described below), if a public agency chooses to adopt such a system.

In fact, the 1999 law allows a public agency to establish two different kinds of pre-qualification procedures for public works projects. The law allows a public agency to establish a pre-qualification procedure linked to a single project (Section 20101[d]). Or, the public agency may adopt a procedure by which a contractor may qualify to bid on projects which are put out for bid by that agency for a period of one year after the date of initial pre-qualification. (Section 20101[c]).

The law requires every public agency that creates either kind of pre-qualification procedure to:

(1) use a “standardized questionnaire and financial statement in a form specified by the public entity”(Section 20101[a]);

(2) adopt and apply a uniform system of rating bidders on objective criteria, on the basis of the completed questionnaires and financial statements (Section 20101[b]);

(3) create an appeal procedure, by which a contractor that is denied pre-qualification may seek a reversal of that determination. (Section 20101[d]).

II. ROLE OF THE DEPARTMENT OF INDUSTRIAL RELATIONS

AB 574 required the Department of Industrial Relations (DIR) to “develop model guidelines for rating bidders, and draft the standardized questionnaire.” It required DIR to “consult with affected public agencies, cities and counties, the construction industry, the surety industry, and other interested parties.”

¹ Community College Districts also have specific authority to carry out prequalification procedures, in Public Contract Code section 20651.5, enacted in 1998. Community College Districts may also be covered by AB 574, since they are not specifically exempted.

From January through October 2000, DIR held a series of meetings in Sacramento with representatives of public agencies and other interested parties. Each meeting was attended by more than 25 representatives of interested parties. All told, more than 60 people participated in at least one such meeting, and most representatives participated in more than one. Contractors, public agencies both large and small, and associations of each were well represented throughout the series of meetings. DIR's initial draft of a questionnaire was revised after each meeting, and each revised draft was discussed at the next meeting, leading to additional revisions. Eventually, there was widespread consensus that the model questionnaire provided in this package offers a system of rating bidders based on objective criteria, and a useful and appropriate series of questions.

In addition, DIR, in compliance with the 1999 legislation, created model guidelines for rating bidders. The model rating system also is included in this package.

III. AN OVERVIEW OF THE DOCUMENTS IN THIS PACKAGE

Included in this package are:

1. A model questionnaire to be sent to contractors. The questionnaire includes spaces for answers to be provided by the contractors, with the forms to be returned to the public agency.² As required by the legislation, the information provided to the public agency by the contractors, other than the names, addresses and contractor license numbers of the contractors applying – is to be kept confidential
2. A model scoring system, for rating the answers given by the contractors and by the references. Note: the documents provided here by DIR are designed to collect the information that a public agency will need to carry out a pre-qualification procedure, and the DIR has proposed a rating system. Each public agency, however, is free to devise its own “uniform system of rating prospective bidders . . . based on objective criteria.” That is, each public agency may determine its own scoring system and its own passing scores for different portions of the questionnaire and for the interviews.
3. A model series of questions to be used by representatives of the public agency when interviewing persons who are identified by contractors as their “references” – owners of projects that have been completed by each contractor in the recent past.
4. DIR's suggestions for procedures to be used for conducting the reference interviews.
5. Two alternative forms: model announcements of pre-qualification procedures. Each is a summary and explanation of the pre-qualification procedure, prepared primarily for licensed contractors, although available for the general public as well. There are two slightly different versions of this document: one explains the pre-qualification procedure linked to a single project,³

² The documents included in this package can be found at the Department of Industrial Relations web site, www.dir.ca.gov. Click on “Data bases.”

³ The explanation included in this document assumes that the prequalification procedure is taking place after the RFP or project announcement is published. A public agency may choose, instead, to have the prequalification

while the other explains the procedure of pre-qualification valid for a year and for more than one project.

6. A list of sources of information that may be used by a public agency to verify the accuracy of many of the answers given by the contractors to the questions on the questionnaire.⁴

IV. APPEAL PROCEDURE

Section 20101(d) requires every public agency that requires prospective bidders to prequalify pursuant to this law to establish “a process that will allow prospective bidders to dispute their proposed prequalification rating prior to the closing time for receipt of bids.” The appeal process must include written notification by the public agency of the basis for the prospective bidder’s disqualification “and any supporting evidence that has been received from others or adduced as a result of an investigation by the public entity.” (section 20101[d][1]). The prospective bidder must be given an opportunity to rebut any evidence used as a basis for disqualification and to present evidence to the public entity as to why the prospective bidder should be found qualified.” (section 20101[d][2]). The law does not describe the appeal procedure in any additional detail; each public agency is free to adopt its own procedures, as long as the statutory requirements are met. As an example, while Part I of the model questionnaire includes nine “Essential Requirements for Qualification,” a public agency may choose to allow contractors to appeal a disqualification based solely on an answer to a question in Part I.

DIR has devised two different schedules for appeal procedures. One schedule would be used in a system for prequalification for a single project. The sequence of steps in this appeal procedure are scheduled to allow for an appeal decision at least four business days prior to the submission for bids for the single project. The other schedule for an appeal is applicable to a system in which prospective bidders seek prequalification valid for one year, without a link to the bidding on a specific project. These two appeal sequences are described in the explanation to contractors (the two documents referred to in paragraph 5, above).

Each public agency should be certain that it distributes to licensed contractors only the description that is appropriate for the prequalification procedures that are in use.

There are a number of laws and court decisions that affect the nature of an appeal hearing provided by a public agency. Each public agency should consult its own attorneys for advice in this area.

procedure start and end prior to the solicitation of bids for the specific project. If that is the case, the public agency would have to modify the document offered here to explain the sequence of events.

⁴ **A CAUTIONARY NOTE:** The information that will be given to public agencies by contractors seeking pre-qualification is provided under oath, with the understanding that the intentional providing of false information is, in itself, grounds for disqualification. We expect that the information given should be and will be accepted at face value in most instances. Our list of sources of information available to the public is provided for use in the few instances in which a public agency reviewing the answers given in a questionnaire has specific reason to believe that one or more answers should be verified in this manner.

V. APPLICATION OF THE PUBLIC RECORDS ACT

AB 574 provides that “The questionnaires and financial statements shall not be public records and shall not be open to public inspection; however, records of the names of contractors applying for prequalification status shall be public records subject to disclosure” under the Public Records Act. (Section 20101[a]). The model questionnaire forms provided by DIR indicate that the cover page of each questionnaire is a public record, and that all other pages of the questionnaire are not public records.

VI. WHAT ARE THE LAW’S PROVISIONS REGARDING PREQUALIFICATION OF SUBCONTRACTORS?

Public agencies are not required to pre-qualify sub-contractors, nor are public agencies prohibited from doing so. Section 20101(f) says:

Nothing in this section shall preclude the awarding agency from prequalifying or disqualifying a subcontractor. The disqualification by an awarding agency does not disqualify an otherwise prequalified [general] contractor.

MODEL PRE-QUALIFICATION QUESTIONNAIRE

CONTACT INFORMATION

Firm Name: _____ Check One: Corporation
(as it appears on license) Partnership
 Sole Prop.

Contact Person: _____

Address: _____

Phone: _____ Fax: _____

If firm is a sole proprietor or partnership:

Owner(s) of Company _____

Contractor's License Number(s):

PART I. ESSENTIAL REQUIREMENTS FOR QUALIFICATION

Contractor will be immediately disqualified if the answer to any of questions 1 through 5 is “no.”⁵

Contractor will be immediately disqualified if the answer to any of questions 6, 7, 8 or 9 is “yes.”⁶ If the answer to question 8 is “yes,” and if debarment would be the sole reason for denial of pre-qualification, any pre-qualification issued will exclude the debarment period.

1. Contractor possesses a valid and current California Contractor’s license for the project or projects for which it intends to submit a bid.
 Yes No
2. Contractor has a liability insurance policy with a policy limit of at least \$1,000,000 per occurrence and \$2,000,000 aggregate.
 Yes No
3. Contractor has current workers’ compensation insurance policy as required by the Labor Code or is legally self-insured pursuant to Labor Code section 3700 et. seq.
 Yes No Contractor is exempt from this requirement, because it has no employees
4. Have you attached your latest copy of a reviewed or audited financial statement with accompanying notes and supplemental information.⁷
 Yes No

NOTE: A financial statement that is not either reviewed or audited is not acceptable. A letter verifying availability of a line of credit may also be attached; however, it will be considered as supplemental information only, and is not a substitute for the required financial statement.

5. Have you attached a notarized statement from an admitted surety insurer (approved by the California Department of Insurance) and authorized to issue bonds in the State of California, which states: (a) that your current bonding capacity is sufficient for the project for which

⁵ A “no” answer to Question 4 will not be disqualifying if the contractor is exempt from complying with Question 4, for reasons explained in footnote 7.

⁶ A contractor disqualified solely because of a “Yes” answer given to question 6, 7, or 9 may appeal the disqualification and provide an explanation of the relevant circumstances during the appeal procedure.

⁷ Public Contract Code section 20101(e) exempts from this requirement a contractor who has qualified as a small business pursuant to Government Code section 14837(d)(1), if the bid is “no more than 25 per cent of the qualifying amount provided in section 14837(d)(1).” As of January 1, 2001, the qualifying amount is \$10 million, and 25 per cent of that amount, therefore, is \$2.5 million.

you seek pre-qualification if you are seeking pre-qualification for a single project; or (if you are seeking pre-qualification valid for a year) (b) your current available bonding capacity?⁸

Yes No

NOTE: Notarized statement must be from the surety company, not an agent or broker.

6. Has your contractor's license been revoked at any time in the last five years?

Yes No

7. Has a surety firm completed a contract on your behalf, or paid for completion because your firm was default terminated by the project owner within the last five (5) years?

Yes No

8. At the time of submitting this pre-qualification form, is your firm ineligible to bid on or be awarded a public works contract, or perform as a subcontractor on a public works contract, pursuant to either Labor Code section 1777.1 or Labor Code section 1777.7?

Yes No

If the answer is "Yes," state the beginning and ending dates of the period of debarment:

9. At any time during the last five years, has your firm, or any of its owners or officers been convicted of a crime involving the awarding of a contract of a government construction project, or the bidding or performance of a government contract?

Yes No

⁸ An additional notarized statement from the surety may be requested by *Public Entity* at the time of submission of a bid, if this pre-qualification package is submitted more than 60 days prior to submission of the bid.

PART II. ORGANIZATION, HISTORY, ORGANIZATIONAL PERFORMANCE, COMPLIANCE WITH CIVIL AND CRIMINAL LAWS

A. Current Organization and Structure of the Business

For Firms That Are Corporations:

- 1a. Date incorporated : _____
- 1b. Under the laws of what state: _____
- 1c. Provide all the following information for each person who is either (a) an officer of the corporation (president, vice president, secretary, treasurer), or (b) the owner of at least ten per cent of the corporation’s stock.

Name	Position	Years with Co.	% Ownership	Social Security #

- 1d. Identify every construction firm that any person listed above has been associated with (as owner, general partner, limited partner or officer) at any time during the last five years.
NOTE: For this question, “owner” and “partner” refer to ownership of ten per cent or more of the business, or 10 per cent or more of its stock, if the business is a corporation.

Person’s Name	Construction Firm	Dates of Person’s Participation with Firm

For Firms That Are Partnerships:

- 1a. Date of formation: _____
- 1b. Under the laws of what state: _____
- 1c. Provide all the following information for each partner who owns 10 per cent or more of the firm.

Name	Position	Years with Co.	% Ownership	Social Security #

- 1d. Identify every construction company that any partner has been associated with (as owner, general partner, limited partner or officer) at any time during the last five years.

NOTE: For this question, “owner” and “partner” refer to ownership of ten per cent or more of the business, or ten per cent or more of its stock, if the business is a corporation.

Person’s Name	Construction Company	Dates of Person’s Participation with Company

For Firms That Are Sole Proprietorships:

- 1a. Date of commencement of business. _____
 1b. Social security number of company owner. _____
 1c. Identify every construction firm that the business owner has been associated with (as owner, general partner, limited partner or officer) at any time during the last five years.

NOTE: For this question, “owner” and “partner” refer to ownership of ten per cent or more of the business, or ten per cent or more of its stock, if the business is a corporation.

Person’s Name	Construction Company	Dates of Person’s Participation with Company

For Firms That Intend to Make a Bid as Part of a Joint Venture:

- 1a. Date of commencement of joint venture. _____
 1b. Provide all of the following information for each firm that is a member of the joint venture that expects to bid on one or more projects:

Name of firm	% Ownership of Joint Venture

B. History of the Business and Organizational Performance

2. Has there been any change in ownership of the firm at any time during the last three years?
NOTE: A corporation whose shares are publicly traded is not required to answer this question.

Yes No

If "yes," explain on a separate signed page.

3. Is the firm a subsidiary, parent, holding company or affiliate of another construction firm?
NOTE: Include information about other firms if one firm owns 50 per cent or more of another, or if an owner, partner, or officer of your firm holds a similar position in another firm.

Yes No

If "yes," explain on a separate signed page.

4. Are any corporate officers, partners or owners connected to any other construction firms.
NOTE: Include information about other firms if an owner, partner, or officer of your firm holds a similar position in another firm.

Yes No

If "yes," explain on a separate signed page.

5. State your firm's gross revenues for each of the last three years:

6. How many years has your organization been in business in California as a contractor under your present business name and license number? _____ years

7. Is your firm currently the debtor in a bankruptcy case?

Yes No

If "yes," please attach a copy of the bankruptcy petition, showing the case number, and the date on which the petition was filed.

8. Was your firm in bankruptcy at any time during the last five years? (This question refers only to a bankruptcy action that was not described in answer to question 7, above)

Yes No

If "yes," please attach a copy of the bankruptcy petition, showing the case number and the date on which the petition was filed, and a copy of the Bankruptcy Court's discharge order, or of any other document that ended the case, if no discharge order was issued.

Licenses

9. List all California construction license numbers, classifications and expiration dates of the California contractor licenses held by your firm:

10. If any of your firm's license(s) are held in the name of a corporation or partnership, list below the names of the qualifying individual(s) listed on the CSLB records who meet(s) the experience and examination requirements for each license.

11. Has your firm changed names or license number in the past five years?
 Yes No
If "yes," explain on a separate signed page, including the reason for the change.
12. Has any owner, partner or (for corporations:) officer of your firm operated a construction firm under any other name in the last five years?
 Yes No
If "yes," explain on a separate signed page, including the reason for the change.
13. Has any CSLB license held by your firm or its Responsible Managing Employee (RME) or Responsible Managing Officer (RMO) been suspended within the last five years?
 Yes No
If "yes," please explain on a separate signed sheet.

Disputes

14. At any time in the last five years has your firm been assessed and paid liquidated damages after completion of a project under a construction contract with either a public or private owner?
 Yes No
If yes, explain on a separate signed page, identifying all such projects by owner, owner's address, the date of completion of the project, amount of liquidated damages assessed and all other information necessary to fully explain the assessment of liquidated damages.
15. In the last five years has your firm, or any firm with which any of your company's owners, officers or partners was associated, been debarred, disqualified, removed or otherwise prevented from bidding on, or completing, any government agency or public works project for any reason?
NOTE: "Associated with" refers to another construction firm in which an owner, partner or officer of your firm held a similar position, and which is listed in response to question 1c or 1d on this form.
 Yes No
If "yes," explain on a separate signed page. State whether the firm involved was the firm applying for pre-qualification here or another firm. Identify by name of the company, the name of the person within your firm who was associated with that company, the year of the event, the owner of the project, the project and the basis for the action.
16. In the last five years has your firm been denied an award of a public works contract based on a finding by a public agency that your company was not a responsible bidder?

Yes No

If “yes,” explain on a separate signed page. Identify the year of the event, the owner, the project and the basis for the finding by the public agency.

* * * * *

NOTE: The following two questions refer only to disputes between your firm and the owner of a project. You need not include information about disputes between your firm and a supplier, another contractor, or subcontractor. You need not include information about “pass-through” disputes in which the actual dispute is between a sub-contractor and a project owner. Also, you may omit reference to all disputes about amounts of less than \$50,000.

17. In the past five years has any claim **against** your firm concerning your firm’s work on a construction project been **filed in court or arbitration?**

Yes No

If “yes,” on separate signed sheets of paper identify the claim(s) by providing the project name, date of the claim, name of the claimant, a brief description of the nature of the claim, the court in which the case was filed and a brief description of the status of the claim (pending or, if resolved, a brief description of the resolution).

18. In the past five years has your firm made any claim against a project owner concerning work on a project or payment for a contract and **filed that claim in court or arbitration?**

Yes No

If “yes,” on separate signed sheets of paper identify the claim by providing the project name, date of the claim, name of the entity (or entities) against whom the claim was filed, a brief description of the nature of the claim, the court in which the case was filed and a brief description of the status of the claim (pending, or if resolved, a brief description of the resolution).

* * * * *

19. At any time during the past five years, has any surety company made any payments on your firm’s behalf as a result of a default, to satisfy any claims made against a performance or payment bond issued on your firm’s behalf, in connection with a construction project, either public or private?

Yes No

If “yes,” explain on a separate signed page the amount of each such claim, the name and telephone number of the claimant, the date of the claim, the grounds for the claim, the present status of the claim, the date of resolution of such claim if resolved, the method by which such was resolved if resolved, the nature of the resolution and the amount, if any, at which the claim was resolved.

20. In the last five years has any insurance carrier, for any form of insurance, refused to renew the insurance policy for your firm?

Yes No

If “yes,” explain on a separate signed page. Name the insurance carrier, the form of insurance and the year of the refusal.

Criminal Matters and Related Civil Suits

21. Has your firm or any of its owners, officers or partners ever been found liable in a civil suit or found guilty in a criminal action for making any false claim or material misrepresentation to any public agency or entity?

Yes No

If “yes,” explain on a separate signed page, including identifying who was involved, the name of the public agency, the date of the investigation and the grounds for the finding.

22. Has your firm or any of its owners, officers or partners ever been convicted of a crime involving any federal, state, or local law related to construction?

Yes No

If “yes,” explain on a separate signed page, including identifying who was involved, the name of the public agency, the date of the conviction and the grounds for the conviction.

23. Has your firm or any of its owners, officers or partners ever been convicted of a federal or state crime of fraud, theft, or any other act of dishonesty?

Yes No

If “yes,” identify on a separate signed page the person or persons convicted, the court (the county if a state court, the district or location of the federal court), the year and the criminal conduct.

Bonding

24. Bonding capacity: Provide documentation from your surety identifying the following:

Name of bonding company/surety: _____

Name of surety agent, address and telephone number:

25. If your firm was required to pay a premium of more than one per cent for a performance and payment bond on any project(s) on which your firm worked at any time during the last three years, state the percentage that your firm was required to pay. You may provide an explanation for a percentage rate higher than one per cent, if you wish to do so.

26. List all other sureties (name and full address) that have written bonds for your firm during the last five years, including the dates during which each wrote the bonds:

27. During the last five years, has your firm ever been denied bond coverage by a surety company, or has there ever been a period of time when your firm had no surety bond in place during a public construction project when one was required?

Yes No

If yes, provide details on a separate signed sheet indicating the date when your firm was denied coverage and the name of the company or companies which denied coverage; and the period during which you had no surety bond in place.

C. Compliance with Occupational Safety and Health Laws and with Other Labor Legislation Safety

28. Has CAL OSHA cited and assessed penalties against your firm for any “serious,” “willful” or “repeat” violations of its safety or health regulations in the past five years?

NOTE: If you have filed an appeal of a citation, and the Occupational Safety and Health Appeals Board has not yet ruled on your appeal, you need not include information about it.

Yes No

If “yes,” attached a separate signed page describing the citations, including information about the dates of the citations, the nature of the violation, the project on which the citation(s) was or were issued, the amount of penalty paid, if any. If the citation was appealed to the Occupational Safety and Health Appeals Board and a decision has been issued, state the case number and the date of the decision.

29. Has the federal Occupational Safety and Health Administration cited and assessed penalties against your firm in the past five years?

NOTE: If you have filed an appeal of a citation and the Appeals Board has not yet ruled on your appeal, or if there is a court appeal pending, you need not include information about the citation.

Yes No

If “yes,” attach a separate signed page describing each citation.

30. Has the EPA or any Air Quality Management District or any Regional Water Quality Control Board cited and assessed penalties against either your firm or the owner of a project on which your firm was the contractor, in the past five years?

NOTE: If you have filed an appeal of a citation and the Appeals Board has not yet ruled on your appeal, or if there is a court appeal pending, you need not include information about the citation.

Yes No

If “yes,” attach a separate signed page describing each citation.

31. How often do you require documented safety meetings to be held for construction employees and field supervisors during the course of a project?

32. List your firm’s Experience Modification Rate (EMR) (California workers’ compensation insurance) for each of the past three premium years:
NOTE: An Experience Modification Rate is issued to your firm annually by your workers’ compensation insurance carrier.

Current year: _____

Previous year: _____

Year prior to previous year: _____

If your EMR for any of these three years is or was 1.00 or higher you may, if you wish, attach a letter of explanation.

33. Within the last five years has there ever been a period when your firm had employees but was without workers’ compensation insurance or state-approved self-insurance?

Yes No

If “yes,” please explain the reason for the absence of workers’ compensation insurance on a separate signed page. If “No,” please provide a statement by your current workers’ compensation insurance carrier that verifies periods of workers’ compensation insurance coverage for the last five years. (If your firm has been in the construction business for less than five years, provide a statement by your workers’ compensation insurance carrier verifying continuous workers’ compensation insurance coverage for the period that your firm has been in the construction business.)

Prevailing Wage and Apprenticeship Compliance Record

34. Has there been more than one occasion during the last five years in which your firm was required to pay either back wages or penalties for your own firm’s failure to comply with the **state’s** prevailing wage laws?

NOTE: This question refers only to your own firm’s violation of prevailing wage laws, not to violations of the prevailing wage laws by a subcontractor.

Yes No

If "yes," attach a separate signed page or pages, describing the nature of each violation, identifying the name of the project, the date of its completion, the public agency for which it was constructed; the number of employees who were initially underpaid and the amount of back wages and penalties that you were required to pay.

35. During the last five years, has there been more than one occasion in which your own firm has been penalized or required to pay back wages for failure to comply with the **federal Davis-Bacon** prevailing wage requirements?

Yes No

If "yes," attach a separate signed page or pages describing the nature of the violation, identifying the name of the project, the date of its completion, the public agency for which it was constructed; the number of employees who were initially underpaid, the amount of back wages you were required to pay along with the amount of any penalty paid.

36. Provide the **name, address and telephone number** of the apprenticeship program (approved by the California Apprenticeship Council) from whom you intend to request the dispatch of apprentices to your company for use on any public work project for which you are awarded a contract by *[Public Entity]*.

37. If your firm operates its own State-approved apprenticeship program:

- (a) Identify the craft or crafts in which your firm provided apprenticeship training in the past year.
- (b) State the year in which each such apprenticeship program was approved, and attach evidence of the most recent California Apprenticeship Council approval(s) of your apprenticeship program(s).
- (c) State the number of individuals who were employed by your firm as apprentices at any time during the past three years in each apprenticeship and the number of persons who, during the past three years, completed apprenticeships in each craft while employed by your firm.

38. At any time during the last five years, has your firm been found to have violated any provision of California apprenticeship laws or regulations, or the laws pertaining to use of apprentices on public works?

NOTE: You may omit reference to any incident that occurred prior to January 1, 1998, if the violation was by a subcontractor and your firm, as general contractor on a project, had no knowledge of the subcontractor's violation at the time they occurred.

Yes No

If "yes," provide the date(s) of such findings, and attach copies of the Department's final decision(s).

PART III. RECENT CONSTRUCTION PROJECTS COMPLETED

39. Contractor shall provide information about its six most recently completed public works projects and its three largest completed private projects within the last three years.⁹ Names and references must be current and verifiable. Use separate sheets of paper that contain all of the following information:

Project Name: _____

Location: _____

Owner: _____

Owner Contact (name and current phone number):

Architect or Engineer: _____

Architect or Engineer Contact (name and current phone number):

Construction Manager (name and current phone number):

⁹ If you wish, you may, using the same format, also provide information about other projects that you have completed that are similar to the project(s) for which you expect to bid.

Description of Project, Scope of Work Performed:

Total Value of Construction (including change orders): _____

Original Scheduled Completion Date: _____

Time Extensions Granted (number of days): _____

Actual Date of Completion: _____

* * * * *

I, the undersigned, certify and declare that I have read all the foregoing answers to this prequalification questionnaire and know their contents. The matters stated in the questionnaire answers are true of my own knowledge and belief, except as to those matters stated on information and belief, and as to those matters I believe them to be true. I declare under penalty of perjury under the laws of the State of California, that the foregoing is correct.

Dated: _____
(Name)

A LIST OF THE SCORABLE QUESTIONS AND THE SCORING INSTRUCTIONS

A LIST OF THE SCORABLE QUESTIONS AND THE SCORING INSTRUCTIONS

The scorable questions arise in three different areas:

- (I) History of the business and organizational performance;
- (II) Compliance with occupational safety and health laws, workers' compensation and other labor legislation; and
- (III) Completion of recent projects and quality of performance.

The interview questions (interviews by the public agency of project managers on projects completed recently by the contractor) are included in group III. In a pre-qualification procedure for a single project, this last category would also include a scoring of the number of recently completed projects that are similar to the project on which pre-qualification is at issue. However, scoring linked to the similarity of past projects would **probably not be possible or useful** if the public agency as part of a procedure to pre-qualify contractors for an extended period.

Note: Not all questions in the questionnaire are scorable; some questions simply ask for information about the contractor firm's structure, officers and history. This document includes only those questions that are "scorable." The question numbers in this document are the numbers used in the questionnaire. Thus, the questions included here begin with question number 6, and there are a few breaks in the numerical sequence.

The Scores Needed for Prequalification

To prequalify, a contractor would be required to have a passing grade within each of the three large categories referred to above.

For Section I, "History of the business and organizational performance," DIR recommends use of a passing score of **57** on this portion of the questionnaire (of a maximum score of 76 on this portion of the questionnaire).

For Section II, Compliance with occupational safety and health laws, workers' compensation and other labor legislation DIR recommends use of a passing score of **38** on this portion of the questionnaire (of a maximum score of 53 points on this portion of the questionnaire).

Section III, Completion of recent projects and quality of performance, includes a series of interview questions, and may also include questions about recently completed (public or private) construction projects. For the interview questions, DIR recommends that a public agency interview project managers for the owners of two completed projects. DIR recommends a scoring system that would allow a maximum score of 120 points for each interview. For these questions, DIR recommends qualification for a contractor whose score on each of two interviews is 72 points or more; a denial of pre-qualification

for a contractor whose score on either interview is less than 55 points; and an additional interview with another reference if the score resulting from one interview is between 55 points and 72 points.

DIR makes no recommendation about how to score a contractor's answers about recently completed past projects. Because of the wide range of projects that a public agency may be planning, and the similarly wide range in the skills, abilities, and experience that a public agency will consider most important for a pending project, it is impossible to propose a useful model scoring system to apply to the answers given about a contractor's completed projects.

Questions about History of the Business and Organizational Performance

(16 questions)

1. How many years has your organization been in business in California as a contractor under your present business name and license number? _____ years

3 years or more = 2 points

4 years = 3 points 5 years = 4 pts.

6 years or more = 5 points

2. Is your firm currently the debtor in a bankruptcy case?

Yes No

“No” = 3 points“ “Yes” = 0 points

3. Was your firm in bankruptcy any time during the last five years? (This question refers only to a bankruptcy action that was not described in answer to question 7, above).

Yes No

“No” = 3 points“ “Yes” = 0 points

4. Has any CSLB license held by your firm or its Responsible Managing Employee (RME) or Responsible Managing Officer (RMO) been suspended within the last five years?

Yes No

No = 5 points Yes = 0 points

5. At any time in the last five years, has your firm been assessed and paid liquidated damages after completion of a project, under a construction contract with either a public or private owner?
 Yes No

No projects with liquidated damages of more than \$50,000, or one project with liquidated damages = 5 points.

Two projects with liquidated damages of more than \$50,000 = 3 points

Any other answer: no points

6. In the last five years has your firm, or any firm with which any of your company's owners, officers or partners was associated, been debarred, disqualified, removed or otherwise prevented from bidding on, or completing, any government agency or public works project for any reason?

NOTE: "Associated with" refers to another construction firm in which an owner, partner or officer of your firm held a similar position, and which is listed in response to question 1c or 1d on this form.

Yes No

No = 5 points Yes = 0 points

7. In the last five years, has your firm been denied an award of a public works contract based on a finding by a public agency that your company was not a responsible bidder?
 Yes No

No = 5 points Yes = 0 points

* * * * *

NOTE: The following two questions refer only to disputes between your firm and the owner of a project. You need not include information about disputes between your firm and a supplier, another contractor, or subcontractor. You need not include information about "pass-through" disputes in which the actual dispute is between a sub-contractor and a project owner. Also, you may omit reference to all disputes about amounts of less than \$50,000.

8. In the past five years, has any claim **against** your firm concerning your firm's work on a construction project, been **filed in court or arbitration?**

Yes No

If the firm's average gross revenue for the last three years was less than \$50 million, scoring is as follows:

*5 points for either "No" or "Yes" indicating 1 such instance.
3 points for "Yes" indicating 2 such instances.
0 points for "Yes" if more than 2 such instances.*

If your firm's average gross revenue for the last three years was more than \$50 million, scoring is as follows:

*5 points for either "No" or "Yes" indicating 1, 2, or 3 such instances.
3 points for "Yes" indicating either 4 or 5 such instances.
0 points for "Yes" if more than 5 such instances.*

9. In the past five years, has your firm made any claim against a project owner concerning work on a project or payment for a contract, and **filed that claim in court or arbitration?**

Yes No

If your firm's average gross revenues for the last three years was less than \$50 million scoring is as follows:

*5 points for either "No" or "Yes" indicating 1 such instance.
3 points for "Yes" indicating 2 such instances.
0 points for "Yes" if more than 2 such instances.*

If your firm's average gross revenues for the last three years was more than \$50 million, scoring is as follows:

*5 points for either "No" or "Yes" indicating 1, 2, or 3 such instances.
3 points for "Yes" indicating either 4 or 5 such instances.
0 points for "Yes" if more than 5 such instances.*

10. At any time during the past five years, has any surety company made any payments on your firm's behalf as a result of a default, to satisfy any claims made against a performance or payment bond issued on your firm's behalf in connection with a construction project, either public or private?
 Yes No

***5 points for either "No" or "Yes" indicating 1 such claim.
3 points for "Yes" indicating no more than 2 such claims
Subtract five points for "Yes" if more than 2 such claims***

11. In the last five years, has any insurance carrier, for any form of insurance, refused to renew the insurance policy for your firm?
 Yes No

***5 points for either "No" or "Yes" indicating 1 such instance.
3 points for "Yes" indicating 2 such instances.
0 points for "Yes" or if more than 2 such instances.***

12. Has your firm, or any of its owners, officers, or partners ever been found liable in a civil suit, or found guilty in a criminal action, for making any false claim or material misrepresentation to any public agency or entity?
 Yes No

No = 5 points Yes = subtract 5 points

13. Has your firm, or any of its owners, officers or partners ever been convicted of a crime involving any federal, state, or local law related to construction?
 Yes No

No = 5 points Yes = subtract 5 points

14. Has your firm or any of its owners, officers or partners ever been convicted of a federal or state crime of fraud, theft, or any other act of dishonesty?
 Yes No

No = 5 points Yes = subtract 5 points

15. If your firm was required to pay a premium of more than one per cent for a performance and payment bond on any project(s) on which your firm worked at any time during the last three years, state the percentage that your firm was required to pay. You may provide an explanation for a percentage rate higher than one per cent, if you wish to do so.

_____ %

*5 points if the rate is no more than one per cent
3 points if the rate was no higher than 1.10 per cent.
0 points for any other answer.*

16. During the last five years, has your firm ever been denied bond credit by a surety company, or has there ever been a period of time when your firm had no surety bond in place during a public construction project when one was required?

Yes No

No = 5 points Yes = 0 points

**Questions about compliance with safety, workers compensation,
prevailing wage and apprenticeship laws.**

(11 questions)

1. Has CAL OSHA cited and assessed penalties against your firm for any “serious,” “willful” or “repeat” violations of its safety or health regulations in the past five years?

Note: If you have filed an appeal of a citation and the Occupational Safety and Health Appeals Board has not yet ruled on your appeal, you need not include information about it.

Yes No

If the firm’s average gross revenues for the last three years was less than \$50 million, scoring is as follows:

*5 points for either “No” or “Yes” indicating 1 such instance.
3 points for “Yes” indicating 2 such instances.
0 points for “Yes” if more than 2 such instances.*

If the firm’s average gross revenues for the last three years was more than \$50 million, scoring is as follows:

*5 points for either “No” or “Yes” indicating 1, 2, or 3 such instances.
3 points for “Yes” indicating either 4 or 5 such instances.
0 points for “Yes” if more than 5 such instances.*

2. Has the federal Occupational Safety and Health Administration cited and assessed penalties against your firm in the past five years?

Note: If you have filed an appeal of a citation and the appropriate appeals Board has not yet ruled on your appeal, you need not include information about it.

Yes No

If yes, attach a separate signed page describing each citation.

If the firm's average gross revenues for the last three years was less than \$50 million, scoring is as follows:

5 points for either "No" or "Yes" indicating 1 such instance.

3 points for "Yes" indicating 2 such instances.

0 points for "Yes" or if more than 2 such instances.

If the firm's average gross revenues for the last three years was more than \$50 million, scoring is as follows:

5 points for either "No" or "Yes" indicating 1, 2, or 3 such instances.

3 points for "Yes" indicating either 4 or 5 such instances.

0 points for "Yes" if more than 5 such instances.

3. Has the EPA or any Air Quality Management District or any Regional Water Quality Control Board cited and assessed penalties against either your firm or the owner of a project on which your firm was the contractor, in the past five years?

NOTE: If you have filed an appeal of a citation and the Appeals Board has not yet ruled on your appeal, or if there is a court appeal pending, you need not include information about the citation.

Yes No

If the firm's average gross revenues for the last three years was less than \$50 million, scoring is as follows:

5 points for either "No" or "Yes" indicating 1 such instance.

3 points for "Yes" indicating 2 such instances.

0 points for "Yes" or if more than 2 such instances.

If the firm's average gross revenues for the last three years was more than \$50 million, scoring is as follows:

5 points for either "No" or "Yes" indicating 1, 2, or 3 such instances.

3 points for "Yes" indicating either 4 or 5 such instances.

0 points for "Yes" if more than 5 such instances.

4. How often do you require documented safety meetings to be held for construction employees and field supervisors during the course of a project?

***3 points for an answer of once each week or more often.
0 points for any other answer***

5. List your firm's Experience Modification Rate (EMR) (California workers' compensation insurance) for each of the past three premium years:

NOTE: An Experience Modification Rate is issued to your firm annually by your workers' compensation insurance carrier.

Current year: _____

Previous year: _____

Year prior to previous year: _____

If your EMR for any of these three years is or was 1.00 or higher, you may, if you wish, attach a letter of explanation.

NOTE: An Experience Modification Rate is issued to your firm annually by your workers' compensation insurance carrier.

5 points for three-year average EMR of .95 or less

3 points for three-year average of EMR of more than .95 but no more than 1.00

0 points for any other EMR

6. Within the last five years, has there ever been a period when your firm had employees but was without workers' compensation insurance or state-approved self-insurance?

Yes No

5 points for either "No" or "Yes" indicating 1 such instance.

0 points for any other answer.

7. Has there been more than one occasion during the last five years on which your firm was required to pay either back wages or penalties for your own firm's failure to comply with the **state's** prevailing wage laws?

Yes No

NOTE: This question refers only to your own firm's violation of prevailing wage laws, not to violations of the prevailing wage laws by a subcontractor.

If your firm's average gross revenues for the last three years was less than \$50 million, scoring is as follows:

5 points for either "No," or "Yes" indicating either 1 or 2 such instance.

3 points for "Yes" indicating 3 such instances.

0 points for "Yes" and more than 3 such instances.

If your firm's average gross revenues for the last three years was more than \$50 million, scoring is as follows:

5 points for either "No" or "Yes" indicating no more than 4 such instances.

3 points for "Yes" indicating either 5 or 6 such instances.

0 points for "Yes" and more than 6 such instances.

8. During the last five years, has there been more than one occasion on which your own firm has been penalized or required to pay back wages for failure to comply with the **federal** Davis-Bacon prevailing wage requirements?

Yes No

If your firm's average gross revenues for the last three years was less than \$50 million, scoring is as follows:

5 points for either "No," or "Yes" indicating either 1 or 2 such instance.

3 points for "Yes" indicating 3 such instances.

0 points for "Yes" and more than 3 such instances.

If your firm's average gross revenues for the last three years was more than \$50 million, scoring is as follows:

5 points for either "No" or "Yes" indicating no more than 4 such instances.

3 points for "Yes" indicating either 5 or 6 such instances.

0 points for "Yes" and more than 6 such instances.

9. Provide the **name, address and telephone number** of the apprenticeship program sponsor(s) (approved by the California Division of Apprenticeship Standards) that will provide apprentices to your company for use on any public work project for which you are awarded a contract by *[Public Entity]*.
-
-

***5 points if at least one approved apprenticeship program is listed.
0 points for any other answer.***

10. If your firm operates its own State-approved apprenticeship program:
- (a) Identify the craft or crafts in which your firm provided apprenticeship training in the past year.
 - (b) State the year in which each such apprenticeship program was approved, and attach evidence of the most recent California Apprenticeship Council approval(s) of your apprenticeship program(s).
 - (c) State the number of individuals who were employed by your firm as apprentices at any time during the past three years in each apprenticeship and the number of persons who, during the past three years, completed apprenticeships in each craft while employed by your firm.

5 points if one or more persons completed an approved apprenticeship while employed by your firm.

0 points if no persons completed an approved apprenticeship while employer by your firm.

11. At any time during the last five years, has your firm been found to have violated any provision of California apprenticeship laws or regulations, or the laws pertaining to use of apprentices on public works?

NOTE: You may omit reference to any incident that occurred prior to January 1, 1998 if the violation was by a subcontractor and your firm, as general contractor on a project, had no knowledge of the subcontractor's violation at the time they occurred.

Yes No.

If yes, provide the date(s) of such findings, and attach copies of the Department's final decision(s).

If your firm's average gross revenues for the last three years was less than \$50 million, scoring is as follows:

5 points for either "No," or "Yes" indicating either 1 or 2 such instance.

3 points for "Yes" indicating 3 such instances.

0 points for "Yes" and more than 3 such instances.

If your firm's average gross revenues for the last three years was more than \$50 million, scoring is as follows:

5 points for either "No" or "Yes" indicating no more than 4 such instances.

3 points for "Yes" indicating either 5 or 6 such instances.

0 points for "Yes" and more than 6 such instances.

Questions concerning recent construction projects completed:
(one question, plus 11 interview questions)

The following question to be scored only where a public agency is undertaking a pre-qualification procedure valid for a single project only.

1. Contractor shall provide information about its six most recently completed public works projects and its three largest completed private projects within the last three years.¹⁰ Names and references must be current and verifiable. Use separate sheets of paper that contain all of the following information:

Project Name: _____

Location: _____

Owner: _____

Owner Contact (name and current phone number):

Architect or Engineer: _____

Architect or Engineer Contact (name and current phone number):

Construction Manager (name and current phone number):

Description of Project, Scope of Work Performed:

Total Value of Construction (including change orders): _____

Original Scheduled Completion Date: _____

Time Extensions Granted (number of days): _____

Actual Date of Completion: _____

* * * * *

¹⁰ If you wish, you may, using the same format, also provide information about other projects that you have completed that are similar to the project(s) for which you expect to bid.

Scoring of previous projects completed:

For pre-qualification for a single project that may require specific skills and capabilities, public agencies may choose to score contractors for the number of similar projects completed, and the degree of similarity between past projects and the planned project. DIR has not suggested any scoring for this aspect of the pre-qualification process, because of the numerous possible variations in both the type of project to be built and the points of similarity between the pending project and past projects that may be significant to the public agency.

MODEL INTERVIEW QUESTIONS

MODEL INTERVIEW QUESTIONS

The following questions will be used to interview randomly selected contacts from at least two completed projects. [Public Entity] will conduct the interviews. No action on the contractor's part is necessary. These questions are included on the package given to the contractor for information only.

The highest possible score is 120 Points. A score less than 55 points disqualifies a contractor from bidding on projects that are proposed by [Public Entity]. A score of between 56 and 72 indicates *the Public Entity* should conduct an interview of another contact, that is, a manager of another completed project. A score of 72 or higher on each of two interviews is sufficient for pre-qualification.

First, please give a brief description of the project.

1. Are there any outstanding stop notices, liens, or claims by the contractor that are currently unresolved on contracts for which notices of completion were recorded more than 120 days ago? (1 point for each is deducted from overall score; maximum amount to be deducted is 5 points)
2. On a scale of 1-10, with 10 being the best, did the contractor provide adequate personnel? (Max. 10 points)
3. On a scale of 1-10, with 10 being the best, did the contractor provide adequate supervision? (Max. 10 points)
4. On a scale of 1-10, with 10 being the best, was there adequate equipment provided on the job? (Max. 10 points)
5. On a scale of 1-10, with 10 being the best, was the contractor timely in providing reports and other paperwork, including change order paperwork and scheduling updates? (Max. 10 points)
6. On a scale of 1-10, with 10 being the best, did the contractor adhere to the project schedule that your [agency] [business] approved? (Max. 10 points)
7. Was the project completed on time? (10 points if the answer is "Yes").
Or, if the answer is "no," on a scale of 1-10, with 10 being the best, to what extent was the contractor responsible for the delay in completion?
8. On a scale of 1-10, with 10 being the best, rate the contractor on the timely submission of reasonable cost and time estimates to perform change order work. (Max. 10 points)

9. On a scale of 1-10, with 10 being the best, rate the contractor on how well the contractor performed the work after a change order was issued, and how well the contractor integrated the change order work into the existing work. (Max. 10 points).
10. On a scale of 1-10, with 10 being the best, rate how has the contractor been performing in the area of turning in Operation & Maintenance manuals, completing as-built drawings, providing required training and taking care of warranty items? (Max. 10 points)
11. On a scale of 1-10, with 10 being the best, rate the contractor on whether there were an unusually high number of claims, given the nature of the project, or unusual difficulty in resolving them. (Max. 10 points)
12. On a scale of 1-10, with 10 being the highest, rate the contractor with respect to timely payments by the contractor to either subcontractors or suppliers. (If the person being interviewed knows of no such difficulties, the score on this question should be “10.”)
13. On a scale of 1-10, with 10 being the best, how would you rate the quality of the work overall? (Max. 10 points)

**INSTRUCTIONS FOR PUBLIC
AGENCIES RE:
INTERVIEW QUESTIONS**

INSTRUCTIONS FOR PUBLIC AGENCIES

Re: Interview Questions

The following is meant to assist the public agency to conduct the interviews of the managers of projects previously completed (that is, the people who supervised the projects for the project owners) by the contractor wishing to pre-qualify. The interview questions allow qualitative review of work performance for contractors who choose to bid and pre-qualify for public works contracts. The interview questions will be used to examine randomly selected contacts from at least two completed past projects.

In each question, the person being interviewed is asked to rate a certain aspect of contractor's performance, using a scale of 1 to 10. The highest possible score is 120 points. A score of less than **55** points disqualifies the contractor from bidding on projects that are proposed by the public agency. A score of **72 points or more** on each interview is sufficient for a contractor to qualify on this portion of the prequalification process. If the scores resulting from an interview are between 55 and 72, the public agency should conduct another interview to collect additional information.

It is possible that the score given to any interview answer may be challenged in an appeal. For that reason, be sure to: (a) ask the person being interviewed for specific information or details, to explain or substantiate the numerical answer given; and (b) take written notes of the information provided.

Selection of the Interviewer:

- (a) The public agency should select an individual who is at least moderately well informed about public works construction.
- (b) The individual should be unbiased during the interview; this is to ensure accurate implementation of the interview questions.
- (c) The individual should not use examples or deviate from the questions unless the project manager is unclear and prompts further explanation. The interviewer should offer additional explanation of the questions only if he/she is sure of the intent of the question in the interview.

Locating the respondent to interview:

- (a) The interviewer should attempt to contact a project manager of a past project for the interview. The interviewer should be aware that for one interview to be completed, there may be a need to interview multiple individuals. That is, the interviewer may have to contact multiple individuals, such as the project manager concerning the building process, and a financial manager for warranty items, assessed liens, and the like.
- (b) Once reached, the interviewer should review the information contained in the questionnaire of the past project with the project manager. That is, review who is being interviewed and why (purposes of pre-qualifying for public works), the past project type, completion date, and other pertinent information to ensure that the project manager is sure of the project he/she is asked to review.

Interview Length:

- (a) The interview should take 8-12 minutes, under normal circumstances.
- (b) The interviewer, when contacting the project manager, should convey the expected time which it takes to conduct the interview. This is to ensure the individual is not discouraged from taking part in the interview

Conducting the interviews:

- (a) The interview should examine at least two separate past projects listed in the questionnaire.
- (b) After the interview is scored, the interviewer should compare the interview score with the same contractor's score on the written questionnaire. If the ratings (overall scores) are far apart, the interviewer should conduct at least one/two more interviews to determine how past performance should be weighted.
- (c) While conducting the interview, the interviewer should be consistent with the way the questions are presented. That is, if the interviewer changes the way questions are presented during the review, it could potentially change the way the respondent answers the questions and jeopardize the overall scoring.

**REQUEST FOR
PRE-QUALIFICATION OF
BIDDERS COMMENCING
WITH FORTHCOMING
PUBLIC WORK BID**

**REQUEST FOR PRE-QUALIFICATION OF BIDDERS COMMENCING
WITH FORTHCOMING PUBLIC WORK BID
[Pre-qualification procedure begun at the same time as RFP]**

Notice is hereby given that [Public Entity] has determined that all bidders on [Name of specific project] to be undertaken by the [Public Entity] must be pre-qualified prior to submitting a bid on that project. It is mandatory that all Contractors who intend to submit a bid, fully complete the pre-qualification questionnaire, provide all materials requested herein, and be approved by [Public Entity] to be on the final qualified Bidders list. No bid will be accepted from a Contractor that has failed to comply with these requirements. If two or more business entities submit a bid as part of a Joint Venture, or expect to submit a bid as part of a Joint Venture, each entity within the Joint Venture must be separately qualified to bid. The last date to submit a fully completed questionnaire is mm/dd/yy. [35 days prior to the bid closing date]. Contractors are encouraged to submit pre-qualification packages as soon as possible, so that they may be notified of omissions of information to be remedied or of their pre-qualification status well in advance of the bid advertisement for this project.

Answers to questions contained in the attached questionnaire, information about current bonding capacity, notarized statement from surety, and the most recent reviewed or audited financial statements, with accompanying notes and supplemental information, are required. [Public Entity] will use these documents as the basis of rating Contractors in respect to the size and scope of contracts upon which each Contractor is qualified to bid. [Public Entity] reserves the right to check other sources available. [Public Entity's] decision will be based on objective evaluation criteria.

[Public Entity] reserves the right to adjust, increase, limit, suspend or rescind the pre-qualification rating based on subsequently learned information. Contractors whose rating changes sufficient to disqualify them will be notified, and given an opportunity for a hearing consistent with the hearing procedures described below for appealing a pre-qualification rating.

While it is the intent of the pre-qualification questionnaire and documents required therewith to assist [Public Entity] in determining bidder responsibility prior to bid and to aid [Public Entity] in selecting the lowest responsible bidder, neither the fact of pre-qualification, nor any pre-qualification rating, will preclude [Public Entity] from a post-bid consideration and determination of whether a bidder has the quality, fitness, capacity and experience to satisfactorily perform the proposed work, and has demonstrated the requisite trustworthiness.

The pre-qualification packages should be submitted under seal and marked "CONFIDENTIAL" to _____ [address].

The pre-qualification packages (questionnaire answers and financial statements) submitted by Contractors are not public records and are not open to public inspection. All information provided will be kept confidential to the extent permitted by law. However, the contents may be disclosed to third parties for purpose of verification, or investigation of substantial allegations, or in the appeal hearing. State law requires that the names of contractors applying for pre-qualification status shall be public records subject to disclosure, and the first page of the questionnaire will be used for that purpose.

Each questionnaire must be signed under penalty of perjury in the manner designated at the end of the form, by an individual who has the legal authority to bind the Contractor on whose behalf that person is signing. If any information provided by a Contractor becomes inaccurate, the Contractor must immediately notify *[Public Entity]* and provide updated accurate information in writing, under penalty of perjury.

[Public Entity] reserves the right to waive minor irregularities and omissions in the information contained in the pre-qualification application submitted, to make all final determinations, and to determine at any time that the pre-qualification procedures will not be applied to a specific future public works project.

Contractors may submit pre-qualification packages during regular working hours on any day that the offices of *Public Entity* are open. Contractors who submit a complete pre-qualification package will be notified of their qualification status no later than ten business days after submission of the information.

[Public Entity] may refuse to grant pre-qualification where the requested information and materials are not provided, or not provided by mm/dd/yy *[date specified in first paragraph – 35 days before bid closing]* There is no appeal from a refusal for an incomplete or late application, but re-application for a later project is permitted. The closing time for bids will not be changed in order to accommodate supplementation of incomplete submissions, or late submissions.

Where a timely and completed application results in a rating below that necessary to pre-qualify, an appeal can be made. An appeal is begun by the Contractor delivering notice to *[Public Entity]* of its appeal of the decision with respect to its pre-qualification rating, no later than ten business days prior to the closing time for the receipt of bids for this public works project. Without a timely appeal, the Contractor waives any and all rights to challenge the decision of *[Public Entity]*, whether by administrative process, judicial process or any other legal process or proceeding.

If the Contractor gives the required notice of appeal and requests a hearing, the hearing shall be conducted so that it is concluded no later than five business days after *Public Entity's* receipt of the notice of appeal, and no later than five business days prior to the last date for the receipt of bids on the project. The hearing shall be an informal process conducted by a panel to whom the *[governing body of Public Entity]* has delegated responsibility to hear such appeals (the "Appeals Panel"). At or prior to the hearing, the Contractor will be advised of the basis for *[Public Entity's]* pre-qualification determination. The Contractor will be given the opportunity to present information and present reasons in opposition to the rating. Within one day after the conclusion of the hearing, the Appeals Panel will render its decision. It is the intention of *[Public Entity]* that the date for the submission and opening of bids will not be delayed or postponed to allow for completion of an appeal process.

Note: A contractor may be found not pre-qualified for bidding on a specific public works contract to be let by *Public Entity*, or on all contracts to be let by *Public Entity* until the contractor meets *Public Entity's* requirements. In addition, a contractor may be found not pre-qualified for either:

- (1) Omission of requested information or

(2) Falsification of information

* * * * *

NOTICE: To contractors who are using subcontractors for this job, please be advised that *Public Entity* **may** require, as to subcontractors, one of the following:

The qualification of subcontractors in the following crafts or trades, following acceptance of your bid, but before the award is made:

- Pre-qualification of all subcontractors.
- Pre-qualification of subcontractors in certain crafts.
- Post-bid qualification review.

**ANNOUNCEMENT OF
PRE-QUALIFICATION
PROCEDURES AND OPEN
DATES FOR ANNUAL
PRE-QUALIFICATION**

ANNOUNCEMENT OF PRE-QUALIFICATION PROCEDURES AND OPEN DATES FOR ANNUAL PRE-QUALIFICATION

Notice is hereby given that on _____, 2000, the _____ [Public Entity] determined that all bidders on public works to be undertaken by the [Public Entity] must be pre-qualified prior to submitting bids for public works. It is mandatory that all Licensed Contractors who intend to submit bids fully complete the pre-qualification questionnaire, provide all materials requested herein, and be approved by [Public Entity] to be on the final Bidders list. No bid will be accepted from a Contractor that has failed to comply with these requirements. If two or more business entities submit a bid on a project as a Joint Venture, or expect to submit a bid as part of a Joint Venture, each entity within the Joint Venture must be separately qualified to bid.

Pre-qualification applications may be submitted four times each year: (1) from January 1 through January 10; (2) from April 1 through April 10; (3) from July 1 through July 10; and (4) from October 1 through October 10. Contractors who submit a complete pre-qualification package will be notified by first class mail of their qualification status, such notice to be mailed no later than fifteen business days after submission of the information.

Answers to questions contained in the attached questionnaire, information about current bonding capacity on an aggregate and per project limit, notarized statement from surety, and the most recent reviewed or audited financial statements, with accompanying notes and supplemental information, are required. [Public Entity] will use these documents as the basis of rating Contractors in respect to the size and scope of contracts upon which each Contractor is qualified to bid. [Public Entity] reserves the right to check other sources available. [Public Entity's] decision will be based on objective evaluation criteria.

Pre-qualification approval will remain valid for one (1) calendar year from the date of notice of qualification, except that [Public Entity] reserves the right during that calendar year to adjust, increase, limit, suspend or rescind the pre-qualification ratings based on subsequently learned information and after giving notice of the proposed action to the Contractor and an opportunity for a hearing consistent with the hearing procedures described below for appealing a pre-qualification determination.

While it is the intent of the pre-qualification questionnaire and documents required therewith to assist [Public Entity] in determining bidder responsibility prior to the submission of bids and to aid [Public Entity] in selecting the lowest responsible bidder, neither the fact of pre-qualification, nor any pre-qualification rating, will preclude [Public Entity] from a post-bid consideration and determination on a specific project of whether a bidder has the quality, fitness, capacity and experience to satisfactorily perform the proposed work, and has demonstrated the requisite trustworthiness. Contractors are encouraged to submit pre-qualification packages as soon as possible, so that they may be notified of pre-qualification status well in advance of upcoming projects.

The pre-qualification packages should be submitted under seal and marked "CONFIDENTIAL" to _____ [address].

The pre-qualification packages (questionnaire answers and financial statements) submitted by Contractors are not public records and are not open to public inspection. All information provided will be kept confidential to the extent permitted by law, although the contents may be disclosed to third parties for the purpose of verification, investigation of substantial allegations, and in the process of an appeal hearing. State law requires that the names of contractors applying for pre-qualification status shall be public records subject to disclosure, and the first page of the questionnaire will be used for that purpose.

Each questionnaire must be signed under penalty of perjury in the manner designated at the end of the form, by an individual who has the legal authority to bind the Contractor on whose behalf that person is signing. If any information provided by a Contractor becomes inaccurate, the Contractor must immediately notify *[Public Entity]* and provide updated accurate information in writing, under penalty of perjury.

[Public Entity] reserves the right to waive minor irregularities and omissions in the information contained in the pre-qualification application submitted, to make all final determinations, and to determine at any time that the pre-qualification procedures will not be applied to a future public works project.

A contractor who has submitted a completed application form, and who receives a rating of “not qualified” from *[Public Entity]* may appeal that determination. There is no appeal from a finding that a contractor is not pre-qualified because of a failure to submit required information, but re-application during one of the designated time periods is permitted. A contractor may appeal *[Public Entity’s]* decision with respect to its request for pre-qualification, and request a hearing, by giving notice to *[Public Entity]* no later than ten business days after receipt of notice of its qualification status. Unless a Contractor files a timely appeal, the Contractor waives any and all rights to challenge the qualification decision of *[Public Entity]*, whether by administrative process, judicial process or any other legal process or proceeding.

If the Contractor gives the required notice of appeal and requests a hearing, the hearing shall be conducted so that it is concluded no later than ten business days after *Public Entity’s* receipt of its Notice of Appeal. The hearing so provided shall be an informal process conducted by a panel to whom the *[governing body of Public Entity]* has delegated responsibility to hear such appeals (the “Appeals Panel”). At or prior to the hearing, the Contractor will be advised of the basis for *[Public Entity’s]* pre-qualification determination. The Contractor will be given the opportunity to present information and present reasons in opposition to the pre-qualification determination. At the conclusion of the hearing or no later than one day after completion of the hearing, the Appeals Panel will render its decision. The date for submission and opening of bids for a specific project will not be delayed or postponed to allow for completion of an appeal process.

Note: A contractor may be found not pre-qualified for bidding on a specific public works contract to be let by *Public Agency*, or on all contracts to be let by *Public Agency* until the contractor meets *Public Agency’s* requirements. In addition, a contractor may be found not pre-qualified for either:

- (1) Omission of requested information or
- (2) Falsification of information

* * * * *

NOTICE: To contractors who are using subcontractors for this job, please be advised that *Public Entity* **may** require, as to subcontractors, one of the following:

The qualification of subcontractors in the following crafts or trades, following acceptance of your bid, but before the award is made:

- Pre-qualification of all subcontractors.
- Pre-qualification of subcontractors in certain crafts.
- Post-bid qualification review.

SOURCES FOR VERIFICATION OF INFORMATION GIVEN BY CONTRACTORS

SOURCES FOR VERIFICATION OF INFORMATION GIVEN BY CONTRACTORS

A CAUTIONARY NOTE: *The information that will be given to public agencies by contractors seeking pre-qualification is provided under oath, with the understanding that the intentional providing of false information is, in itself, grounds for disqualification. We expect that the information given should be and will be accepted at face value. The following information is provided for use in the few instances in which a public agency reviewing the answers given in a questionnaire has specific reason to believe that one or more answers should be verified by reference to publicly available information.*

Information about a contractor's license(s) (Questionnaire Part I, question 6, and Part II, questions 6 and 9-13)

Names and addresses of licensed contractors, information about the type of license(s) issued and the dates when licenses were issued (and certain other information), are available from the Contractors' State Licensing Board (CSLB), 9821 Business Park Drive, Sacramento, CA 95827. Telephone number 800-321-2752. The CSLB web site for public information is: www.CSLB.ca.gov.

Information about workers' compensation insurance (Part I, question 3 and Part II, questions 32-33)

Every workers' compensation insurance carrier issues to each of its insured businesses a Certificate of Insurance. The contractor should be willing to provide a copy upon request.

Each contractor's Experience Modification Rate for the year should be stated in a letter to the contractor from the contractor's workers' compensation insurance carrier.

Some large companies are legally self-insured for workers' compensation, with the consent and authorization of the Department of Industrial Relations. The names of companies that are legally self-insured are available from the Department's Office of Self-Insurance Plans, Workers' Compensation, 2265 Watt Avenue, Suite 1, Sacramento, CA 95825; (916) 483-3392.

The names of each business's current and recent workers' compensation insurance carriers are available from the Workers' Compensation Insurance Reporting Bureau (WCIRB), 575 Market Street, San Francisco, telephone (415) 777-0777. WCIRB is not a public agency but it provides information to the public. It will provide the names of the current and recent workers' compensation insurance carriers of every employer in California, in response to a written request, for a fee of \$8 for every year for which you seek information.

**Information about whether surety insurance carriers
are “admitted” to do business in California**
(Part I, question 5)

The California Department of Insurance will verify whether an insurance carrier is “admitted” to issue insurance policies within the State. The Department has a “Hot-Line” number – 800-927-4357, and a web-site from which the information is available: www.insurance.ca.gov

Information on disqualification from bidding on public contracts
(Part I, question 8 and Part II, question 15)

Information on the identities of contractors that have been disqualified from bidding on public works contracts is available from the California Labor Commissioner, Division of Labor Standards Enforcement, 455 Golden Gate Avenue, San Francisco, telephone (415) 703-4810.

Information available from the Secretary of State about corporations
(Part II, questions 1a-1d, 2-4)

The California Secretary of State has certain current and historical information about all corporations that operate in California: dates of incorporation, articles of incorporation, the name of the original incorporators, the names of the corporate officers (who are not necessarily the corporate stockholders) and an agent for service of process for the corporation. This information is available from the Secretary of State upon written request. (Secretary of State, Business Programs Division, 1500 Eleventh Street, Sacramento, CA 95814. Telephone (916) 653-2121 or 653-1239). The Secretary of State does not ordinarily have a listing of the names of initial stockholders or current stockholders, and that information is generally not available in any public record.

**Information available from County Clerks about
partnerships and sole proprietorships**
(Part I, questions 1a-1d,2-4)

Every business, including a partnership, that operates under a “fictitious name” (for example, “Ajax Sheet Metal Contractors” or “Smith Brothers Electrical Contractors”) is required to file with the County Clerk in the county in which its home office is located a “Fictitious Business Name” statement. This statement will indicate the owner of the business, if the business is a sole proprietorship, and the names of partners, if the business is a partnership. The information is available to the public from the County Clerk upon request. A written request may be necessary.

**Information about bankruptcy proceedings
(Part II, questions 7 and 8)**

Bankruptcy petitions, which include the names of the person or business that is seeking protection from the Bankruptcy Court, are available for public inspection at the office of the Clerk of each Bankruptcy Court (which are federal courts). In California, Bankruptcy Courts are located in Sacramento, Modesto, Fresno, San Francisco, Oakland, San Jose, Los Angeles, Santa Ana, Riverside, and San Diego. Most documents filed in court in bankruptcy proceedings are available for public inspection, at the Bankruptcy Court clerk's office. Some information on bankruptcy filings may also be available from commercial enterprises that collect and sell information from public records). In addition some information about bankruptcy cases filed August 1990 and later is available on-line through the "PACER" (Public Access to Court Electronic Records) system. To obtain information from PACER, you must register with the system, and pay a fee for the materials obtained. Call 1-800-676-6856 or you may register online at <http://pacer.psc.uscourts.gov/>.

**Information about civil suits and arbitration cases
(Part II, questions 14, 17 and 18)**

Each court keeps records of every civil suit filed in that court, and of the judgments that are issued after trials. However, the exact terms of pre-trial settlements are generally not recorded in court files. Documents related to disputes submitted to arbitration are generally not available for public inspection. Public agencies, however, are required to disclose the terms of such settlements, when documents are requested under the California Public Records Act.

**Information about criminal convictions
(Part I, question 9, and Part II, questions 21, 22, and 23)**

Criminal convictions are a matter of public record. Each courthouse (in both the federal and state court systems) has an index of its own criminal records. In addition, a few data collection businesses have collected criminal conviction information from public records throughout the state, and the collected information about particular individuals or businesses is available for sale from these private businesses.

**Information about Federal court civil and criminal cases
(Part I, question 9)**

Information about federal criminal cases (filed August 1991 and later) and civil cases (filed August 1990 and later) is available on-line through the "PACER" (Public Access to Court Electronic Records) system. To obtain information from PACER, you must register with the system, and pay a fee for the materials obtained. Call 1-800-676-6856 or you may register online at <http://pacer.psc.uscourts.gov/>.

**Information about citations issued for violation of
industrial safety and health laws**
(Part II, questions 28 and 29)

Information about citations issued by both the federal Occupational Safety and Health Administration and the California Division of Occupational Safety and Health (Cal OSHA) are available on a web-site maintained by federal OSHA, <http://www.osha.gov>. At that web site, click on "Library." On the Library page, click on "Statistics and Inspection Data." Next, click on "Establishment Search." When the next screen appears, enter the name of the contractor about whom you seek information in the "Establishment" window. In the "Process" window, enter the number 999999. Click on California in the "State" window. In the "Inspection Date" window, enter "1990." Then click the submit button.

Information about prevailing wage law violations
(Part II, question 34)

Information about recent prevailing wage law violations is available from the Division of Labor Standards Enforcement, at 2424 Arden Way, Suite 360, Sacramento, CA 95825. A model letter asking for such information is enclosed.

**Citations from either Air Quality or Water Quality Board
for violations of regulations**
(Part II, question 30)

Information about citations issued by the California Air Resources Board is available from that agency under the Public Records Act. Their address is 2020 L Street, Sacramento, CA 95814, or Post Office Box 2815, Sacramento, 95812. In addition, Regional Air Quality Management Districts and Regional Water Quality Control Boards throughout the state may issue citations for violation of air quality or water quality standards. Consult the appropriate board in your area for information about how to gather appropriate information.

**Information about state-approved apprenticeship plans
and violations of state apprenticeship laws**
(Part II, questions 36-38)

Information about violations of state apprenticeship laws can be obtained from the Division of Apprenticeship Standards, 455 Golden Gate Avenue, 8th Floor, Post Office Box 420603, San Francisco, CA 94142.

MEMORANDUM

Date: November 1, 2013
To: Board of Directors
From: Communication & Technology Committee Staff
Subject: Discuss Non-Director Participation on Committees

RECOMMENDED ACTION

Provide direction to staff regarding non-director participation on District Committees.

BACKGROUND

At the January 31, 2013 District Board Goal Workshop, Director Gumbinger requested the Communications & Technology Committee discuss non-director participation on District Committees.

Current practice is that when an issue comes up which the Board feels could benefit from public participation, workshops are held and/or an Ad Hoc Committee is formed. Previous District Boards have chosen not to add public members due to the Board's perception of personal agendas, one issue topics and maintaining balanced public input.

Attached are the February 6, 2009 Communications & Technology Committee meeting minutes and the February 18, 2009 Board meeting minutes when public participation was last considered.

MEMORANDUM

Date: February 6, 2009
To: Board of Directors
From: Communication & Technology Committee Staff
Subject: February 6, 2009 Communication & Technology Committee Meeting

Director Taylor called the meeting to order at 10:30 a.m. Present were Directors Taylor and Ferraro. Present from District staff were Edward R. Crouse, General Manager; Greg Remson, Security Chief; Darlene Gillum, Director of Administration; Paul Siebensohn, Director of Field Operations; and Suzanne Lindenfeld, District Secretary. Also, present was Don Sams.

COMMENTS FROM THE PUBLIC

None.

PUBLIC OUTREACH

Board Packet E-Mail Listing

Suzanne gave a brief summary of the process for distributing the Board meeting packets. Packets are completed and distributed to the Directors on the afternoon of the Friday before the Board meeting, with a copy available to the public at the District office. The packet is put on the District's website the following Monday afternoon.

Ed Crouse stated he spoke with Steve Rudolph, District Legal Counsel, regarding this matter and Mr. Rudolph advised it is difficult to create and maintain an e-mail list. Having an e-mail listing opens up the District for complaints. Mr. Rudolph advised to keep the process and availability as is.

Ed stated if documentation for an agenda item is not available at the time of posting the packet to the website, a memo will be put in stating the documentation will be forthcoming. When the documentation is received, copies will be put at the front counter of the District Office for the public. At the Board meeting, an announcement will be made that if additional documentation came in after the posting of the packet and copies will be at the table in the back of the Boardroom.

Director Taylor stated he feels that is sufficient.

Director Ferraro stated that what the District does is within the law.

Don Sams stated he is fine with that change.

Review Communications Matrix

Ed Crouse gave a brief history and summary of the Communication Plan that was developed in 1999. The variety of communication sources is in hopes of reaching more people.

Director Ferraro suggested more personal appearances particularly presentations at schools regarding water use. Director Taylor suggested with prior Board approval, Directors could also make personal appearances representing the District.

Director Ferraro stated that from the residents she has spoken with, most do not read the Pipeline. A discussion followed.

NON-DIRECTOR PARTICIPATION ON COMMITTEES

Ed Crouse stated this item came out of the Board Goal Workshop. Ed stated that when an issue comes up which the Board feels public participation is required, an Ad Hoc Committee is formed. A discussion followed.

Director Taylor suggested the item go to back to the Board with no recommendation. Don Sams stated the District should not expand the public participation in committees past the Ad Hoc Committees. **This item will be added to the February 18, 2009 Board of Directors meeting agenda**

REVIEW JANUARY 9, 2009 COMMITTEE MEETING MINUTES

Director Taylor stated that the Committee should accept the change to the January 9, 2009 Committee meeting minutes as requested by Mr. Sams. Director Ferraro agreed. **This item will be added to the February 18, 2009 Board of Directors meeting agenda as a receive and file under Committee meeting minutes.**

PIPELINE TOPICS

Topics for the next Pipeline will include: golf cart registration and a diversion update. Director Ferraro suggested the next Pipeline's main focus be on water conservation and other water related articles.

DIRECTORS' & STAFF COMMENTS/SUGGESTIONS

Ed Crouse stated an anonymous water waster notification will be placed on the District's website so residents can report water wasters. Chief Remson will be making his Security presentation at the March Board meeting. Paul Siebensohn will be making his annual water report at the April Board meeting.

ADJOURNMENT

The meeting was adjourned at 11:37 a.m.

RANCHO MURIETA COMMUNITY SERVICES DISTRICT

Regular Board of Directors Meeting

MINUTES

February 18, 2009

4:00 p.m. – Closed Session 5:00 p.m. - Open Session

1. CALL TO ORDER/ROLL CALL

President Roberta Belton called the regular meeting of the Board of Directors of Rancho Murieta Community Services District to order at 4:01 p.m. in the District meeting room, 15160 Jackson Road, Rancho Murieta. Directors present were Roberta Belton, Robert Kjome, Betty Ferraro, Steven Mobley, and Richard Taylor. Also present were Edward R. Crouse, General Manager; Darlene Gillum, Director of Administration; Greg Remson, Security Chief; and Paul Siebensohn, Director of Field Operations.

2. EMPLOYEE PROMOTIONS – CERTIFICATIONS

None.

3. BOARD ADJOURNED TO CLOSED SESSION at 4:02 P.M. TO DISCUSS THE FOLLOWING ITEMS:

Under Government Code 54956.8: Real Property Negotiations - Real Property APN 128-0080-067; APN 128-0080-068; APN 128-0080-069; APN 128-0080-076; and APN 128-0100-029. Real Property Negotiator: Edward R. Crouse, General Manager.

Under Government Code 54956(a) Conference with Legal Counsel – Existing Litigation – Hobart v. Bagley, et. al., Sacramento Superior Court Case No. 34-2008-00014844.

4/5. BOARD RECONVENED TO OPEN SESSION AT 5:03 P.M. AND REPORTED THE FOLLOWING:

Steve Rudolph, District Legal Counsel, reported the following:

Under Government Code 54956.8: Real Property Negotiations - Real Property APN 128-0080-067; APN 128-0080-068; APN 128-0080-069; APN 128-0080-076; and APN 128-0100-029. Real Property Negotiator: Edward R. Crouse, General Manager. Board received an update from the General Manager. The Board provided direction to staff. No reportable action.

Under Government Code 54956(a) Conference with Legal Counsel – Existing Litigation – Hobart v. Bagley, et. al., Sacramento Superior Court Case No. 34-2008-00014844. Board received an update from legal counsel. No reportable action.

6. ADOPT AGENDA

Motion/Taylor to adopt the agenda. **Second/Kjome. Ayes: Belton, Kjome, Ferraro, Mobley, Taylor.**

7. COMMENTS FROM THE PUBLIC

Ted Hart, lot 825, commented on the need for the District to publish information regarding the District's water supply and that the new Rancho Murieta Country Club (RMCC) Greens Superintendant also needs to be kept informed of the water availability. Ed Crouse stated a message to the residents regarding water will be included in the February billing.

8. CONSENT CALENDAR

Motion/Belton to accept the Consent Calendar, with a brief discussion on the Finance Committee meeting minutes. **Second/Kjome. Roll Call Vote: Ayes: Belton, Kjome, Ferraro, Mobley, Taylor.**

On Agenda Item 8b3, President Belton stated the Finance Committee would like direction from the Board regarding rate increases and tax increases. A short discussion followed. By consensus, the Board's goal is to have no rate or tax increase. Ed Crouse stated the District should keep the increases as minimal as possible but to keep in mind that the large rate and tax increase last year was due to the lack of small annual rate and tax increases for previous years.

9. STAFF REPORTS

Under Agenda item 9A, President Belton stated that January and February are the lowest months for water production. Ed Crouse stated typically January and February are lowest for water production, although not wastewater into the plant.

Under Agenda Item 9B, President Belton asked if there was anything unusual in the report. Darlene Gillum stated the shut-offs went down from 62 to 56 this month. Darlene also suggested the Board keep in mind that there are some items planned in this year's budget that have been spread equally over a 12 month period that may not have been incurred yet and shown in the monthly financial reports. Director Kjome asked Darlene to provide a list of these items at the next Finance Committee meeting.

President Belton asked if staff received notice from Special District Risk Management Authority (SDRMA) of our rates going down. Darlene stated she has received a letter stating they anticipate a 15% rate reduction.

Under Agenda Item 9c, Director Kjome commented on Gate Officer Eric Dutable passing the bar examination.

Under Agenda Item 9d, Director Taylor stated he would like to draw the public's attention to the Raw Water Supply section of the Water/Wastewater/Utility/Drainage report, which states that as of February 11, 2009, there is an estimated 3400 acre feet in our storage reservoirs, the District has pumped an additional 459 acre feet, and estimate that the reservoirs will be filled by the end of April and have authority to continue to pump through the end of May.

Director Kjome asked if RMCC has provided any feedback regarding the recycled water availability. Paul Siebensohn stated he has received none to date. Paul will be meeting with RMCC's new Greens Superintendent on Friday to discuss issues related to RMCC recycled water availability.

10. CORRESPONDENCE

No correspondence.

11. ATTORNEY FEE REIMBURSEMENT ESCROW ACCOUNT – RECEIVE UPDATE ON ESCROW ACCOUNT FUNDING

Ed Crouse stated the escrow instructions have been completed, signed by all parties and agreed to by the escrow officer. Three out of four release letters for the deposits have been received. The fourth one should be coming in shortly and then transfer of funds can be completed. Director Taylor asked what the total amount of past attorney fees the District is asking for reimbursement for. Ed Crouse stated, through January, it is close to \$129,000.

Don Sams, lot 3127, commented on his concerns regarding the instructions the Board gave to the General Manager in September.

Director Mobley stated there was concern that money was being transferred from another escrow account and that money belonged to the rate payers. This is not true. The money was put there by the developers to use at a later time. They are still obligated to fund that escrow account for the Van Vleck spray fields. Don Sams stated that Director Mobley was not here in September so he is not looking to him for an explanation. A discussion followed.

Director Taylor asked Mr. Sams what the significance is of having as much as \$100,000 up front has to him. Mr. Sams stated this Board directed the General Manager to write a letter to developers stating the amount the Board wanted in funds but the General Manager went on and did whatever he wanted to do. Director Taylor stated that is not the case at all, the reference to \$100,000 was not anything other than an estimate based on what future costs might be.

Director Kjome stated that Ed did carry forth the Board's direction in September, the developers came back and asked for an opportunity to re-enter negotiations under an amended term which the Board felt was acceptable as a means to get repayment for the funds we had already expended and be reimbursed for future legal fees.

12. APPROVE POLICY 2009-01, INTERNET, EMAIL AND ELECTRONIC COMMUNICATION ETHICS, USAGE AND SECURITY POLICY

Darlene Gillum gave a brief summary of the recommendation to approve Policy 2009-01, Internet, Email, and Electronic Communication, Ethics Usage and Security Policy. The changes are 1) no games or other software is permitted unless approved by the Director of Administration/System Administrator, and 2) use of District computers to participate in chat rooms, maintain blogs, and/or communicate in on-line forums is prohibited. A short discussion followed.

Motion/Mobley to approve Policy 2009-01, Internet, Email, and Electronic Communication, Ethics, Usage, and Security Policy. This policy supersedes Policy 2003-03. **Second/Ferraro. Roll Call Vote: Ayes: Belton, Kjome, Ferraro, Mobley, Taylor.**

13. APPROVE POLICY 2009-02, DEVELOPER DEPOSIT POLICY

Ed Crouse gave a brief summary of Policy 93-4 and the recommendation to approve Policy 2009-02, Developer Deposit, which includes a developer deposit agreement. This policy supersedes Policy 93-4.

Don Sams stated Steve Rudolph did a wonderful job on updating the developer deposit policy.

Motion/Kjome to approve Policy 2009-02, Developer Deposit. This policy supersedes Policy 93-4. **Second/Mobley. Roll Call Vote: Ayes: Belton, Kjome, Ferraro, Mobley, Taylor.**

Don Sams asked if staff is still working on Policy 98-1. Ed Crouse stated yes, it will be going to the Finance Committee next month.

14. DISCUSS CONSERVATION PRICING

Ed Crouse stated the Finance Committee requested this item be put on the agenda for the Board to discuss. The District originally looked at a July 1, 2008 roll out. Due to the lack of involvement from the community at the workshops, the Board suggested the District undertake a more comprehensive resident education. A discussion followed.

President Belton asked what time frame is needed to implement conservation pricing. Ed Crouse stated under Prop 218, the District is obligated to post notices of the rate change. That would have to be done at the March Board meeting for a July 1, 2009 implementation date. After discussion, the Board agreed, by consensus that the District will not be rolling out conservation pricing July 1, 2009.

Ted Hart commented on the misconception some residents have that there is a water shortage in Rancho Murieta. Mr. Hart stated he is glad to hear the District Board acknowledge there is no water shortage in Rancho Murieta.

15. DISCUSS NON-DIRECTOR PARTICIPATION ON DISTRICT COMMITTEES

Ed Crouse stated at the Board Goal Workshop, President Belton requested the Communications & Technology Committee discuss participation of non-directors on District committees. After discussion, the Communications & Technology Committee recommended the item be sent back to the Board with no recommendation. After discussion, the Board, by consensus, agreed not to expand public participation on committees, but continue to form Ad Hoc Committees when an issue arises that the Board feels need public participation.

Don Sams commented on how well the Ad Hoc Committee process works.

16. REVIEW AND SELECT CONFERENCE/EDUCATION OPPORTUNITIES

President Belton stated she would like to attend the CSDA 40th Annual Conference in September.

Director Kjome stated he would like information on the CSDA Board's Role in Finance and Fiscal Accountability Conference on May 29, 2009 in Sacramento.

17. MEETING DATES/TIMES FOR THE FOLLOWING COMMITTEES

No changes.

18. COMMENTS/SUGGESTIONS – BOARD MEMBERS AND STAFF

Paul Siebensohn stated that conservation is always important regardless if it's a drought year or not. People need to pay attention to water use.

President Belton stated she was at Murieta Plaza today and watched a sports car park in the handicap parking spot in front of the bank. Chief Remson stated that Security does have the authority to cite for parking violations but it is up to the Board if they want Security to issue parking citations. This item will go to the Security Committee for review.

Director Kjome asked if there is Parks Committee meeting this month. Ed Crouse stated yes it should be. Ed Crouse stated that at the last Parks Committee meeting, Director Kjome submitted the District's request for reimbursement for CEQA fees related to the pedestrian bridge. Director Taylor stated that the RMA Board turned down the District's request for reimbursement at their February 17, 2009 Board meeting and deferred action until September when they feel it is due. The September 2009 date is when interest starts to accrue, not a due date for payment. A short discussion followed. Director Kjome requested Suzanne research the minutes from when the Parks Committee requested the District to undertake being the lead agency.

Ed Crouse gave a brief report back on the February Presidents' meeting. Director Belton; Ed Crouse; Stan Korich, RMCC General Manager; Danise Hetland and Jim Moore from Rancho Murieta Association were in attendance. Vince Lepera, RMCC Board President was not in attendance. The items discussed included: the District and RMA sharing vehicle maintenance, update from RMCC on their new superintendant, update on RMCC pursuing a gas tax rebate, water availability and suggested the new superintendant meet with Paul Siebensohn, informed RMCC the District is receiving less wastewater so far this year and will work with RMCC on alternative strategies for summer irrigation, possibility of moving forward with the North Gate and the Escuela Gate. RMA will be doing some research to see if there are any stumbling blocks in the MBA and/or with their Board on pursuing those projects. President Belton stated the Presidents'

meetings have been changed to the Wednesday prior to both District and RMA Board meetings, every other month.

Ed Crouse stated that he will be out of the office on Thursday and Friday.

19. ADJOURNMENT

Motion/Ferraro to adjourn at 6:32 p.m. Second/Kjome. Ayes: Belton, Kjome, Ferraro, Mobley, Taylor.

Respectfully submitted,

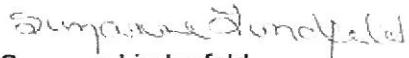

Suzanne Lindenfeld
District Secretary

MEMORANDUM

Date: November 1, 2013
To: Board of Directors
From: Communication & Technology Committee Staff
Subject: Discuss Use of District Letterhead for Directors' Personal Opinions/Comments

RECOMMENDED ACTION

Provide direction to staff regarding use of District property and/or funds to convey personal opinions and/or comments when it differs from the Board's decision.

BACKGROUND

At the October 4, 2013, Communications & Technology Committee meeting, Director Martel asked for a legal opinion and direction regarding his using District letterhead to convey his personal opinion out to the public regarding actions of the Board and District staff when his opinion differs from the Board's decision.

Jonathan Hobbs, District General Counsel, has been consulted on this point, and his opinion is expressed in this memorandum. Ultimately, whether the use of District letterhead to express a view that varies from that of the majority of the Board is allowed is a decision for the Board. District letterhead is property of the District, and the Board may authorize or restrict its use. The Board has already addressed this point by certain policies.

District Policy 2012-01 indicates that Directors should not use District letterhead or staff resources to express a view different than that of the Board. Additionally, the recently adopted Board Guidelines also discourage use of District resources to express a view contrary to the Board's adopted policy. Excerpts of the Guidelines are set forth below, with particularly relevant passages in bold italics:

Speaking as a Private Individual

- ***If you speak as a private citizen at a public gathering, clearly state that you are doing so.***
- ***Keep in mind that even when you say you are speaking as a private individual, many in your audience nevertheless hear your comments in light of your position as a Director of the District.***
- Apply common sense.
- Avoid personal statements that might be interpreted as District policy.

- ***Support District policy, avoiding personal statements that conflict with policy and identify when your personal opinions deviate from Board policy as determined by the Board majority.***
- It is acceptable to speak as an individual on issues not related to District business, but make it clear that your remarks are solely your own.

Communicating with the Media

If you choose to talk with the media, the following practices can help you present your thoughts effectively.

- Do not use the phrase, “No comment,” as this phrase has been stigmatized and may be interpreted negatively.
- Feel free to refer media inquiries to the General Manager or confer with the General Manager prior to speaking with the media to ensure that you are fully briefed on the facts associated with the topic at hand.
- Feel free to use and ask staff to prepare talking points so as to convey a consistent message about District actions.
- ***Clarify when your view is dissenting, but support adopted Board policy even when you are in the minority. Don't stimulate or inflame controversy.***
- ***If you communicate with the media before you vote on a matter, you can inadvertently become a party to a serial meeting in conflict with the Brown Act if the media were to poll other Directors and share with them your predisposition on a matter.***

Should the Board wish to reconsider these policies, it has discretion to do so. However, the current policies would preclude a Director from using District letterhead and/or resources to express a view contrary to that of the Board.

MEMORANDUM

Date: November 7, 2013
To: Board of Directors
From: Personnel Committee Staff
Subject: Approve District Controller Job Description

RECOMMENDED ACTION

Approve the District Controller job description.

BACKGROUND

Attached is the draft proposed job description for a new District Controller.

The duties of the new District Controller are to assume a combination of the hands-on day to day accounting and budget activities performed by the Director of Administration and the Accounting Assistant I/II positions. The current Accounting Assistant II position will not be filled as part of this reorganization. The District Controller is being created as a result of the transition of the Director of Administration into the Assistant General Manager position. The Assistant General Manager will continue to perform the high level duties of the Director of Administration while the day to day accounting responsibilities will be handed down to the District Controller. The proposed salary range for the District Controller is:

NR28	\$6,169	\$7,403	\$8,143
------	---------	---------	---------

This range is 16% higher than the Accounting Supervisor range. It is 37% lower than the Director of Administration range because the District Controller does not have any supervisory duties and it also does not have any responsibility for Human Resources or Information Technology. The proposed range was also validated by comparing similar positions from Amador Water Agency, South Tahoe PUD and Tuolumne Utilities District, which are all agencies used in our most recent salary survey.

The Personnel Committee recommends approval.

RANCHO MURIETA COMMUNITY SERVICES DISTRICT

CONTROLLER

DEPARTMENT: ADMINISTRATION

FLSA OVERTIME STATUS: EXEMPT

BARGAINING UNIT: N/A

APPROVED BY BOARD OF DIRECTORS -

SUMMARY: Under general direction, this position performs a variety of difficult and complex accounting work in support of District financial, accounting, payroll, and related administrative and analytical functions; assists with District audits; supports the Director of Administration in bargaining unit negotiations; and provides accounting training of District staff.

SUPERVISION: Receives general supervision from the Director of Administration.

ESSENTIAL DUTIES AND RESPONSIBILITIES include the following. These are not to be construed as exclusive or all-inclusive. Other duties may be required and assigned.

- Plans, organizes, coordinates and assists with daily accounting and payroll functions
- Performs hands-on accounts payable and daily accounts receivables functions
- Reviews and insures the accuracy of ledger postings and makes adjusting and correcting entries
- Manages and maintains general ledger chart of accounts
- Performs fixed asset management, insuring timely and accurate posting to the general and subsidiary ledgers
- Coordinates and organizes the monthly and annual closing process
- Works closely with District Accounting and Human Resources Specialist in planning and prioritizing the day to day activities of the District's accounting functions
- Prepares draft monthly Board financial statements for Director of Administration analytical review and write-up of data changes
- Performs periodic internal audits of accounting records and operational processes to insure control procedures are working as intended
- Assists with annual audits conducted by outside auditors, including preparing the requested audit materials, schedules, and certain reports.

- Supports the Director of Administration in confidential bargaining unit negotiations by creating financial analysis of MOU costs and budget availability; may also participate in negotiation meetings
- Prepares the financial statements, tables, and other financial data for the annual report
- Performs monthly bank account reconciliations for review by Director of Administration
- Assists District management with development of the annual budget, including rate development, and prepares monthly reports of budget-to-actual results
- Assists other departments with questions on the budget, proper coding, document processing, and other accounting-related activities
- Monitors cash accounts and records monthly disbursements
- Performs financial analysis on annual and periodic reporting
- Researches latest accounting statements and recommends implementation process
- Performs special analytical studies as directed by the Director of Administration

QUALIFICATION REQUIREMENTS: Knowledgeable of principles and practices of Generally Accepted Accounting Principles, governmental fund accounting practices including internal controls, auditing, budgeting and rate setting; payroll processing; cash handling processes, including bank deposits; procedures, policies, rules and practices affecting the development, maintenance and control of fiscal record keeping systems; computer hardware and software programs such as MS Office, Great Plains, and Utility Star; principles and practices of pertinent Federal, State, and local laws, rules, and regulations governing accountability of funds in public agencies; District policies, rules and regulations.

Ability to communicate effectively, both orally and in writing; use independent judgment in fairly non-routine situations, such as but not limited to calculating anticipated revenue and/or expenditures; prioritize workload efficiently, without direct instruction, to meet deadlines under changing conditions; to be detail and results oriented with initiative and follow through; analyze problems, identify alternative solutions, project consequences of proposed actions and implement recommendations in support of goals; establish and maintain effective, cooperative working relationships; and interpret, explain and apply generally accepted accounting and auditing principles.

EDUCATION AND/OR EXPERIENCE: Bachelors degree required, preferably in accounting, business or public administration or related field, and three years of increasingly responsible work experience performing accounting, budget preparation, personnel management, public program analysis, and analytical report preparation.

LICENSE AND/OR CERTIFICATES: Possession of the category of California Driver's license required by the State Department of Motor Vehicles to perform the essential duties of the position. Continued maintenance of a valid driver's license, insurability, and compliance with established District vehicle operation standards are a condition of continuing employment.

PHYSICAL DEMANDS: Ability to operate a variety of automated office machines; reasonable typing and writing skills; exert light physical effort in sedentary to light work involving sitting most of the time, but may involve walking or moving from one area to another or standing for brief periods of time.

Ability to exert negligible amount of force frequently or constantly to lift, carry, push, pull or otherwise move objects.

The employee must occasionally lift and/or move up to 25 pounds.

WORK ENVIRONMENT: The work environment characteristics described here are representative of those an employee encounters while performing the essential functions of this job. Reasonable accommodations may be made to enable individuals with disabilities to perform the essential functions.

The noise level in the work environment is usually quiet.

MEMORANDUM

Date: November 7, 2013
To: Board of Directors
From: Personnel Committee Staff
Subject: Approve Accounting and Human Resources Specialist Job Description

RECOMMENDED ACTION

Approve the Accounting and Human Resources Specialist Job Description.

BACKGROUND

Attached is the draft of the proposed job descriptions for a new Accounting and Human Resources Specialist positions.

The primary duties of the new Accounting and Human Resources Specialist are to perform all human resource functions, oversee the District's billing system, Accounts Receivable and the associated processes, payroll processing, resolve special Accounts Payable issues, and oversee the District's Information Technology needs. The proposed salary range for the Accounting and Human Resources Specialist is:

NR18	\$4,834	\$5,800	\$6,380
-------------	---------	---------	---------

This range is established at 10% below the Accounting Supervisor range. The proposed range was also validated by comparing similar positions from the City of Folsom, Amador Water Agency, Calaveras County Water District and Tuolumne Utilities District, which are all agencies used in our most recent salary survey.

The Personnel Committee recommends approval.

RANCHO MURIETA COMMUNITY SERVICES DISTRICT

ACCOUNTING AND HUMAN RESOURCES SPECIALIST

DEPARTMENT: ADMINISTRATION

FLSA OVERTIME STATUS: EXEMPT

BARGAINING UNIT: N/A

APPROVED BY BOARD OF DIRECTORS –

SUMMARY: Uses discretion and independent judgment to perform difficult and responsible clerical accounting and human resources work involving planning, organizing, coordinating and performing functions to include purchasing, finance/accounting, payroll, human resources, benefits, risk management, customer service; supports the Director of Administration in confidential bargaining unit negotiations; and computer network maintenance.

SUPERVISION: Receives general supervision from the Director of Administration.

ESSENTIAL DUTIES AND RESPONSIBILITIES include the following. These are not to be construed as exclusive or all-inclusive. Other duties may be required and assigned.

- Processes and performs accounting activities including accounts payable, accounts receivable, bank deposits and associated general journal preparation and entry
- Manages and maintains the District billing system including monitoring of high usage and zero reads, coordinates with Utility staff on the installation or replacement of meters, records property ownership changes and manages the escrow process, and maintains accurate billing rates
- Processes District rebate applications and manages to rebate budget
- Processes and reconciles employee and Director expense reports
- Works closely with District Controller in planning and prioritizing the day to day activities of the District's accounting functions
- Assists Director of Administration with the compilation of confidential information related to confidential bargaining unit negotiations
- Performs District payroll processing; maintains personnel records, salary information, surveys and benefits coordination and advises on personnel issues

- Assists in planning, organizing and directing all phases of the District's Human Resources Department, including recruitment and selection, policy and procedure development, classification and compensation analysis, employee training and development, labor relations, risk management and safety
- Provides information to District departments, staff and the general public on human resources law, policies, and procedures; develops manuals, policies, procedures and forms necessary to the effective operation of the office
- Conducts compensation and classifications studies and provides results to the Director of Administration
- Maintains required reports for the District Safety Committee
- Manages and monitors the performance evaluation system of the District insuring the completion of accurate, objective and timely performance evaluations
- Coordinates and monitors the worker's compensation claims of the District acting as a liaison with the department head, supervisor, employee and the District's risk management program director
- Assists in the preparation and distribution of Personnel Employee Manuals; maintains personnel records, salary information, surveys and benefits coordination and advises on personnel issues
- Maintains and manages computer network with assistance from outside vendor
- Maintains and manages the accounting, billing, meter reading and payroll software programs including annual updates as appropriate

QUALIFICATION REQUIREMENTS:

Knowledgeable in principles and practices of public employment administration, including employee health and welfare benefit administration; processing payroll, accounts payable, accounts receivable, enforcement of cash handling process and bank deposits; procedures, policies, rules and practices affecting the development, maintenance and control of fiscal and personnel record keeping systems; principles and practices of governmental accounting, auditing, and budgeting; Federal, State, and local laws, rules, and regulations governing accountability of funds in public agencies and public employment administration; District policies, rules and regulations and be proficient with computer hardware and software programs such as MS Office, Great Plains and Utility Star.

Ability to: communicate effectively, both orally and in writing, utilize independent judgment in the execution of job responsibilities, prioritize workload without direct instruction to meet deadlines under changing conditions; establish and maintain effective, cooperative working relationships; and interpret, explain and apply relevant payroll tax laws and employment regulations.

EDUCATION AND/OR EXPERIENCE:

Any combination of training and experience providing the required knowledge and abilities is qualifying. A typical way to obtain this knowledge and ability would be:

Minimum Education: High School diploma and/or equivalent; although a Bachelor's degree in business or accounting (or closely related field) is highly desirable; *or*

Two years of technical experience in financial, accounting, or personnel recordkeeping activities and one year of experience in general office administration sufficient to demonstrate the ability to perform a variety of administrative, personnel, customer services, and computer network maintenance in an independent manner; *or*

Possession of a four-year college degree with a major emphasis in accounting, business management, or a closely related field (Two years of experience performing duties comparable to the Accounting Assistant II at Rancho Murieta Community Services District may be substituted for the college degree).

LICENSE AND/OR CERTIFICATES:

Possession of the category of California Driver's license required by the State Department of Motor Vehicles to perform the essential duties of the position. Continued maintenance of a valid driver's license, insurability, and compliance with established District vehicle operation standards are a condition of continuing employment.

OTHER SKILLS AND ABILITIES:

Knowledge of operation, administration, policies and procedures relating to government administration and finance; data management including word processing, spreadsheet and data base principles; and computer network maintenance.

PHYSICAL DEMANDS:

Ability to operate a variety of automated office machines; reasonable typing and writing skills; exert light physical effort in sedentary to light work involving sitting most of the time, but may involve walking or moving from one area to another or standing for brief periods of time.

Ability to exert negligible amount of force frequently or constantly to lift, carry, push, pull or otherwise move objects.

The employee must occasionally lift and/or move up to 25 pounds.

WORK ENVIRONMENT:

The work environment characteristics described here are representative of those an employee encounters while performing the essential functions of this job. Reasonable accommodations may be made to enable individuals with disabilities to perform the essential functions.

The noise level in the work environment is usually quiet.



MEMORANDUM

Date: November 7, 2013
To: Board of Directors
From: Personnel Committee Staff
Subject: Approve Revised Job Descriptions

RECOMMENDED ACTION

Approve revisions to the Director of Administration, Accounting Assistant I & II and Office Assistant I & II Job descriptions.

BACKGROUND

Attached are the updated job descriptions for Director of Administration, Accounting Assistant I & II, and Office Assistant I & II.

The revisions to the Accounting Assistant I & II and the Office Assistant I & II reflect that with the reorganization, those positions will be directly supervised by the Director of Administration. Even though the Accounting Assistant position is unfilled in the Administration Department reorganization, the job descriptions are included only to keep them updated with current reporting structure. The Office Assistant I & II job descriptions are being updated to reflect that they will be directly supervised by the Director of Administration.

The Personnel Committee recommends adoption.

RANCHO MURIETA COMMUNITY SERVICES DISTRICT

DIRECTOR OF ADMINISTRATION

DEPARTMENT: ADMINISTRATION

FLSA OVERTIME STATUS: EXEMPT

BARGAINING UNIT: N/A

APPROVED BY BOARD OF DIRECTORS – xx/xx/xxxx

SUMMARY: Responsible for the functions and staff of administrative services. Functions include purchasing, contract coordination, finance/accounting, direction and evaluation of administrative staff, personnel, risk management, computer systems management.

SUPERVISION: Receives general supervision from the General Manager. Provides direct supervision over the ~~Accounting Supervisor~~Controller, Accounting and HR Specialist, Accounting Assistant I/II and Office Assistant I/II.

ESSENTIAL DUTIES AND RESPONSIBILITIES include the following. These are not to be construed as exclusive or all-inclusive. Other duties may be required and assigned.

- Oversees and administers the business and front office operations of the District, providing assignment, direction and evaluation of Department staff members;
- coordinates projects, research and reports pertaining to District operations and administration; drafts, recommends and implements operational procedures related to District operations, systems, staff development, and administration;
- maintains records and coordinates the execution of all on-going or occasional contracts entered into by the District;
- prepares and administers the District budget; reviews and compiles all budgets, creating spreadsheets, reports and forms for approval of the Board of Directors; responsible for ongoing oversight of departmental budgets and District practices in adhering to those budgets;
- provides research, bidding, comparisons, and recommendations to General Manager and Board on fixed asset purchases; maintains District equipment and supply inventory;
- manages the District risk management program; coordinates District claims with insurance carrier, claims representative and legal counsel; assists in preparation and administration of District's injury and illness prevention program;

- oversees preparation and distribution of Personnel Employee Manuals; oversees staff training;
- manages and maintains all District computer equipment, software, and office automated equipment and software purchases; provides staff orientation, training or assistance with all equipment, computers and software;
- attends meetings of the District Board of Directors; prepares detailed staff reports and makes presentations to the Board;
- develops long range strategic and financial goals for the department;
- serves as District Finance Officer, subject to appointment by the Board of Directors.

QUALIFICATION REQUIREMENTS:

Knowledgeable in processing payroll, accounts payable, accounts receivable, enforcement of cash handling process and bank deposits. Procedures, policies, rules and practices affecting the development, maintenance and control of fiscal and personnel record keeping systems. Principles and practices of governmental accounting, auditing, and budgeting. Federal, state, and local laws, rules, regulations governing accountability of funds in public agencies. District policies, rules and regulations. Basic budget preparation procedures.

SUPERVISORY RESPONSIBILITIES:

Ability to assign, review, plan, coordinate and guide the work of other employees; recommend the transfer, promotion, salary increase, discipline or discharge of staff; evaluate the work of employees and prepare performance appraisals; promote staff development and motivation and to train staff; analyze problems that arise in the areas under supervision and recommend solutions; preparation procedures and processes for tracking and evaluating the budget through the year.

Ability to use independent judgment in fairly non-routine situations, such as but not limited to, calculating anticipated revenue and/or expenditures; ensuring adequate supervision of programs.

EDUCATION AND/OR EXPERIENCE:

Education:

BA/BS degree in accounting, finance, business administration, public administration or closely related field.

Experience: Three (3) to five (5), Five (5) to seven (7) years of increasingly responsible experience performing effective governmental administration including supervision, budget preparation, personnel management, public program analysis, analytical report

preparation, and computer system (hardware, software, network and peripherals) application maintenance.

LICENSE AND/OR CERTIFICATES:

Possession of the category of a current California Driver's license required by the State Department of Motor Vehicles to perform the essential duties of the position. Continued maintenance of a valid driver's license, insurability, and compliance with established District vehicle operation standards are a condition of continuing employment.

~~OTHER SKILLS AND ABILITIES:~~

~~Knowledge of supervisory principles and practices; operation, administration, policies and procedures relating to government administration and finance; data management including word processing, spreadsheet and data base principles; client server local area networks, and methods of preparing and monitoring annual budgets.~~

PHYSICAL DEMANDS:

Ability to operate a variety of automated office machines; reasonable typing and writing skills; exert light physical effort in sedentary to light work involving sitting most of the time, but may involve walking or moving from one area to another or standing for brief periods of time.

Ability to exert negligible amount of force frequently or constantly to lift, carry, push, pull or otherwise move objects.

The employee must occasionally lift and/or move up to 25 pounds.

WORK ENVIRONMENT:

The work environment characteristics described here are representative of those an employee encounters while performing the essential functions of this job. Reasonable accommodations may be made to enable individuals with disabilities to perform the essential functions.

While performing the duties of this job, the employee is occasionally exposed to risk of electrical shock.

The noise level in the work environment is usually quiet.

RANCHO MURIETA COMMUNITY SERVICES DISTRICT

ACCOUNTING ASSISTANT I

DEPARTMENT: ADMINISTRATION

FLSA OVERTIME STATUS: NON-EXEMPT

BARGAINING UNIT: OPERATING ENGINEERS LOCAL 3

APPROVED BY BOARD OF DIRECTORS – 02/16/05

SUMMARY: To perform professional accounting and financial recordkeeping work; to assist in the preparation of financial statements, documents, analyses and reports; to personally perform complex and detailed accounting work; and to perform other job related work as required.

SUPERVISION: Receives direct supervision from the ~~Accounting Supervisor~~Director of Administration.

ESSENTIAL DUTIES AND RESPONSIBILITIES include the following. Other duties may be required and assigned.

- Performs a variety of technical and specialized financial, personnel, budgetary and statistical recordkeeping work in District general ledger, accounts payable and receivables, water billing, payroll, and budget activities;
- assists in the establishment of forms and procedures relating to financial recordkeeping methods;
- gathers and organizes data to assist District management in the preparation of reports and recommendations; assists in the preparation of special financial, statistical, budgetary and analytical studies and reports;
- performs duties involving the receipt, balancing and posting of cash funds; gathers, assembles, tabulates, checks and files financial data;
- performs the duties of other office support staff in a backup and fill-in capacity as needed.

DISTINGUISHING CHARACTERISTICS:

This is the trainee and first working level in the Accounting class series. Incumbents in this class work under supervision in any of the work areas specified in the definition above. They perform less complex tasks and receive on-the-job training in the performance of more complex duties. Incumbents will be assigned specific duties according to the District's needs and the individual's ability. As an incumbent gains skill and performs more difficult

work through experience and training and a desired level of proficiency is reached, promotion to a higher level classification can be reasonably expected.

QUALIFICATION REQUIREMENTS:

Knowledgeable in procedures, policies, rules and practices affecting the development, maintenance and control of fiscal and personnel recordkeeping systems. Practices of financial, personnel and statistical recordkeeping, including automated accounting and bookkeeping systems. Basic budget preparation procedures. Filing methods and procedures. Correct English usage, spelling, grammar and punctuation. Basic governmental accounting principles and procedures. Modern office practices, procedures and equipment.

Ability to perform a variety of arithmetical calculations with speed and accuracy. Interpret and apply laws, regulations and policies. Maintain cooperative working relationships with those contacted in the course of the work. Carry out directions independent of close supervision. Operate computer and related accounting and office support software.

EDUCATION AND/OR EXPERIENCE:

Any combination of training and experience providing the required knowledge and ability is qualifying. A typical way to obtain this knowledge and ability would be:

Minimum Education: High School diploma and/or equivalent.

Two years of technical experience in financial, accounting, personnel or statistical recordkeeping activities; *or*

Possession of a two year college degree with a major emphasis in accounting, business management, or a closely related field (Two years of experience performing comparable duties to this position may be substituted for the college degree).

LICENSE AND/OR CERTIFICATES:

Possession of the category of California Driver's license required by the State Department of Motor Vehicles to perform the essential duties of the position. Continued maintenance of a valid driver's license, insurability, and compliance with established District vehicle operation standards are a condition of continuing employment.

PHYSICAL DEMANDS:

Ability to operate a variety of automated office machines; reasonable typing and writing skills; exert light physical effort in sedentary to light work involving sitting most of the time, but may involve walking or moving from one area to another or standing for brief periods of time.

Ability to exert negligible amount of force frequently or constantly to lift, carry, push, pull or otherwise move objects.

The employee must occasionally lift and/or move up to 25 pounds.

WORK ENVIRONMENT:

The work environment characteristics described here are representative of those an employee encounters while performing the essential functions of this job. Reasonable accommodations may be made to enable individuals with disabilities to perform the essential functions.

The noise level in the work environment is usually quiet.



RANCHO MURIETA COMMUNITY SERVICES DISTRICT

ACCOUNTING ASSISTANT II

DEPARTMENT: ADMINISTRATION

FLSA OVERTIME STATUS: NON-EXEMPT

BARGAINING UNIT: OPERATING ENGINEERS LOCAL 3

APPROVED BY BOARD OF DIRECTORS - 02/16/05

SUMMARY: To perform professional accounting and financial recordkeeping work; to assist in the preparation of financial statements, documents, analyses and reports; to personally perform complex and detailed accounting work; and to perform other job related work as required.

SUPERVISION: Receives direct supervision from the ~~Accounting Supervisor~~Director of Administration.

ESSENTIAL DUTIES AND RESPONSIBILITIES include the following. Other duties may be required and assigned.

- Performs a variety of technical and specialized financial, personnel, budgetary and statistical recordkeeping work in District general ledger, accounts payable and receivables, water billing, payroll, and budget activities;
- assists in the establishment of forms and procedures relating to financial recordkeeping methods;
- gathers and organizes data to assist District management in the preparation of reports and recommendations; assists in the preparation of special financial, statistical, budgetary and analytical studies and reports;
- performs duties involving the receipt, balancing and posting of cash funds; gathers, assembles, tabulates, checks and files financial data;
- performs the duties of other office support staff in a backup and fill-in capacity as needed.

DISTINGUISHING CHARACTERISTICS:

This is the full working level in the Accounting class series. Incumbents in this class work under minimal supervision in any of the work areas specified in the definition above. They are expected to perform all types of accounting support and professional accounting work related to the development and maintenance of District fiscal and accounting systems.

Incumbents will be assigned specific duties according to the District's needs and the individual's ability.

QUALIFICATION REQUIREMENTS:

Knowledgeable in procedures, policies, rules and practices affecting the development, maintenance and control of fiscal and personnel recordkeeping systems. Practices of financial, personnel and statistical recordkeeping, including automated accounting and bookkeeping systems. Basic budget preparation procedures. Filing methods and procedures. Correct English usage, spelling, grammar and punctuation. Basic governmental accounting principles and procedures. Modern office practices, procedures and equipment.

Ability to perform a variety of arithmetical calculations with speed and accuracy. Interpret and apply laws, regulations and policies. Maintain cooperative working relationships with those contacted in the course of the work. Carry out directions independent of close supervision. Operate computer and related accounting and office support software.

EDUCATION AND/OR EXPERIENCE:

Any combination of training and experience providing the required knowledge and ability is qualifying. A typical way to obtain this knowledge and ability would be:

Minimum Education: High School diploma and/or equivalent.

Two years of technical experience in financial, accounting, personnel or statistical recordkeeping activities; *or*

Possession of a four year college degree with a major emphasis in accounting, business management, or a closely related field (Two years of experience performing duties comparable to the Accounting Assistant I may be substituted for the college degree).

LICENSE AND/OR CERTIFICATES:

Possession of the category of California Driver's license required by the State Department of Motor Vehicles to perform the essential duties of the position. Continued maintenance of a valid driver's license, insurability, and compliance with established District vehicle operation standards are a condition of continuing employment.

PHYSICAL DEMANDS:

Ability to operate a variety of automated office machines; reasonable typing and writing skills; exert light physical effort in sedentary to light work involving sitting most of the time, but may involve walking or moving from one area to another or standing for brief periods of time.

Ability to exert negligible amount of force frequently or constantly to lift, carry, push, pull or otherwise move objects.

The employee must occasionally lift and/or move up to 25 pounds.

WORK ENVIRONMENT:

The work environment characteristics described here are representative of those an employee encounters while performing the essential functions of this job. Reasonable accommodations may be made to enable individuals with disabilities to perform the essential functions.

The noise level in the work environment is usually quiet.

DRAFT

RANCHO MURIETA COMMUNITY SERVICES DISTRICT

OFFICE ASSISTANT I

DEPARTMENT: ADMINISTRATION

FLSA OVERTIME STATUS: NON-EXEMPT

BARGAINING UNIT: OPERATING ENGINEERS LOCAL 3

APPROVED BY BOARD OF DIRECTORS – 01/21/09

SUMMARY: To perform the duties of receptionist/customer service and to perform a wide variety of document preparation, data entry, entry level accounting and general office support involving extensive public contact work; to perform other related work as required.

SUPERVISION: Receives direct supervision from the ~~Accounting Supervisor~~ Director of Administration.

ESSENTIAL DUTIES AND RESPONSIBILITIES include the following. Other duties may be required and assigned.

- Serves as receptionist and customer service representative, greets the public and provides information on routine questions and directs complex technical questions or unusual requests to appropriate staff members; takes and relays messages;
- performs a wide variety of office assistance and general office support work including document preparation, filing, answering the telephone and assisting the public;
- performs kitchen duties as required;
- types forms, memoranda, and miscellaneous correspondence
- sets up and maintains a variety of files; sorts and files documents and registers information;
- collects, sorts, date stamps and distributes mail; prepares and sends out welcome letters/packets to new customers; orders and maintains adequate office supplies;
- receives, prepares receipts, records and deposits funds;
- assists accounting class staff with duties involving the receipt, balancing and posting of cash funds; and the gathering, assembling, tabulating, checking and filing of financial data;
- responsible for maintaining office equipment in working order and arranging training;

- assists accounting class staff with duties involving data entry of accounts payable, purchase orders and timesheet distribution information;
- performs the duties of other office support staff in a backup and fill-in capacity as needed.

DISTINGUISHING CHARACTERISTICS:

Office Assistant I is the entrance level for office support employees. Incumbents in this class work under supervision in any of the work areas specified in the definition above. They perform less complex tasks and receive on-the-job training in the performance of more complex duties. Incumbents will be assigned specific duties according to the District's needs and the individual's ability. As an incumbent gains skill and performs more difficult work through experience and training and a desired level of proficiency is reached, promotion to a higher level classification can be reasonably expected.

QUALIFICATION REQUIREMENTS:

Knowledgeable in receptionist and telephone techniques, basic accounting concepts, math, filing and recordkeeping procedures, standard office machines, equipment and software. Proper use of English language, spelling, grammar and punctuation.

Ability to meet the public with courtesy and tact. Perform routine office assistance and office support work. Learn office methods, rules and policies. Understand and carry out oral and written directions. Maintain cooperative working relationships with those contacted in the course of the work. Carry out directions independent of close supervision. Operate computer and related accounting and office support software.

EDUCATION AND/OR EXPERIENCE:

Any combination of training and experience providing the required knowledge and ability is qualifying. A typical way to obtain this knowledge and ability would be:

Minimum Education: High School diploma and/or equivalent.

No experience required.

LICENSE AND/OR CERTIFICATES:

Possession of the category of California Driver's license required by the State Department of Motor Vehicles to perform the essential duties of the position. Continued maintenance of a valid driver's license, insurability, and compliance with established District vehicle operation standards are a condition of continuing employment.

PHYSICAL DEMANDS:

Ability to operate a variety of automated office machines; reasonable typing and writing skills; exert light physical effort in sedentary to light work involving sitting most of the

time, but may involve walking or moving from one area to another or standing for brief periods of time.

Ability to exert negligible amount of force frequently or constantly to lift, carry, push, pull or otherwise move objects.

The employee must occasionally lift and/or move up to 25 pounds.

WORK ENVIRONMENT:

The work environment characteristics described here are representative of those an employee encounters while performing the essential functions of this job. Reasonable accommodations may be made to enable individuals with disabilities to perform the essential functions.

The noise level in the work environment is usually quiet.

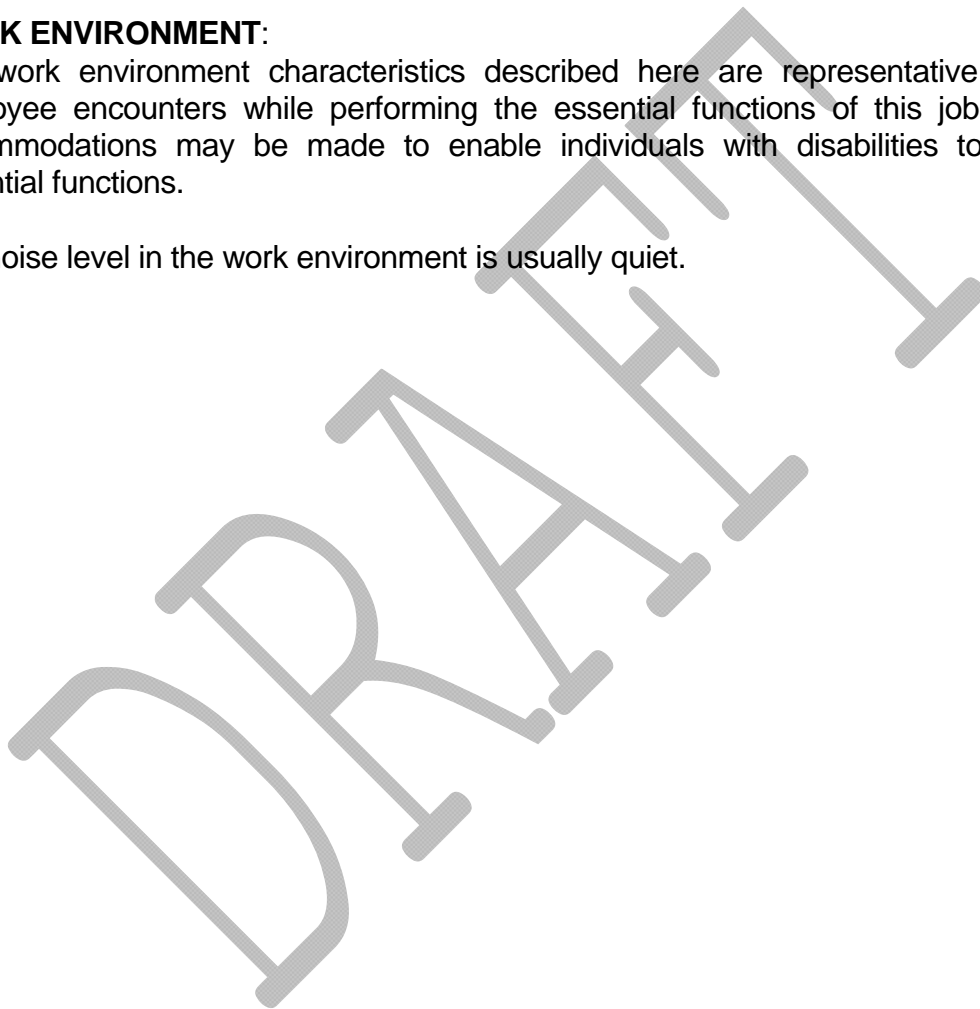

RANCHO MURIETA COMMUNITY SERVICES DISTRICT

OFFICE ASSISTANT II

DEPARTMENT: ADMINISTRATION

FLSA OVERTIME STATUS: NON-EXEMPT

BARGAINING UNIT: OPERATING ENGINEERS LOCAL 3

APPROVED BY BOARD OF DIRECTORS – 01/21/09

SUMMARY: To perform the duties of receptionist/customer service and to perform a wide variety of document preparation, data entry, entry level accounting and general office support involving extensive public contact work; to perform other related work as required.

SUPERVISION: Receives direct supervision from the ~~Accounting Supervisor~~Director of Administration.

ESSENTIAL DUTIES AND RESPONSIBILITIES include the following. Other duties may be required and assigned.

- Serves as receptionist and customer service representative, greets the public and provides information on routine questions and directs complex technical questions or unusual requests to appropriate staff members; takes and relays messages;
- performs a wide variety of office assistance and general office support work including document preparation, filing, answering the telephone and assisting the public;
- performs kitchen duties as required;
- types forms, memoranda, and miscellaneous correspondence;
- sets up and maintains a variety of files; sorts and files documents and registers information;
- collects, sorts, date stamps and distributes mail; prepares and sends out welcome letters/packets to new customers; orders and maintains adequate office supplies;
- receives, prepares receipts, records and deposits funds;
- assists accounting class staff with duties involving the receipt, balancing and posting of cash funds; and the gathering, assembling, tabulating, checking and filing of financial data;
- responsible for maintaining office equipment in working order and arranging training;

- assists accounting class staff with duties involving data entry of accounts payable, purchase orders and timesheet distribution information;
- performs the duties of other office support staff in a backup and fill-in capacity as needed.

DISTINGUISHING CHARACTERISTICS:

This is the full working level in the Office Support series. Incumbents in this class work under minimal supervision in any of the work areas specified in the definition above. They are expected to perform complex tasks. Incumbents will be assigned specific duties according to the District's needs and the individual's ability.

QUALIFICATION REQUIREMENTS:

Knowledgeable in receptionist and telephone techniques, basic accounting concepts, math, filing and recordkeeping procedures, standard office machines, equipment and software. Proper use of English language, spelling, grammar and punctuation.

Ability to meet the public with courtesy and tact. Perform routine office assistance and office support work. Learn office methods, rules and policies. Understand and carry out oral and written directions. Maintain cooperative working relationships with those contacted in the course of the work. Carry out directions independent of close supervision. Operate computer and related accounting and office support software.

EDUCATION AND/OR EXPERIENCE:

Any combination of training and experience providing the required knowledge and ability is qualifying. A typical way to obtain this knowledge and ability would be:

Minimum Education: High School diploma and/or equivalent.

Office Assistant II: - One year of experience as an Office Assistant I; *or*

Two years of office support experience sufficient to demonstrate the ability to perform a variety of receptionist, customer service, basic accounting and general office support work in an independent manner.

LICENSE AND/OR CERTIFICATES:

Possession of the category of California Driver's license required by the State Department of Motor Vehicles to perform the essential duties of the position. Continued maintenance of a valid driver's license, insurability, and compliance with established District vehicle operation standards are a condition of continuing employment.

PHYSICAL DEMANDS:

Ability to operate a variety of automated office machines; reasonable typing and writing

skills; exert light physical effort in sedentary to light work involving sitting most of the time, but may involve walking or moving from one area to another or standing for brief periods of time.

Ability to exert negligible amount of force frequently or constantly to lift, carry, push, pull or otherwise move objects.

The employee must occasionally lift and/or move up to 25 pounds.

WORK ENVIRONMENT:

The work environment characteristics described here are representative of those an employee encounters while performing the essential functions of this job. Reasonable accommodations may be made to enable individuals with disabilities to perform the essential functions.

The noise level in the work environment is usually quiet.

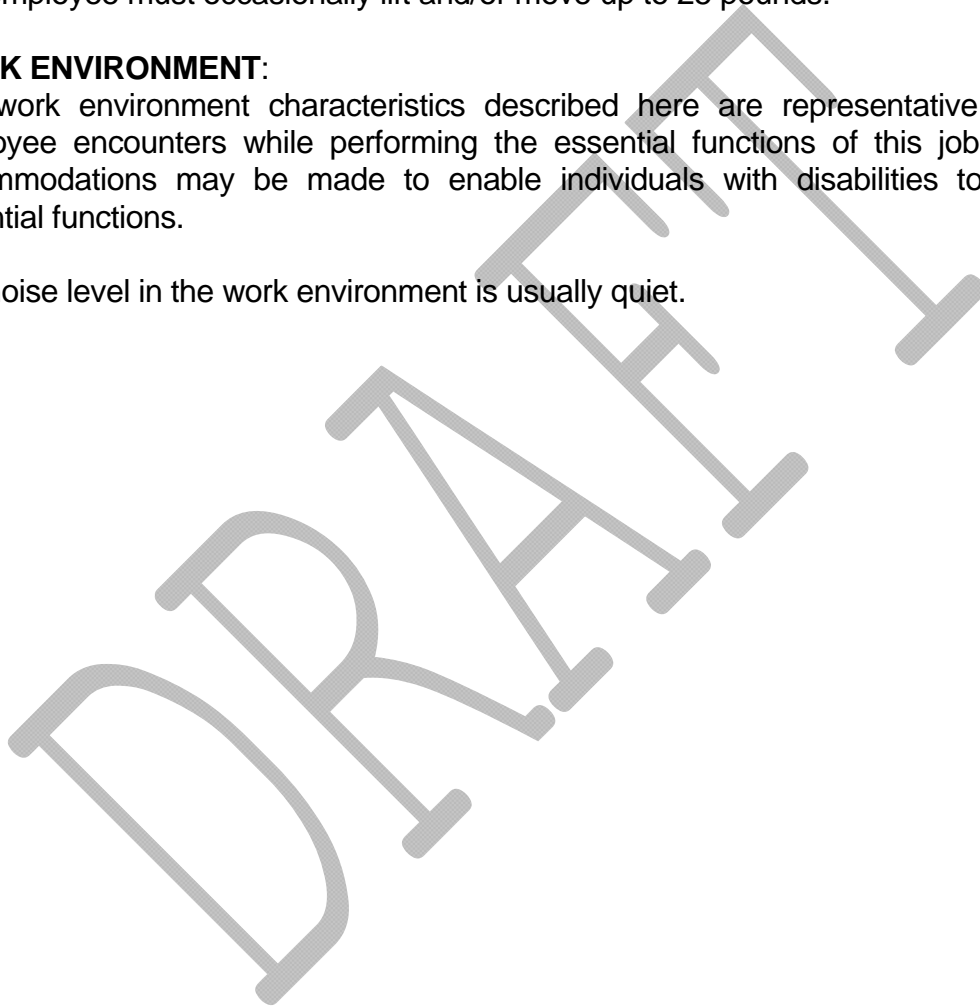

CONFERENCE/EDUCATION SCHEDULE

Date: November 12, 2013
To: Board of Directors
From: Suzanne Lindenfeld, District Secretary
Subject: Review Upcoming Conference/Education Opportunities

This report is prepared in order to notify Directors of upcoming educational opportunities. Directors interested in attending specific events or conferences should contact me to confirm attendance for reservation purposes. The Board will discuss any requests from Board members desiring to attend upcoming conferences and approve those requests as deemed appropriate.

Board members must provide brief reports on meetings that they have attended at the District's expense. (AB 1234).

The upcoming conferences/educational opportunities include the following:

CALIFORNIA SPECIAL DISTRICT ASSOCIATION (CSDA)

How to be an Effective Board Member	January 30, 2014	Sacramento
Board Secretary/Clerk Conference	February 27, 2014	Napa
2014 Special District Legislative Days	May 20, 2014	Sacramento
General Manager Leadership Summit	Olympic Valley	June 22, 2014

GOLDEN STATE RISK MANAGEMENT ASSOCIATION (GSRMA)

No Information Currently Available on Upcoming Conferences.

SPECIAL DISTRICT AND LOCAL GOVERNMENT INSTITUTE (SDI)

No Information Currently Available on Upcoming Conferences.

ASSOCIATION OF CALIFORNIA WATER AGENCIES (ACWA)

2013 Fall Conference	Dec. 3 – 6, 2013	Los Angeles
2014 Spring Conference	May 6 – 9, 2014	Monterey

WATEREUSE ASSOCIATION

2014 WaterReuse Annual Conference	March 16-18, 2014	Newport Beach
-----------------------------------	-------------------	---------------

AMERICAN WATER WORKS ASSOCIATION (AWWA)

No Information Currently Available on Upcoming Conferences.

ISC WEST

No Information Currently Available on Upcoming Conferences.

CALIFORNIA RURAL WATER ASSOCIATION

No Information Currently Available on Upcoming Conferences.